



# THE PRINCIPIA

OR

THE FIRST PRINCIPLES OF NATURAL THINGS

TO WHICH ARE ADDED

## THE MINOR PRINCIPIA

AND SUMMARY OF THE PRINCIPIA

BY

EMANUEL SWEDENBORG

TRANSLATED FROM THE LATIN BY

JAMES R. RENDELL, B.A., and

ISAIAH TANSLEY, B.A.

WITH AN INTRODUCTION BY

ISAIAH TANSLEY, B.A.

AND A FOREWORD BY

PROFESSOR SIR WILLIAM F. BARRETT, F.R.S.

VOLUME I.

THE SWEDENBORG SOCIETY"

(inst it ut ed 1810)

1 BLOOMSBURY STREET, LONDON

1912

Q 141  
S 83  
v. 1

## PREWORD.

BY PROFESSOR SIR W. F. BARRETT, F.R.S.

Swedenborg the seer has largely obscured the fame of Swedenborg the savant. And yet two-thirds of his life were devoted to the service of science and the publication of numerous works, ranging over every department of natural knowledge. The neglect of Swedenborg's scientific writings is now being removed by the publication, under the able editorial supervision of Mr A. H. Stf^h, of Swedenborg's chief contributions to science, with Introductions written by eminent living savants. The sumptuous Latin edition of Swedenborg's *Principia*, issued under the auspices of the Swedish Royal Academy of Sciences, is prefaced by an Introduction from the pen of that distinguished man Professor Svante Arrhenius, to whom in 1903 was awarded the Nobel prize for chemical physics.

The present admirable English translation of the *Principia* we owe to the arduous and loving labour of Mr J. R. Rendell and Mr I. Tansley. The Introduction, written by the latter, was carefully read in proof both by myself and my friend Professor Silvanus P. Thompson, D.Sc., F.R.S., and I wish to acknowledge the courtesy with which the author adopted most of the numerous suggestions and criticisms we made; though the responsibility for the opinions expressed rests, of course, solely with the author.

Those who may read this translation of the *Principia* must remember that Swedenborg lived at a time when many of the now recognized branches of science had no existence, and the whole of experimental science was then an almost untrodden field. Swedenborg's *Principia*, with its archaic expressions and

obsolete forms of thought, its deductive and often erroneous reasoning, marks the transition from the old to the new. Swedenborg, though profoundly influenced by the then new school of Cartesian philosophy, which liberated the mind from the fetters imposed by <sup>a</sup> theologians, was nevertheless in many respects in advance of Descartes. This is strikingly shown in his adumbration of the nebular hypothesis which Laplace gave to the world a century later.

As I have said elsewhere <sup>1</sup> Descartes' philosophy, moreover, led to dualism—to an unbridgeable gulf between mind and matter, between Nature and Spirit, between the finite and the Infinite. Swedenborg saw this, as Leibnitz did fifty years earlier. Leibnitz derived all matter from infinitely minute points or                    each of which mirrored a phase of the universe, of the mind of God, between whom and the sum of created *monads*, which-made up nature, Leibnitz held there existed a pre-established harmony.

In some respects Swedenborg's conception of the physical universe resembles that of Leibnitz, whose writings he had studied, though he did not adopt the theory of pre-established harmony. But Swedenborg's view of the origin of matter though overlaid with complexities and fallacious ideas, is more like that to which science is tending at the present day. He conceived all matter as ultimately derived from what he terms "natural points"—which are, as it were, intermediate between the finite and the infinite. From the varied aggregation and motion of these points and their derivatives, he believed the physical universe was built up according to mechanical and geometrical laws. In his *Principia* he points out how the rapid motion of a minute corpuscle can generate a line, and the line an area, and the area a solid, and he goes on to say "a corpuscle thus moving can represent by its celerity and direction something which previously had no existence, and which is quite different from the corpuscle itself: and it is every way a figure, so far as our senses are concerned, although

<sup>1</sup> *Contemporary Review*, July 1912.

it is merely motion which produces the effect, or by means of motion form is fixed.”

In the physical point Swedenborg, like Leibnitz, asserts that all finite things are latent; the macrocosm is hidden in the microcosm. In fact, some years later in his *Arcana Ccelestia* he says : “ The Deity is in each single thing, and this even to such an extent that there is in it a representation of the Eternal and Infinite. From this influx arises effort, from effort force, and from force the effect.” This may come to be the orthodox view of science—for nature is the unfolding and indwelling of the inscrutable creative thought of God.

Swedenborg, in fact, considers the origin of matter to be infinitely minute *centres of force* which fill all space, and thus he approaches the views advanced some thirty years later by the Italian philosopher Boscovich. The great name of Faraday is associated with much the same opinion, for he remarks : “ Matter must fill all space, or at least all space to which gravitation extends, for gravitation is a property of matter dependent on a certain force, and it is this force which constitutes matter.” Science at the present day is tending to the same view, for the once universal belief in eternal immutable atoms, scattered in various states of aggregation through empty space, has been replaced by congeries of infinitely minute swiftly moving electrons; which appear again to be reducible to physical points, or centres of electric force filling all space, from the motion of which the fundamental properties of matter may eventually be deduced.

Mr F. W. Very remarks in his able paper, given in Appendix A, that Swedenborg conceived of the existence of a *vortex-atom*, which we have been accustomed to associate with modern ideas; but as Mr Very points out, “ while the first conception of elementary particles, formed by vortical motion of a sort, is attributable to Swedenborg, he has failed to hit upon the most probable form of this motion, as far as we are able to judge from present information.”

The first part of the *Principia*, with its elaborate discussion of the author's theory of the sub-division and modes of motion of material entities, and the strange terms he employs—Finites, Actives, and Elementaries—together with the series of Elements he derives from his fivefold series of finites and actives—the first or Universal Element, the second or Magnetic Element, the third or Ethereal Element and the fourth or Aerial Element—all this will repel, or excite a smile, in the scientific reader. Swedenborg himself appeared to realize this as seen in the first paragraph of the Preface to his work. • But in spite of much that we may dismiss in the light of modern knowledge, there runs throughout the whole work not only the true scientific spirit of an earnest seeker after truth, but a conception of the constitution of matter and of the structure of the universe, which may be regarded, as Mr Very remarks, “ as a first daring venture into the unknown and as the pointing out of a new road which is now being travelled in chemistry and physics with increasing surety that the goal is in sight.”

Swedenborg unfortunately does not appear to have studied Bacon's *Novum Organon*, published more than a century before he wrote his *Principia*; had he done so, and freed his mind from the errors of the Aristotelian and deductive philosophy which fettered scientific inquiry in his day, there can be little doubt that his learning and industry would have given him a high place in the history of science. As it is, his name does not even appear in the admirable chronology of physical and mathematical science compiled by Baden Powell in his *History of Natural Philosophy*.

The error which led ancient philosophers to argue that the circle is the most perfect of figures, that the heavenly bodies are perfect, and therefore their movements must all be performed in exact circles and with uniform motions, we find vitiating Swedenborg's reasonings. Even when the observation of the motions of the planets demonstrated that their orbits were not circular, instead of doubting the principle, as Sir John

Herschel remarks, “ they saw no better way of getting out of the difficulty than by having recourse to endless combinations of circular motions to preserve their ideal of perfection.” In like manner we find Swedenborg saying in his *Principia*, vol. i. p. 115, that from *a priori* principles the figure of the motion of the simple will be admitted to be absolutely perfect, “ and the only figure which has this degree of perfection is the circular ; and if the figure of motion is conceived as being in space then no other can be conceived than the absolutely perfect spiral.” Hence he becomes almost obsessed with the idea of spiral motion. This is well discussed by Mr Very in Appendix A, who, in reference to Swedenborg’s *Cosmology*, remarks on p. 626, that “it is evident that Swedenborg is still following Descartes, and though improving on the latter’s corpuscular theories, Swedenborg has failed to grasp the supreme significance of Kepler’s first law. The ellipticity of the planetary orbits, with the sun at one focus, instead of at the centre, was the great fact of nature which overthrew the Cartesian doctrine,” and with it much of Swedenborg’s reasoning.

Nevertheless, Swedenborg does accept Kepler’s first law, *i.e.*, that the orbit of a planet is an ellipse of which the sun is in one focus, for when speaking of “ magnetic spheres,” he says: “ This is observable in the large vortex of the sun, where the planets describe ellipses round their centre or sun, in one focus of which the sun is situated.” — *Principia*, vol. i. p. 256.

The second part of the *Principia* deals with magnetism, and is chiefly occupied with a transcript of Muschenbroek’s experiments on magnetism. Whilst we may dismiss Swedenborg’s idea of a magnetic element and magnetic spheres, we find a remarkable prevision of the molecular structure of a magnet. “ Magnetism,” Swedenborg remarks, “ consists only in the regular arrangement of the minutest parts of the magnet:—

“ Indeed, what proof could be plainer than the one derived from iron filings sprinkled round a magnet, which in a continuous line follow the

course of the magnetism and dispose themselves into the same situation and path as the smallest parts of the iron ; and if we could see the latter with the help of lenses or with the naked eye, they would be seen to be arranged in a similar manner. In filings, therefore, we see the effigy of the parts in the iron which are brought into a regular order at the will of the magnet. If we could artificially combine steel dust into a solid mass and move the magnet over it, we should have ocular proof that every atom took up that position, which the smallest parts of the iron assume when rubbed ; that is to say, a regular arrangement. If this arrangement of the parts of the iron be disturbed either by too frequent bendings or by too hard blows, or by fire, then the iron immediately divests itself of its magnetism and assumes its original character."

All this might have been written by a student of the present day and is perfectly correct.

In chapter i. of the second part of the *Principia* Swedenborg admirably depicts the molecular arrangement of iron before and after magnetization, and also the lines of force around a magnet, or between magnets with similar or opposite poles juxtaposed. These numerous drawings show that he must carefully have studied the curves formed by fine iron filings sprinkled on a surface placed above the magnets. Though electro-magnetism was unknown until long after, his representation of right and left handed spires round a magnet look very like electro-magnetic solenoids.

Again, Swedenborg regarded heat and also light as produced by the " tremulation " of the minute parts of bodies and he adopted the undulatory theory of light in a continuous medium—the ether. This was the theory propounded by Huygens a little prior to Swedenborg, although the authority of Newton and his corpuscular hypothesis long delayed the general acceptance of the wave theory of the propagation of light.

It is not necessary to dwell on Swedenborg's system of Cosmology contained in the third part of his *Principia*, as this has been discussed and some of Swedenborg's remarkable anticipations of modern views set forth by Prof. Arrhenius in his introduction to the *Principia*, already referred to. In part II. Swedenborg gives a painstaking calculation and forecast



of the magnetic declination in Paris:—that is the angle enclosed between the geographical and magnetic meridian—for 200 years in advance of his time. Unfortunately The“ data upon which he based his calculations were then too few to enable such a forecast to be made, and accordingly, instead of the declination being  $36^{\circ}$  east in the present year, as Swedenborg calculates, it is less than half this to the west. Swedenborg was, however, correct in his assumption of the rotation of the N. magnetic pole around the N. geographical pole, but the rate of this secular change was incorrectly calculated, although his theory and observation agreed up to the time when he wrote.

One of the most interesting and striking chapters in the *Principia* is that entitled “The Diversity of Worlds,” vol. ii. p. 162 *et seq.* Here it will be seen how completely Swedenborg has emancipated himself from the narrow and intolerant theology of his own day (and long after) that regarded the Bible as the only recognized authority on science, and denounced as heretical any theory of the cosmos which did not agree with the literal interpretation of the Biblical story of creation. So far from conforming to any restricted and geocentric conception of the universe, he revels in the thought of the immensity and the mystery of creation, and exclaims, “How many myriads of heavens, therefore, may there not be, how many myriads of world systems.” Worlds, indeed, may wax and wane, “the coming into existence of infant heavens and earths is possible, when others are beginning to become old and fall into decay.” Then he contemplates the vast succession of changes through which the world has passed before arriving at its present state; nevertheless, he says, “in each elementary particle we see the whole process of its creation evident and manifest, resembling the world, both as it exists and subsists.” The law of continuity, he insists, runs throughout the universe, whether in the molecules of matter or in stellar systems, whether in the present life or in the life beyond the grave.

But although the universe is based upon a common plan, yet he remarks, "how great is the extent of our ignorance. Everyone measures his wisdom by his understanding of those things with which he is acquainted. The limit of his own information he considers to be the limit of all that is attainable, for he is ignorant of all else. The bounds of his knowledge are the bounds of his wisdom." But, he continues, there is no limit to the extent of our ignorance, "There is not a particle in our globe with the thousandth part of whose nature we are acquainted. In the mineral, vegetable, and animal kingdoms, what we know is nothing compared to what we have yet to learn; for the soul [the intellect] knows nothing of those things which the senses do not perceive." And yet the spirit of arrogance and self-sufficiency is not unknown among scientific men of the present day.

In his Conclusion to the *Principia*, p. 289 *et seq.*, Swedenborg gives a summary of his philosophy of nature, and he adds noble words that were characteristic of his whole life, viz., that it was a matter of indifference to him whether he won praise or censure, for he desired neither renown nor popularity, but was actuated solely by the love of truth. He has no wish, he tells us, to oppose those who impugn his statements, but if he should perchance win the assent or approbation of others he will receive it as an indication that he has pursued the truth. The future, he adds, will show whether his system of philosophy is in agreement with the phenomena of nature and, if so, assent in due time will follow.

This is the true spirit of science, and illustrates what Sir John Herschel so well said, that "humility of pretension, no less than confidence of hope, is what best becomes the character of the true philosopher."

## INTRODUCTION.<sup>1</sup>

Emanuel Swedenborg, the author of the present work, was born at Stockholm, on the 29th of January 1688, his father being Bishop of Skara, of West Gothland. Swedenborg was little, if at all, influenced by the narrow dogmatic theology of the period; the bent of his mind was scientific ; and very early in his life he gave evidences of quite an unusual love of experiment and observation in the natural and physical sciences ; a fact clearly shown in his correspondence,, dating from 1709 to 1726. The fact that he invented a new form of air pump, which Professor Silvanus P. Thompson says was the first mercurial air pump, and an effective instrument, gave suggestions for a submarine, and drew a rough plan of a flying machine, showed the activity of his mind, and promised well for the future work of this restless young genius.

On the conclusion of his University career at Upsala he travelled abroad. In England he met with Flamsteed, the distinguished astronomer, made the acquaintance of Halley, and picked up all the knowledge of men and things that he could. Although there is no evidence that he ever met Newton, yet he was a diligent and appreciative student of his *Principia*. He edited at Upsala, 1716 and 1717, the *Daedalus Hyperboreus*<sup>2</sup> the earliest scientific magazine published in Sweden. As assessor of the College of Mines he made an extensive collection of observations on metals and smelting

<sup>1</sup> The writer has to thank Professor Sir W. F. Barrett, F.R.S., and Professor Silvanus P. Thompson, D.Sc., F.R.S., for their kindness in reading the proofs of this Introduction and for their valuable suggestions and criticisms.

<sup>2</sup> Recently reproduced in facsimile by Upsala University.

processes, during a prolonged visit to Germany, and published the results of his observations at Dresden and Leipsic (1734) in three folio volumes, entitled, *Opera Philosophica et Mineralia*, which are elaborately and profusely illustrated; the present work being the first of these three volumes. This costly publication was printed at the expense of the Duke of Brunswick-Liineburg. Although geology as a distinct science had not taken shape in Swedenborg's day, yet he worked in this field with considerable industry and care, and wrote much on the subject. Professor Nathorst remarks "that the contributions of Swedenborg and Linnaeus in the geological field have been less valued than they deserve is without doubt due to this, that their fame in other fields was so great, that what they produced in geology in comparison therewith seems relatively unimportant, and has therefore been much overlooked."<sup>1</sup> His correspondence shows how closely and widely he had investigated and taken note of the natural formation and structure of Sweden, his native country.

But there was a speculative tendency in his nature which instinctively led him to enter another field of thought, whither he was probably urged by an important controversy which agitated his own University. The celebrated Descartes was invited to Sweden in the early months of 1649 by Queen Christina. The University was then under the sway of the prevalent theology and scholastic philosophy; these were regularly taught, and without question. Aristotle's writings formed the text-book of the schools, always studied with the direct intent of confirming the dogmatic and prejudiced teachings of the church. But the coming of René Descartes introduced a contentious element; for the priests in session at Stockholm complained that Cartesianism had entered the University. "But the discussion which arose," says a writer, "was not so much concerning the limitations to be imposed upon the leaders of the dawning natural sciences,

<sup>1</sup> See Emanuel Swedenborg, *Geologica et Epistolae*. Introduction by Prof. Alfred G. Nathorst, Superintendent, State Museum for Fossil Plants, Stockholm.

who, basing themselves upon experiments and the principles of Descartes, were demonstrating the laws of nature from its own phenomena, thus destroying the structures of Aristotelian Scholasticism not only in the field of the natural sciences, but even in that of theology itself, thus endangering religion.”<sup>1</sup>

This controversy was at its height about the time of Swedenborg's birth; but Cartesianism triumphed over the ecclesiastical forces ranged against it, one of the results being greater freedom of thought, and the consequent awakening of a new scientific spirit. In 1\*710 the first scientific society in Sweden was established, which included Swedenborg among its members. Into this clearer and scientific atmosphere, then, this remarkable genius was born. But great as was the influence of Cartesianism, Swedenborg's mind was not one to be seriously affected by opinion; he was an original thinker. It is certain, from his early correspondence that he was particularly interested in practical astronomy; and there is evidence that his mind soon began to dwell on cosmological questions. There are no details clearly indicating how his speculations came to assume their final form as contained in *The Principia*] but it is certain that he was acquainted with the cosmology of Descartes and the philosophy of Leibnitz; beyond that there is little to guide us in our investigations. That he had made extensive' preparation before finally publishing his thoughts is clear from the existence in MS. of an earlier work,<sup>2</sup> in which he entered into a careful and elaborate study of the problems of which he attempted an ultimate solution in the later treatise.

And we would remark here that all the evidence goes to show that Swedenborg possessed a remarkable power of generalization, and that with this there was allied an active scientific imagination, an essential attribute of an investigator, as Professor Tyndall long ago felicitously remarked. In the

<sup>1</sup> See *The Cartesian Controversy at Upsala, 1663-1689*, by Alfred H. Stroh, M.A.

<sup>2</sup> See *The Minor Principia* at the end of vol. ii. of the present work.

exercise of this faculty in cosmological speculation he endeavoured to work out a theory of origins both daring and unique. His reasoning proceeds along lines never before attempted, we believe, by any writer, his main purpose being to propound a theory of the evolution of our planetary system. The details of the arguments which he uses in leading up to this ultimate issue are often involved in considerable obscurity ; but while mathematical analysis may find many weak links in his chain of reasoning, showing that he is sometimes lost in the maze of his own theory, yet it will be shown hereafter that some of his anticipations of modern ideas are, at least, remarkable. But no theory is ever given to the world so complete as to be invulnerable. Darwin's great generalizations have presented many weak points ; and have been considerably modified by subsequent investigations. The theory of matter which held the scientific field up till recently, and appeared to be supported by all the resources of chemical and mathematical analysis, has been relegated to the domain of scientific history, while the theory of an all-pervading ether, involves almost insuperable difficulties in framing a conception of its nature. But, nevertheless, it still holds that great generalizations form epochs in the advance of scientific ideas. As a writer says, " Science lives on facts, but it has always been great generalizations which have given them birth." <sup>1</sup>

In the case of Swedenborg's theory, the facts which he had to work upon were necessarily few. Exact experimental procedure was little known in his day ; but a mere collection of facts without the genius for seeing their connection could never advance science in any way. It is men like Kepler, Newton and Faraday, with little material to their hands, but with the power to see the correlation of phenomena, who have given great and permanent generalizations to the world.

Several instances might be adduced to prove that Swedenborg had the scientific spirit for interpreting facts brought together by himself and other investigators. It

<sup>1</sup> Dr Gustave Le Bon, *The Evolution of Matter*, p. 318.

may be sufficient to refer to his theory of the functions of the brain, and his explanation of the functions of the ductless glands. Professor Neuburger,<sup>1</sup> in a paper dealing with Swedenborg and Modern Physiologists, says : “ It would lead me too far were I to show in detail how early Swedenborg in these questions approached the present ideas, and how advancing science is beginning just now to verify many of his theses in a surprising manner.” “ He was the first,” he continues, “ to assign definitively the higher psychical functions and the perception of the senses to the grey substance of the brain; he taught in harmony with modern science that the various motor functions have each their special localization in the cortex cerebri, and so forth.”<sup>2</sup> And D. Goyder, M.D., of the Bradford Infirmary, in a *paper* read before the International Swedenborg Congress, on the\* Ductless Glands, says : “ Swedenborg by his wonderful deductions anticipated many of the pre-eminent offices of these ductless glands which the medical profession of to-day are only beginning to discover.”

F\* Our purpose in calling attention to these points is to prepare the reader to follow Swedenborg when he takes him into a region of thought which seems to have been peculiarly his own. His speculations lead him to consider the question of origins. Whatever may have been the influence of Cartesianism upon Swedenborg’s thought he certainly goes beyond Descartes, and, in a measure, appears to be moving in the atmosphere of ancient philosophers.<sup>3</sup> For this question of the origin of things, the “ whence ? ” and “ why ? ” engaged the attention and absorbed the thought of early Greek thinkers. These men endeavoured to solve the problem of the mystery of matter. The earliest Greek philosopher of whom we have record who tried to read the inner history of phenomena was Thales (640-550 B.C.). He

<sup>1</sup> Professor of the History of Medicine, Vienna University.

<sup>2</sup> See *The Transactions of the International Swedenborg Congress*, pp. 123,124.

<sup>3</sup> See his *Economy of the Animal Kingdom*, vol. ii. n. 591, 605.

saw in water the origin of the life and change manifested in the visible world. The Pythagoreans thought that the explanation of the world must be based, not on qualitative, but quantitative grounds. The Eleatics, who had among them some very keen reasoners, were practically monists; they endeavoured “to reduce the manifold of existence to a simple ultimate principle.”<sup>1</sup> They sought an ultimate ground of origins. Melissus of Samos (*circa* 400 B.c.) reasoned in a way which shows very clearly how keenly men were interesting themselves in the eternal questions “whence ?” and “why ?” “If anything is,” he says, “then it has either become or is eternal. In the former case, it must have arisen either from being or from non-being. But nothing can come from non-being ; and being cannot have arisen from being, for then there must have been being, before being came to be. Hence being did not become, it hence also is eternal.”<sup>2</sup> Anaxagoras (b. 500 B.c.) saw that to postulate an eternal ground of things, *απξf<sub>h</sub>* as Anaximander did, without a principle of explanation, why, out of this *αp%oj*, the phenomena of the world arose, was philosophically unsatisfactory. He, therefore, assumed a spiritual force which he called *voug*, which set up movement in the inert mass of things in the form of a vortex. This was a distinct advance ; and the notion of a vortex or whirling movement was destined to be perpetuated long after the time of its originator. It is interesting to observe here the genesis of the idea of motion as accounting for change and becoming, which has been so elaborated in the course and process of thinking that it now forms the basis of modern molecular physics.

Democritus the atomist carried the method of interpreting the universe farther than Anaxagoras, and introduced the principle of differentiation. He considered primal matter to consist of atoms. Mendeldef puts his position as follows : “The atoms, which are infinite in number and form, constitute

<sup>1</sup> Schwegler, *History of Philosophy*, p. 15.

<sup>2</sup> Ueberweg, *History of Philosophy*, vol. i. p. 59.



the visible universe by their motion, impact, and consequent revolving motion. The variety of objects depends only on a difference in the number, form, and order of the atoms of which they are formed, and not upon a qualitative difference of their atoms.”<sup>1</sup> These remarkable propositions were purely intuitive conceptions; experimental science being unknown in the fifth century B.c. when Democritus wrote ; but they are an extraordinary anticipation of the general principles on which molecular physics was based, until recently. No single philosopher has ever enunciated a principle so fundamental, and so far reaching in its effect upon the thinking consideration of things. It was left to Lucretius, who lived in the days of Cicero and Caesar, to elaborate, amplify and extend the principles of Democritus. He saw that matter was in constant movement. “ He actually anticipated,” says a writer, “ the modern scientific and philosophic theory which reduces all material phenomena to motion, or to mass and motion.”<sup>2</sup> We have then, so far, two fundamental points established by these great thinkers, matter and motion. Practically no advance beyond this position had been made except in the elaboration of these concepts by the resources of modern experimental science and mathematics, until the coming of what has been termed the “ new knowledge,” which, while retaining the idea of motion, has reconstructed the concept of matter.

We have gone at some length into this subject because it seems necessary to understand this early phase of intellectual development and its bearing upon modern thought; for practically the position is still this, that two things are definitely postulated—a primal matter, and motion or energy intimately associated with it.

We would, then, in this connection, remark that while Swedenborg was undoubtedly acquainted with Cartesian cosmological physics, he was, doubtless, perfectly familiar with

<sup>1</sup> Quoted by Ronald Campbell Macfie, M. A., in *Science, Matter and Immortality*, p. 13.

<sup>2</sup> *Ibid.* p. 24.

the views of the Greek philosophers and the atomic theories of Lucretius.<sup>1</sup> In Descartes he would find ancient ground worked over and some new conceptions imported into the same. But what Descartes meant by matter it is not easy to see. Ueberweg says that “ he attributes to matter nothing but extension and modes of extension, no internal states, no forces \ pressure and impulsion must suffice for the explanation of all material phenomena.”<sup>2</sup> But the following words seem to take us no farther in thought than the Greek notion of a *male/ria prima*. “ Let us suppose, then, if you will,” says Descartes, “ that God divided at the beginning all the matter of which he has formed the visible world into parts as equal as possible.”<sup>3</sup> He further supposed that these material particles knocked their corners off by striking one against another, so that they became perfectly round and transparent ; these were called\* “ particles of the second kind.” Out of the knocked-off corners there was formed a fine dust of “ particles of the first kind,” which formed the fixed stars, and so on. Professor Arrhenius,<sup>4</sup> who condenses Descartes’ views as above, and says that he without doubt exercised the greatest influence upon Swedenborg’s views, seems to us to be quite mistaken when he remarks that in Swedenborg’s work no other change is made in these conditions than that the number of particles is increased and an attempt made to derive all of them from the mathematical point.<sup>5</sup> However, we are not sorry that Professor Arrhenius has stated his view of Descartes’ theory, as it will enable the reader to see that, whatever the influence of this philosopher upon Swedenborg’s thought, he nevertheless cut out a course for himself.

But even if this “ matter ” is to be taken as given in conception, the question of origins still remains where it was. Having

<sup>1</sup> See *The Economy of the Animal Kingdom*, vol. ii. n. 605.

<sup>2</sup> *History of Philosophy*, vol. ii. p. 52. J. B. Stallo, *Concepts of Modern Physics*, p. 228.

<sup>3</sup> *Principles of Philosophy*, part iii. p. 143.

<sup>4</sup> Principal of the Nobel Institute for Physical Chemistry, Stockholm.

<sup>5</sup> See Latin reprints, vii. *Cosmologica*, Introduction by Svante Arrhenius, p. xxv.

practically taken over one principle of ancient philosophy—primal matter, modified in idea by its association with the Infinite, Descartes also took over the complementary idea of motion, and enunciates the fundamental physical principle that “all variations of matter, or all diversity of its forms, depend on motion.”<sup>1</sup> But in this he did not advance much beyond Lucretius. Subsequent thinkers also, Thomas Hobbes, the philosopher, Leibnitz, Huygens, and Newton, all argued for a mechanical interpretation of the universe; on the principle of movement alone could nature be explained. And the same principle characterizes the latest phase of modern molecular physics. Swedenborg, then, was quite familiar with this doctrine, made it the basis of his own theory of origins, and worked it out minutely in application to his own system. He found the principle stated by Musschenbroek, a Dutch scientist, who was the first to publish a comprehensive treatise on physics, and who said, “no change is induced in bodies whose cause is not motion.” It may be interesting to quote the exact words of this writer in order to show, by subsequent comparison, that Swedenborg must have carefully studied this work. His words are : “Nulla autem corporibus inducitur mutatio, cujus causa non fuerit motus, sive excitatus, sive minutus, aut suffocatus; omne enim incrementum vel decrementum, generatio, corruptio, vel qualis cumque alteratio, quae in corporibus contingit, a motu pendet.”<sup>2</sup>

A quotation from Swedenborg will show that his view of the fundamental importance of motion was practically identical with that of Musschenbroek. “Rational philosophy,” he says, “will not admit that anything can be, or exist without a mode ; and since a mode in limited, finite, or in physical things consists solely in the variation of limits, it therefore follows that nothing can exist without motion. Whatever is

<sup>1</sup> Descartes, *Principles of Philosophy*, ii. 23.

<sup>2</sup> P. v. Musschenbroek, *Introd. ad Philos. naturalem*, vol. i. cap. 1, § 18 (published 1726). See note on Musschenbroek in Appendix B.

devoid of motion, remains such as it is ; whatever is at rest, produces nothing. If anything is to be produced, it must be produced by a mode or by motion ; if anything is to be changed, it must be changed by a mode or by motion ; whatever comes to pass does so by a mode that is, in physics, by motion. Without motion or change of place, or more generally, without a change of state, no new existence, no product, no coming to pass can be conceived, that is, nothing is capable of existence or change, except by motion.”<sup>1</sup>

Swedenborg, then, worked over the idea of motion handed down by his predecessors and applied it, as we shall see, in his own way to his own theory; indeed, the quotation just given might almost stand as a setting forth of the fundamental position of modern, physics. But while adopting this principle, as he was bound to do, he took up an entirely new attitude in regard to the question of a *materia primci*, the undifferentiated, from which has come by various processes of division and composition the complex material of nature.

To solve the mystery of the primal substance has always been a fascinating and attractive study. And so the efforts of chemists are directed towards the simplification of conceptions and the tracking down of what seems highly complex to some simple non-complex material from which all things are compounded. Mr. W. C. D. Whetham, in a historical reference to the evolution of matter, says, “Nevertheless, throughout these years, on the whole so unfavourable to its existence, there persisted the idea of a common origin of the distinct kinds of matter known to chemists. Indeed, this idea of unity in substance in nature seems to accord with some innate desire or intimate structure of the human mind.” And he continues : “As Mr Arthur Balfour well puts it, ‘there is no *a priori* reason that I know of for expecting that the material world should be a modification of a single medium, rather than a composite structure built out of sixty or seventy elementary sub-

<sup>1</sup> *The Principia*, vol. i. p. 55.

stances eternal and eternally different. Why, then, should we feel content with the first hypothesis and not with the second? Yet so it is. Men of science have always been restive under the multiplication of entities. They have eagerly watched for any sign that the different chemical elements own a common origin, and are all compounded out of some primordial substance.”<sup>1</sup> Scientific men acting on the belief expressed in the above words have been endeavouring to prove by research and experiment what they believed *a priori* to be the case.

Now Swedenborg, anticipating Wolff in his work, *Cosmologia G-eneralis*, had a clear perception of the question of a *materia prima*, although he was not, of course, able to prove its existence, or even approximately do so, by experiment. But philosophical insight may have a prevision of results that are afterwards substantiated. The following words from *The Economy of the Animal Kingdom*, a work published later than *The Principia*, shows, at least, a remarkable forecast of what is now in course of being fully established by experimental science. “The primary substance of the world,” he says, “is the only one which does not come within the understanding as differentiated. From this, as from the first determining substance, or the *substantia prima*, proceed all the rest as series or discretions. Thus, whithersoever we turn our attention, all things we become acquainted with are only discretions originating in the primary substance.”<sup>2</sup> Consequently this *substantia prima*, he says, “This primary substance of the mundane system is the most universal of substances, because the only one in compound substances.”<sup>3</sup> We shall have occasion to refer to this proposition later in following out the development of his theory.

Up to recent times the conception of Democritus, although given to the world many centuries ago, were

<sup>1</sup> Paper on the Evolution of Matter, by W. C. D. Whetham, M.A., F.R.S., in *Darwin and Modern Science*, p. 566. Cambridge University Press.

<sup>2</sup> Vol. ii. p. 8.

<sup>3</sup> *Ibid.* p. 25.

current in the scientific world; although the main idea has been, of course, subject to variation in the course of philosophic speculation. Descartes, although introducing certain modifications, held that "the matter which exists in the world is everywhere one and the same."<sup>1</sup> Newton does not appear to have held precisely this view, but the following words show that he did not attempt to go behind an original substance. "It seems probable," he says, "that God in the beginning formed matter in solid, massy, hard, impenetrable movable particles of such sizes and figures, and with such other properties and in such proportion to space as most conduced to the end for which he formed them."<sup>2</sup> Herbert Spencer held the view that properties of bodies result from the variety in arrangement of an original discreted material. "The properties of the different elements," he says, "result from differences of arrangement by the compounding and recompounding of ultimate homogeneous units."<sup>3</sup> These, out of numerous opinions, sufficiently prove our contention expressed above, that up to the time of those writers little change had taken place since the views of Democritus were given to the world. But the mystery of the origin of matter still remains where it was. That there is a desire to fathom this mystery is clear to anyone acquainted with the strivings of philosophy to get behind matter. Even the title of an article indicates the trend of thought in this direction, such as "The Evolution of Matter," by Mr. W. C. D. Whetham, M.A., F.R.S., in the series of monographs forming the Cambridge centenary volume, *Darwin and Modern Science*. For the human mind will not rest satisfied with effects ; it desires to find out causes. Seeing quite clearly that particular phenomena can be traced to some definite cause, the mind wants to know what is the cause of the collective whole. "If a cause is needed for a finite series," it feels that the cause is "equally needed for an infinite series."<sup>4</sup>

<sup>1</sup> "Materia itaque in toto universo una et eadem existit," Prin. Phil. ii. 23.

<sup>2</sup> *Opticks*, fourth ed., p. 375.

<sup>3</sup> *Contemporary Review*, June 1872.

<sup>4</sup> H. M. Gwatkin, M.A., *The Knowledge of God*, vol. i. p. 17.

The scientist may profess that he is not concerned with ultimate origins at all; but if he is endeavouring to trace the evolution of matter he is unmistakably trying to get behind the *materia, prima* to find out how it has come to be what it now is. Already there are evidences that the new spirit in science is leading men away from the old inconsistent and illogical materialism and inducing the best minds in the scientific world to seek for a more intelligent interpretation of the universe. Science and philosophy are not now so antagonistic as formerly. Philosophy makes use of the new material provided by science, and science is breathing a more philosophical atmosphere. Science, which is mainly concerned with the perceptual, enters into the domain of the conceptual when formulating and discussing its theories. This fact is too frequently overlooked by scientists. They may not be concerned about it; but they are logically involved in its toils. Professor Karl Pearson has dealt very cleverly with this point. "Ether," he says, "is a conception rather than a perception. Hertz' experiments, for example, do not seem to me to have specially demonstrated the perceptual existence of the ether, but to have immensely increased the validity of the scientific concept ' ether ' by showing that a wider range of perceptual experience may be described in terms of it than had hitherto been demonstrated by experiment." <sup>1</sup>

Into this conceptual region the reader of *The Principia* will find then that Swedenborg fearlessly takes him. But he will also find that he is by no means unmindful of the importance of the perceptual; for in the first chapter, writing on " The means leading to true philosophy," he regards experience, mathematics, and reasoning as of the first importance. And in developing his theory of the magnet he adduces a vast body of evidence from the experiments of Musschenbroek. Swedenborg here, however, enters a speculative region in which hypothesis could hardly be followed up

<sup>1</sup> *The Grammar of Science*, p. 214. Contemporary Science Series.

by experiment; but his hypothesis was to lead up to an issue, which we hope to show<sup>7</sup> later, has been confirmed by modern research. His initial purpose, as we have said, is to trace the evolution of matter, to get behind the *materia prima* and find how it originated. A daring philosophical attempt, indeed, but, on that account, the more worthy of commendation. His mode of procedure is to postulate a definite starting point without theological prejudice—the Infinite, the primary cause. “What can be more self-contradictory,” says a writer, “than the hypothesis of a chain of causes and effects, each link of which hangs on a preceding link, while yet the whole chain hangs on nothing. Reason, therefore, itself points us to the need of a first cause of the universe, who is at the same time a self-existing, necessary, Infinite Being.”<sup>1</sup> If the mind wishes to avoid the conception of an absolute origin it is landed in the dilemma of an eternal, self-existent, non-caused, *materia prima* from which the universe has been evolved. But this takes us into the region of the unknowable, cuts the ground from under many scientific theories, and would stifle all desire to pass beyond the domain of the perceptual into the region of the conceptual.

Swedenborg postulates the Infinite, not with any theological end in view, not influenced by dogmatic prejudice, but with the freedom of a philosopher seeking to establish certain principles, and endeavouring to reach a certain end. To quote his own words, “nothing that is finite can exist from itself, that is, without purpose and a cause. For there must also be a reason why it was United in this way, and in no other; or why it has reached this limit, and no other. In other words, nothing can exist without a cause save the Infinite . . . what is finite, therefore, takes its origin from what is infinite, as an effect from a cause, and as a thing limited from what is in itself unlimited, yet having the power to limit all other things.”<sup>2</sup> And this Infinite is

<sup>1</sup> Professor James Orr, *The Christian View of God*, p. 96.

<sup>2</sup> *The Principia*, vol. i. p. 51.



totally inclusive, and also the absolute and primary cause. "The Infinite itself is the cause and origin of the whole finite world and universe; this Infinite is a unity in which greater or less can have no existence, and in which there are simultaneously all things that ever can be."<sup>1</sup> The Infinite, then, instead of being absolute, apart from, and having no relation to the universe, is intimately related thereto. But the difficulty encountered is the representation of this relation, the formation of a concept which, at the same time, embraces the idea of transcendence and immanence ; for the Infinite relatively to the finite must be considered negatively and non-quantitatively, and as a higher order of being in which there are no limits or modes. The Infinite must be conceived as imposing quantitative conditions upon the finite, itself remaining eternally unconditioned. This conception is fundamental to Swedenborg's position, and he expresses himself as follows: "Everything finite acknowledges a certain mode, by which it is what it is and nothing else; a mode by which it is of such a form and no other; a mode by which it occupies such a space and no other. In a word all finite things are modified ; and therefore they acknowledge a mode prior to this modification, and according to which it takes place; they acknowledge also a time in which they are so modified. Hence nothing is at once what it can become except the Infinite. All finite things must necessarily undergo different states successively ; but not so the Infinite. And thus we perceive that all things except the Infinite have their modification, but that in the Infinite there is no such thing as development, simply because He is the first and the original cause of all modification."<sup>2</sup> Having stated this conception of the Infinite, Swedenborg has before him the problem of showing how the finite could arise from it, how matter subject to modification could originate from that which is negative in this regard. Although this would seem to be an insuperable problem, yet on

<sup>1</sup> *The Principia*, vol. ii. p. 151.

<sup>2</sup> *Ibid.* vol. i. p. 53.

the principle of relativity the finite implies the Infinite; the limited the unlimited; the conditioned the unconditioned. But what is the nexus ? How does the limited, the modifiable, arise from the non-limited and the unmodifiable ? We are confronted with a similar problem in the antithesis between thought and brain substance. How does a material impression on nerve substance become a mental picture which is capable at any moment of being represented, and yet has none of the qualities of matter ? Yet there must be a nexus between thought and matter, between the sequent and the antecedent. Thought corresponds so precisely in its active relation to matter that a connection must be inferred unless the undemonstrable monistic position be assumed again. Now if Swedenborg fails, as it must be confessed he does, to provide the material for the formation of a definite concept, yet he makes a bold attempt to account for the derivation of the finite from the Infinite in a way attempted by no other writer or philosopher. *Ab initio* the Infinite is absolute and non-relative, for as yet there is nothing to which it can come into relation. In it as the antecedent all sequents are *in potentia*. “ The Infinite,” he says, “ is the cause and origin of the whole finite world and universe; this Infinite is a unity in which there are simultaneously all things that ever can be.”<sup>1</sup> Either this condition, certainly profoundly difficult, must be granted or the quest must be abandoned. But he did not abandon it; he follows up sequents to the Infinite itself and finds in it the origin of motion, an internal state or effort towards motion. “ When we lay down the position,” he says, “ that the first motion exists in the Infinite, it is absolutely necessary that such motion should be considered as pure and total.”<sup>2</sup> Absolute motion then is the primary antecedent of all sequents. Whatever opinions may be held on the moot question of origins, there can be no doubt in the minds of those acquainted with modern results that all phenomena are

<sup>1</sup> *The Principia*, vol. ii. p. 151.

<sup>2</sup> *Ibid.* vol. i. p. 61.

regarded as due to motion. And to such refinement has thought upon the relation of motion to phenomena been carried, that a concept of motion in relation to the constitution of matter implies enormous velocities, and highly complex movements. The tendency of modern physics, as long ago stated by Professor Huxley, is to reduce, all scientific problems to the motions of ultimate particles of matter, and if all phenomena could be mathematically expressed in terms of motion we should have a complete interpretation of the universe. Swedenborg practically says that motion is a synonym for nature. Keeping to his position of Infinite origins he says, " Nature is only a word which expresses all the motive forces proceeding from the first motion of the Infinite till the world was completed." <sup>1</sup>

In the primary, infinite, absolute motion then all things were *in potentia*, as, analogously, a universe is potentially in a nebula. Following out his postulate Swedenborg endeavours to explain what is to be understood by absolute motion. " How then," he asks, " are we to conceive of this purity and totality in motion ? Certainly in no other way, if geometrically and rationally understood, than as an internal state or effort toward motion. For if in the whole motion there are no steps in space, no moments in time, and thus no velocity, and if again there is nothing substantial as before observed, what else, according to human notions or idea, can result thence but effort. When we understand space simply as it is, and consider motion as pure and apart from time, in such case the motion must be instantaneously present in every part of its own space : and thus it will be like effort itself: for in effort not only is motion everywhere present, but also its force and direction."<sup>2</sup> The reference which the author makes to effort makes his definition of absolute motion equivalent to state. Effort, as a matter of our experience, implies persistent motion *in potentia*. In effort we have no conception of velocity, but

<sup>1</sup> *The Principia*. The Means leading to true Philosophy.

<sup>2</sup> *The Principia*, vol. i. p. 63.

that of a state capable of becoming kinetic in some self-representative, self-realizing act. The concept of motion is commonly associated with velocity, or of passing from place to place; but potential motion as “state” is the source of all self-realization as seen in the countless things made by human hands. We are glad to find so distinguished a philosopher as Hermann Lotze taking a similar view. Discussing motion he says, “Still I feel that these doctrines [in regard to movement] are inadequate, as strongly as I am persuaded that they are correct; they leave in obscurity a particular point on which I will not pretend to see more clearly than others. It concerns that transition of *e*, from one inner state to another, which in acting on us produces for us the semblance of a motion in *e*. It must of course be conceived as going on at times when it does not act on us, or before it begins to act on us; and at those times it can be nothing but an *inner unspatial occurrence which has a capacity of appearing at some later time as motion in space* by means of that action upon us which it is for the moment without,” and again, “It is certainly my belief, though I will not attempt a more definite proof, that mental life would present instances of such a self-perpetuating process, which would correspond in their own way to the idea, extraordinary as it is though not foreign to mechanics, of a *state of motion*.”<sup>1</sup> This might be taken, we think, as a pretty fair expression of Swedenborg’s position in reference to absolute motion in the Infinite.

But our author’s conception seems to be still further enforced if we take effort as equivalent to will. For while it may be contended that the Infinite is unknowable as not being commensurate with anything finite, yet agreeing with Schopenhauer that in the universe there is “Will,” we are bound to admit that the finite will is analogous to the Infinite Will as an effort towards self-realization. But as the self-realization of finite will in act implies end or purpose, so it is legitimate to infer from the evidences furnished on every hand by science that

<sup>1</sup> Hermann Lotze, *System of Philosophy, Metaphysics*, n. 170. The italics are ours.

the Infinite Will would realize itself in end or purpose, in the generation of a universe, in which it would find itself realized, and self-reflected. It is true enough that the mechanical or necessitarian evolutionist pretends to see neither method nor purpose in the process by which we are assured an amoeba, through countless ages, developed into *homo sapiens*. But, assuming that this was the case, such process must have taken place along definite lines terminating in a definite organism. If this does not imply end or purpose, then language must have another meaning and the laws of logic must be a delusion. Either the universe in all its details is merely fortuitous, or a controlling, directive factor must be acknowledged to enter into the calculation. On this point Sir Oliver Lodge has the following : “ Take the origin of species by the persistence of favourable variations,” he says ; “ how is the appearance of these same favourable variations accounted for ? Except by artificial selection not at all. Given their appearance, their development by struggle and inheritance, and survival can be explained; but that they arose spontaneously, by random change without purpose, is an assertion which cannot be justified. Does anyone think that the skill of the beaver, the instinct of the bee, the genius of a man, arose by chance, and that its presence is accounted for by handing down and by survival ? What struggle for existence will explain the advent of Beethoven ? What pitiful necessity for earning a living as a dramatist will educe for us a Shakespeare ? These things are beyond science of the orthodox type : then let it be silent and deny nothing in the universe till it has at least made an honest effort to comprehend the whole.” <sup>1</sup> This is a rebuke which dogmatic scientists might take to heart; for if chance has no place in the cosmos then we must assume that there is a rational order in it, that it is a unity, that there is an adjustment of means to ends, that, on all the evidence, thought is behind phenomena and is indeed the necessary *prius* of all else, as put by the late Professor T. H. Green, of Oxford.

<sup>1</sup> *Man and the Universe*, p. 39.

Motion resulting in a universe and the subsequent cause of all its phenomena implies this *prius*, or we should be brought to the unthinkable position that all such motion is fortuitous, uncontrolled, and undirected. It is highly interesting to be able to quote Professor G. F. Fitzgerald, who very significantly uses words which completely support the above remarks. "What," he says, "is the inner aspect of motion? In the only places where we can hope to answer that question, in our brains, the internal aspect of motion is *thought*. Is it not reasonable to hold with the great and good Bishop Berkeley that thought underlies all motion." <sup>1</sup> We welcome these words because they state a principle *a priori*, based on no positive experimental evidence, and yet expressing an undoubted truth. We are glad to quote them, more especially because Professor Fitzgerald, in a report on Swedenborg's *Principia*, drawn up by request of the Swedenborg Society, condemns Swedenborg because he bases his system on *a priori* principles! As a matter of fact the words above quoted might be Swedenborg's. For "the internal aspect" of Infinite "motion is thought." Effort or conatus in the Infinite seeking for realization could do so only because thought was the *prius* of such realization. We have written as above in order to take the reader another step with Swedenborg in the working out of his principles.

In an earlier work he developed his idea of motion in considerable detail. This was a laborious preparation for *The Principia*; this work he left in MS.; it has now been translated, and will be found under the title *The Minor Principia*, forming a part of volume II. of the present work. In this essay he expresses himself perhaps a little more fully on the primary question than in the later treatise; but he takes over his main ideas with him in writing the published work. Geometry or mathematics he regards as having a similar origin. "Those who desire to search out the matter," he says, "will find that natural philosophy and geometry have the same origin. If according to our thesis,

<sup>1</sup> *Helmholtz Memorial Lecture.*

there is nothing in nature that is not geometrical, then the origin of nature and geometry must be acknowledged to be the same.”<sup>1</sup> Arguing, therefore, that from the non-perceptual geometrical point, the line, the area, and the solid are produced, he concludes that the primary result of infinite motion, effort or conatus realizing itself was a point. “ We, therefore,” he says, “ carry our reasoning through these infinities up to a certain primarily existing entity or point. For we can only define this point as having originated from infinite motion in an infinitely small space; consequently from such infinity something definite existed, that is, the first natural point from which all other things derive their origin; and together with this very point geometry, or nature bounded by geometrical laws, was born. This point seems to be something between the Infinite and the finite.”<sup>2</sup>

In *The Principia*, the later work, he remarks : “ Thus does rational philosophy first acknowledge something produced from the Infinite, and some simple as the origin of entities not simple. This first entity, or this simple, we call the natural point.”<sup>3</sup> This point is the medium between the Infinite and the finite ; it is undifferentiated ; it is pure and perfect motion, or effort toward motion, a centre of potential motion ; energy *in potentia*. This is the primary result of the Infinite realizing itself.

But it may be objected that this renders the origin of things no less incomprehensible than before. But let it be born in mind that Swedenborg, while endeavouring to trace matter to its origin, makes use of the principle of motion which, as we have previously pointed out, is the basis of modern conceptions in physics. And it may be further objected that the author takes us into the region of the unsubstantial. We would reply that in this he has distinctly anticipated modern ideas. For modern physical science takes us completely into the unsubstantial, non-perceptual region

<sup>1</sup> *The Minor Principia*, vol. ii. of *Principia*, p. 298.

<sup>2</sup> *Ibid.* p. 300.

<sup>3</sup> Vol. i. pp. 53, 54.

of motion ; and although refusing to take us up to the primary source, it deals with motion absolutely as a working principle. "Matter," says Dr Gustave Le Bon, "may be considered as a particular form of energy."<sup>1</sup> He remarks further : "I have shown that one of the most constant products of the dissociation of matter was the so-called particle of electricity, deprived, according to the latest researches, of all material support."<sup>2</sup> And let the reader consider carefully the following words by another scientific writer : "It often happens that in inverting a problem the truth drops out. Copernicus, instead of assuming that the sun moved round the world, succeeded better by assuming that the world moved round the sun. Kant, also, instead of assuming that knowledge must conform to objects, inverted the idea by assuming that objects must conform to our knowledge. In a similar fashion it is now proposed to invert the conception of matter and electricity that we have so far gained. Instead of assuming that corpuscles are particles of matter possessing the properties of negative electricity, we shall assume, instead, that corpuscles are particles of negative electricity possessing the properties of matter. It will be seen that this new way of looking at things will lead to new knowledge. It is proposed in this chapter to show by arguments adduced from facts that *Matter is made up of Electricity and nothing but Electricity.*"<sup>3</sup> And Sir Oliver Lodge says : "1. The theory that an electric charge must possess the equivalent of inertia was clearly established by J. J. Thomson in the Philosophical Magazine for April 1881.

"2. The discovery of masses smaller than atoms was made experimentally by J. J. Thomson, and communicated to section A of the British Association at Dover in 1899.

"3. The thesis that the corpuscles so discovered consisted wholly of electrical charges was sustained by many people, and was clinched by the experiments of Kauffmann in 1902."<sup>4</sup>

<sup>1</sup> *The Evolution of Forces*, p. 80.

<sup>2</sup> *Ibid.* p. 29.

<sup>3</sup> Robert Kennedy Duncan, Professor of Chemistry in Washington and Jefferson College, *The New Knowledge*, p. 179.

\* *The Ether of Space*, pp. 95, 96.



Matter, then, is now interpreted in terms of electricity and is no longer a substantial entity, but is resolved into motion, or electric charges which are considered to be a form of motion.<sup>1</sup> When, therefore, Swedenborg saw in motion the origin and completion of things he had a wonderful prevision of the truth.

The point originating from potential motion in the Infinite is kinetic, and, as we shall see, gives rise to a universe. Infinite Will has now realized itself, and has become kinetic in an entity. If matter is electricity and nothing more, and electricity be a form of motion, then the universe in its complex details is electricity, or a form of motion. If this be the case, and at present there seems no reason to doubt the truth of it, then we owe it to modern science that we are in a position to apprehend conceptually what Swedenborg means by infinite, absolute motion *in potentia* realizing itself in a point and in a universe that is consequently and necessarily interpreted in terms of motion. The nexus between the finite and the Infinite becomes now a possible concept.

Although this may be met with a direct negative, we nevertheless can bring forward a philosopher who in certain ultimate conclusions is fairly in line with Swedenborg. Herbert Spencer, after a profound and profuse analysis of the human faculties and their capacities, and after blocking out a vast region in the supposed world of knowledge as actually unknowable, finds himself bound to make an admission. He states, and states in no uncertain terms, that there is a Power behind all phenomena. "Thus," he says, "the consciousness of an Inscrutable Power manifested to us in all phenomena, has been growing ever clearer; and must be eventually freed from its imperfections."<sup>2</sup> Consciousness of a thing implies the formation of a concept; and Spencer's statement amounts to the formation of a concept of an Inscrutable Power. This Power then is a manifested Power, a Power

<sup>1</sup> This is not regarded by Prof. Silvanus P. Thomson as proved.

<sup>2</sup> *First Principles*, p. 108.

realizing itself in all the phenomena of the Universe. “ Its universal presence,” he says, “ is the absolute fact without which there can be no relative facts.”<sup>1</sup> Let us take this Power as equivalent to the Infinite with which Swedenborg sets out. Further, let us see what Spencer has to say in regard to this Power now designated an “ Inscrutable Existence.” “ But one truth,” he says, “ must grow ever clearer—the truth that there is an Inscrutable Existence everywhere manifested, to which he can neither find nor conceive beginning or end. Amid the mysteries which become the more mysterious the more they are thought about, there still remains the one absolute certainty that he is ever in presence of an Infinite and Eternal energy from which all things proceed.”<sup>2</sup> From these words it is legitimate to infer that the Power or Inscrutable Existence postulated is the source of “ the Infinite and Eternal Energy from which all things proceed,” that this energy or motion *in potentia* in this Inscrutable Existence becomes kinetic, or motion in action, in giving rise to the universe.

There is, then, a remarkable parallel between Spencer and Swedenborg here. Swedenborg postulates an Infinite which he says is “ utterly incomprehensible,”<sup>3</sup> Spencer assumes an “ Inscrutable Existence.” Swedenborg says that in the point,, which is the primary result of motion in the Infinite, or in its motion, is the very quality or actual power of producing other finites, and indeed in succession all those which collectively form the world ” ;<sup>4</sup> “ in the primitive force of which all things are latent.”<sup>5</sup> Spencer says that all things proceed from “ an Infinite and Eternal Energy.” In both cases the universe has come into existence from motion. Spencer evidently does not question the reasonableness of assuming a *nexus*; neither do we, with such a critical philosopher as an illustrious example before us. Spencer having deliberately committed himself to this position, which we think both a reasonable and necessary

<sup>1</sup> *Psychology*, vol. ii. cap. xix. end.

<sup>2</sup> *Ecclesiastical Institutions*, p. 843.

<sup>3</sup> *The Principia*, vol. i. p. 63.

<sup>4</sup> *The Principia*, vol. i. p. 79.

<sup>6</sup> *Ibid.* vol. ii. p. 164.

one, it seems to us to be a legitimate inference from his premisses that there was a reason why the “ Infinite and Eternal Energy ” proceeded in such a way from the “ Inscrutable Existence ” as to produce a universe in which science finds a rational order.

Swedenborg differs from the ordinary scientist in fearlessly stating what his opinion is in regard to end or purpose ; and the following words are worth careful consideration and thought.

“ If then it be admitted,” he says, “ that the first simple was produced by motion from the Infinite, we are at the same time bound to suppose, that in the producing cause there was something of will that it should be produced; something of an active quality, which produced it; and something intelligent producing it thus and not otherwise, or in this’ particular manner and in no other; in a word, something infinitely intelligent, provident, powerful, and productive. Hence this first point could not come into being by chance, nor by itself, but by something which exists by itself ; in which something there must also be a kind of will, an agency, and an understanding that the production takes place thus and not otherwise. There must likewise be some provident design, that the effect produced be successively modified in a particular way and no other ; and that by this series, certain particular contingencies and no others should arise. All this must of necessity have been in some way present in this first mode and motion : for in this particular and first motion of the Infinite, things future and coming to pass can be considered in no other way than as if they were present and already in existence.”<sup>1</sup>

This is a clear and lucid statement of a position from which there seems to us to be no escape except by a direct negation. Without recurring to our previous argument on this point we will, as a conclusion, quote words by a modern writer who, in discussing the design argument, considers that particular piece of reasoning as too narrow. “ It is not the marks of purpose

alone," he says, " which necessitate the inference that the universe has a wise and intelligent author, but everything which bespeaks order, plan, arrangement, harmony, beauty, rationality in the connection and system of things. It is the proof of the presence of *thought* in the world—whatever shape that may take. The assumption on which the whole of science proceeds—and cannot but proceed—in its investigations is, that the system it is studying is intelligible—that there is an intelligible unity of things. It admits of being reduced to terms of thought. There is a settled and established order on which the investigator can depend."<sup>1</sup>

The first natural point which Swedenborg discusses is indivisible ; to divide it would be to annihilate it. This necessarily follows from the fact that it is pure motion. Following out Swedenborg's theory we find that a simple finite results from the point or points. Motion becomes embodied in a finited entity, which " derives its existence from the motion of the points among themselves; and is thus the first substantial."<sup>2</sup> From this substantial all other finites are derived; it therefore enters into and permeates all existences ; and he remarks, " if all first substances of which compounds consist, were resolved, there would remain in the universe only simples or points."<sup>3</sup> The conception of motion still follows up this finite. It is motion which finites and limits. "An aggregate of points cannot be finited or terminated except by motion."<sup>4</sup> Motion dominates everywhere in Swedenborg's principles. It is motion which gives rise to a second finite from the first. And here he makes the significant remark that, " it is motion which gives both figure and space."<sup>5</sup> Referring back to his treatment of the first natural point we find that this idea is more fully enlarged upon in a way that calls to mind certain modern conceptions. " Motion itself," he says, " which is merely a quality and a

<sup>1</sup> Professor James Orr, *The Christian View of God and the World*, p. 102.

<sup>2</sup> *The Principia*, vol. i. p. 80.

» *Ibid.* p. 82.

<sup>4</sup> *Ibid.* p. 84.

<sup>6</sup> *Ibid.* p. 107.

mode, and nothing substantial, may yet exhibit something substantial, or the resemblance of what is so, provided there is anything substantial put in motion. If some small body is moved in the direction of a line or circle, there is immediately produced by the motion the semblance of a line or a circle; although there is nothing substantial in it, except that small body in the place which it occupies. If now the motion be very rapid, so that in a moment the body is present in innumerable places, during that moment it makes all that space, wherever it is present, substantial. By motion alone, therefore, something resembling what is substantial can be produced.”<sup>1</sup> Elsewhere<sup>2</sup> he puts the matter in fuller detail. “ Let us imagine,” he says, “ some small corpuscle, or aggregate of small parts, to be moved very rapidly, either in a circle or otherwise. This motion will give rise immediately to a figure or form different from the original one. A very rapid motion proceeding from one point to another will give rise to a line ; the movement of the line laterally describes an area; and the motion of the area from one position to a lower marks out a solid, although merely the very rapid and reciprocal fluxion of a corpuscle, line or area is involved. So, too, if the same corpuscle revolves round a centre with a very rapid circular motion, a circle will be described ; if a semicircular line rotates on a diameter, a complete surface will be represented ; and so on, as is well known. A corpuscle thus moving can represent form by its celerity and direction, or something which previously had no existence, and which is quite different from the corpuscle itself; and it is in every way a figure so far as our senses and touch are concerned, although it is *merely motion* which produces the effect; or by means of motion form is fixed.”<sup>2</sup>

He returns to this later when, in the development of his theory, he shows that the first finite becomes an active force by

<sup>1</sup> *The Principia*, vol. i. p. 75.

<sup>2</sup> *Certain Points bearing on the First Principles of Natural Things* at the end of vol. ii. of the present issue, p. 535.

passing into local motion. This entity is most perfectly active and endowed with a considerable power of acting upon the nearest finites. In this active there is nothing substantial with the exception of that one which alone is in a state of motion. On the basis of this assumption he says " A surface may be represented by motion just as if it consisted of substantiate only." <sup>1</sup>

Now we want to connect this up with some considerations which show that Swedenborg in the above statements is in line with modern conceptions. If, as Sir Oliver Lodge says, " electricity is the fundamental substance out of which atoms of all sorts are built up " <sup>2</sup> ; and if electricity is a form of motion then what we are accustomed to regard as line, surface or solid are motion and nothing more, and Swedenborg's contention that by motion a surface or solid can be formed, is definitely proved; for his first finite or substantial is the aggregate of points which themselves are pure motion. We think the parallel we have drawn above is fairly complete.

A surface, says Swedenborg, can be represented by motion, and it is pretty well established that motion imparts rigidity. A circular flexible chain becomes a rigid wheel by motion. It is said that a jet of water moving with a high velocity cannot be cut through with a sword. It may also be assumed that water falling over a barrier in an extremely thin sheet, moving with the velocity of light, would be impenetrable even by a shell from a Dreadnought. A circular disc of tissue paper, if its tension could be maintained, and caused to make a hundred thousand revolutions per second, would cut through steel as though it were butter. Motion imparts rigidity.<sup>3</sup> Mertz <sup>4</sup> says : " Two of the most suggestive ideas by which physical science has benefited in the nineteenth century are the successful explanation of the dead pressure of gases by a rapid transitional, and of the rigidity of solid bodies by a rapid rotational motion of matter."

<sup>1</sup> *The Principia*, vol. i. p. 139.

<sup>2</sup> *Modern Views of Electricity*.

<sup>3</sup> See further, *Spinning Tops*, by Professor J. Perry, F.R.S.

<sup>4</sup> *History of Scientific Thought*, vol. ii. p. 6.

It is not our purpose to follow the author throughout all the complex details of his finites and actives; we refer the reader to Appendix A, where the subject is carefully discussed with certain details, in which it is shown that Swedenborg was not always clear and accurate in his calculation of the spiral and other motions of his actives. But we would remark, here, that the first finites or substantials by effort towards axillary and local motion become confluent and form a second finite.

A further advance is now made, and we find that by the first finite passing into local motion we have an Active, designated the Active of the first Finite. An active and a passive are the fundamentals by which all subsequent results are worked out. By thus compounding and recompounding of finites we arrive at a series of elements.<sup>1</sup>

We have, then, actives originating out of first substantials and passives, which are first substantials not running into local motion, but acted upon. There results from this what the author designates a first element. "Before anything elementary can exist," he says, "it is necessary that in the world there should be two things, one active and the other passive; one which is perpetually in local motion, another which is not in local motion. . . . These twin-born entities, which are so averse to each other, coalesce into one figure. . . . The particle thus produced I call the first elementary. . . . It is composed of second finities and of actives of the first finite."<sup>2</sup> This elementary particle has a vortical motion ; it is a compendium of the whole world-system. It derives its inherent motion from the points which in a final analysis really compose it. It might perhaps be compared to a vortex ring. Subsequently, there arises a second elementary particle, designated the magnetic element. This consists of third finites on the surface and actives of the second and third finites in the internal space. These elementary particles are

<sup>1</sup> See author's preface, vol. i.

<sup>2</sup> *The Principia*, vol. i. pp. 156, 157, 158.

subject to a vortical or spiral motion. "These spiral gyrations," he says, "which arise from a certain active centre, we may, in what follows, call vorticles, and every gyration round its own proper centre, a single vorticle,"<sup>1</sup> and he further compares this to the motion of our planetary system. "The motion of one large system is latent in a least system."<sup>2</sup> He also says further that: "In every vorticle round the magnet there are probably minute particles moving about the centre and revolving round an axis ; such as is the case in every vortex in the heavens."<sup>3</sup>

As we have previously endeavoured to show that Swedenborg anticipated certain modern ideas, so we will draw the reader's attention to a singular resemblance, in the further development of his theory, to the modern conception of matter. But we would remark in passing that it should be now quite evident that there is hardly any resemblance between the particles of Descartes and the finites, actives and elementaries of Swedenborg. Let us give a summary of Descartes' position as put by George Lewes : "The substance which fills all space," he says, <sup>a</sup> according to Descartes must be assumed as divided into equal angular parts. This substance being set in motion the parts *are ground into a spherical form*, and the *corners thus nibbed off like filings, or sawdust*, form a second and more subtle kind of substance. There is beside a third kind of substance, coarser and less fitted for motion. The first kind makes luminous bodies, such as the sun and the fixed stars; the second makes the transparent substance of the skies, etc." The only resemblance that we can trace in the particles of Descartes to the finites of Swedenborg is that they are subject to whirling movements or vortices.

We now come to consider more specifically Swedenborg's conception of the nature of matter—points, primary substantial, or first finite, from this derivative finites and actives resulting from free motion amongst these, and then *Oriq primary element* formed of second finites and actives. This he defines

<sup>1</sup> *The Principia*, vol. i. p. 241.      <sup>2</sup> *Ibid.* p. 223. <sup>3</sup> *Ibid.* vol. ii. p. 153.



in the following terms: “ This element is the most attenuated, the first and most universal of our mundane system and of the universe in general. It consists of the smallest elementary parts. In every system, both the greatest and the least spaces are occupied by this element. All things in the starry system appear, as it were, present by means of it. It is by virtue of this element, therefore, that we can contemplate the remotest stars and also the planets by their reflected light.”<sup>1</sup> It will be seen that this corresponds to what is now termed the luminiferous and all pervasive *ether*. Again : “ That it is the most universal element may be concluded *ci priori*, because it is the origin of all subsequent elements; because, also, it consists of the smallest constituent parts, can occupy the smallest spaces, and be present where no other element can.”<sup>2</sup> And earlier he says : “ Because this first element is the most universal, passing through all the vortices, and is a contiguous medium between the eye and the sun as well as all the stars of the heavens, it follows that it is the most universal element of our own solar vortex.”<sup>3</sup> Swedenborg, in addition to this primary element, endeavours to account for three others, a magnetic element, a third which he designates ether, and a fourth the air element. All these elements result from finites, and are dimensionally different. To the two latter he assigns different functions. The magnetic element is the cause of magnetic phenomena, and the other the medium for the propagation of light and heat.

Although, without prejudice, we desire to give Swedenborg a very high place as a speculative scientist, still we do not regard his statements as sacrosanct; for while some of his deductions touch modern science at many points, others are questionable in the light of rigid scientific proof. But if his third element is open to question as the medium of light, there is a remarkable resemblance between his first element and the ether of modern theory, known as the luminiferous ether. The undulatory theory of light, which ascribes the phenomenon

<sup>1</sup> *The Principia*, vol. i. pp. 187, 188.

<sup>2</sup> *Ibid.* pp. 187.

<sup>3</sup> *Ibid.* pp. 181, 182.

of light to an all pervading medium, was doubtless known to Swedenborg<sup>1</sup> through the writings of Huygens — who died when the former was seven years old—a theory taken up by Euler and established on a sound basis by Young.<sup>2</sup> When he published his *Miscellaneous Observations connected with the Physical Sciences*, he seems to have been feeling his way toward his theories. He then appeared to have the idea that light was a particle that could run between ether particles.<sup>3</sup> Later, however, in the same work, he says that “according to the corpuscular hypothesis it follows that light is nothing more than undulation of the rays, or than vibration of the ether.”<sup>4</sup> And in reference to light and sensation he puts the matter in quite a modern form : “ As, therefore, sensation must be the result of some kind of motion, and as every minute motion is undulatory and vibratory, I therefore think that we may properly assume that vision is due to the undulation of rays in the membranes of the eye.”<sup>5</sup> Seven years later he wrote the *Minor Principia*, where he speaks of undulatory pressure as the cause of the sensation of light, while in 1749 he conceives a third element as the light medium.

But the tendency of modern speculation is to trace all phenomena to the ether. Whether it is the source of gravitation is not yet determined. Light, as Clerk Maxwell showed, is an electromagnetic disturbance of the ether. Ether is not gross matter ; and it answers to none of the tests of matter. Sir Oliver Lodge says : “ I should prefer to say that ether is not matter at all. It may be the substance or substratum or material of which matter is composed, but it would be

<sup>1</sup> From the very beginning Swedenborg taught that light is produced by the undulatory motion of an elastic ether, and that colours are produced by the modification of this motion in the material objects receiving it. He developed and modified the theory from time to time, but that it was originally derived from the older workers, from Descartes, Huyghens or Hooke, is clear from Swedenborg's earlier works.—Alfred H. Stroh in a preface to Swedenborg's *Miscellanea de Rebus natriralibus*, p. xxxiv.

<sup>2</sup> Thomas Young was born in Somersetshire in 1773. His “Course of Lectures on National Philosophy ” was published in 1807.

<sup>3</sup> *Miscellaneous Observations*, p. 86.

<sup>4</sup> *Ibid.* pp. 104, 105.

<sup>5</sup> P. 105.

confusing and inconvenient not to be able to discriminate between matter on the one hand and ether on the other.”<sup>1</sup>

Although we would strongly object to ascribe to Swedenborg more than his due, yet we venture to say that, as in other departments of science already indicated, so in this he had a remarkable power of drawing deductions and arriving at conclusions since established by the observations and experiments of modern scientific men, and in the light of our remarks above, and quotations from authorities, we conclude that what Swedenborg designates the first element is the equivalent of what science calls ether. It is all pervading, extends through all space, and is the medium by which light from the remotest stars reaches us. His mind seems to have continued to dwell upon this subject; for seven years after the publication of *The Principia* we find him again writing on the question of the *substantia prima* and discussing the question of series and degrees in accounting for the derivation of this primal substance. He would seem to have been influenced in this new line of thought by the writings of Wolff,<sup>2</sup> his contemporary. At the time of writing his *Principia* he had not met with the works of this distinguished thinker, for he remarks at the close of this treatise : “ The principles laid down in the present work had been formulated and committed to paper two years before I had an opportunity of consulting his works.”<sup>3</sup> In 1741 he published his *Economy of the Animal Kingdom*, and it is in this work that the influence of Wolff becomes evident. Indeed, he makes specific references to the *Cosmologia G-eneralis*. And we must assume that this change of attitude towards, or perhaps his mental advance in physical questions, was due to the study of this book, and the fresh domain of thought opened up before him by his anatomical studies in his search for the nature of the soul. However that may be, we now find him discussing the nature of *auras*, a term

<sup>1</sup> *The Ether of Space*, p. 108.

<sup>2</sup> Born at Breslau, 1679 ; died at Halle, 1754.

<sup>3</sup> *The Principia*, vol. ii., Conclusion.

not found in *The Principia*. But almost incidentally he makes a remark in the *Economy of the Animal Kingdom* which seems to us of the greatest importance in arriving at the fundamental connotation of the phrase “ First Element ” used in *The Principia*. Speaking of the first aura he remarks as follows : “ No impression upon it is lost, but passes unimpaired into the whole atmosphere, showing that there is a perfect agreement of all its parts and that each part corresponds in its character to the whole universe, not to mention other characteristics of which I have spoken in my *Principia*, part i. chap, vi., where I have called this aura *the first element of the world*.<sup>1</sup> Now the quotations from the later work which we shall give show that this aura or, first element of the world, has acquired in the development of his mind characteristics with which he had not endowed it in the earlier treatise.

“ The first aura of the world is not matter for neither weight nor lightness can be predicated of it; but on the contrary *active force*, the origin of weight and lightness in terrestrial bodies. ”<sup>2</sup> Again, “ The first aura of the world has no inertia, no materiality, so far as materiality involves inertness and gravity.<sup>3</sup> And a further significant remark is the following : “ This aura is the very and most perfect force of nature and form ... it knows nothing of resistance or of weight/ ”<sup>4</sup> The characteristics of ether as shown above could hardly be expressed more succinctly. Swedenborg, then, by a kind of intuition had a prevision of what modern science by extensive research is establishing on a very firm basis. For it is now agreed “ that ether is a substance very different from matter, that it has no weight, is immaterial in the usual acceptation of that word, and forms the imponderable world.”<sup>5</sup> Notice now the following remark of Swedenborg. “ The first aura is the matter from which other things are derived.”<sup>6</sup> Is

<sup>1</sup> *The Economy of the Animal Kingdom*, part ii. n. 312.

<sup>2</sup> *Ibid*, part ii. n. 311.

<sup>3</sup> *Ibid*, part ii. n. 166.

<sup>4</sup> *Ibid*, part i. n. 638. <sup>6</sup> Dr Gustave Le Bon, *The Evolution of Matter*, p. 91.

<sup>6</sup> *The Economy of the Animal Kingdom*, part i. n. 636.

it not remarkable, then, how fully he is in line with modern results ? As we have seen he regards the first aura, the first element, the universal all-pervading substance, as the origin of the material universe. And Sir Oliver Lodge says: " All mass is mass of the ether, all momentum, momentum of the ether; and all kinetic energy, kinetic energy of the ether." <sup>1</sup>

Passing from the apparent identity of Swedenborg's first element or aura with the ether we have now to consider our author's ideas of motion in relation to the modern conception of the atom. We would beg the reader to dismiss from his mind the supposition that we hold a brief for Swedenborg; we simply desire to make it evident, that, as in the case of Democritus, Lucretius, Dalton, Faraday, and others, we find the anticipation of modern ideas, so also in Swedenborg do we find a prevision of certain modern conceptions. Amid much that is entirely out of date in his scientific works there are to be found great ideas which so far resemble present scientific beliefs that we might almost suppose them to have been worked over in the course of modern investigation, did we not know that his works are practically unknown to the world of science.

The history of the atom goes back to the time of Democritus, who held that the plenum of space, in contrast to the void, consists of indivisible, primitive particles or atoms which are distinguished from one another, not by their intrinsic qualities, but only geometrically, by their form, position and arrangement. These atoms are all subject to motion. Centuries saw little change in fundamental ideas of the atom ; and it was reserved for Dalton to place it in, what was supposed to be, an assured position. Human thought, however, is not a fixed quantity, old ideas form a suggestive region out of which the mind evolves new conceptions. The desire to trace back the eighty or so elementary substances to an original simple undifferentiated matter caused thinkers to be sceptical about atoms as simple, unchangeable, indivisible

• <sup>1</sup> *Ether of Space*, p. 107.

and indestructible. In 1872 Herbert Spencer held that “ The proportion of the different elements result from differences of arrangement, arising by the compounding and recompounding of *ultimate* homogeneous units.”<sup>1</sup> In the course of the evolution of ideas on this question Sir William Crookes brought forward evidence of the existence of radiant matter. In 1895 came the discovery of the X-rays. Then followed the experiments of Henri Becquerel, who discovered the power of salts of uranium to emit radiations which affect the photographic plate, to pass through metals and other opaque substances, and discharge electrified bodies. Then in 1898 came the epoch-making discoveries of Monsieur and Madame Curie, which resulted in making known radium to the world. A new era had dawned in the story of the atom, and the old conceptions of its indivisibility and indestructibility became a matter of history. On August 16, 1905, Professor G. H. Darwin, in the course of his address before the British Association at Cape Town, said: “ Within the last few years the electrical researches of Lenard, Rontgen, Becquerel, the Curies, and of their own colleagues Larmor and Thomson, and a host of others, had shown that the atom was not indivisible, and a flood of light had thereby been thrown on the ultimate constitution of matter. By various convergent lines of experiment it had been proved that the simplest of all atoms—that of hydrogen—consisted of about 800 separate parts, while the number of parts of the atom of the denser metals must be counted by thousands. These separate parts of the atom had been called corpuscles or electrons, and might be described as particles of negative electricity. The mechanism was as yet obscure whereby the mutual repulsion of the negative corpuscles was restrained from breaking up the atom, but a positive electrical charge, or some equivalent, must exist in the atom, to prevent disruption.” Here, then, we have a complete revolution in scientific ideas on the nature of the atom. The ancient atom

<sup>1</sup>*The Contemporary Review*, June 1872.

now becomes a kind of centre of positive electricity with a sphere of negative electricity. Instead of the atom being an eternal, stable, indivisible solid *minimum*, it turns out to be capable of breaking up and of liberating electrons. In a historic debate at the British Association at Leicester, August 1907, Professor Rutherford said “ that Kauffman had shown that the mass of the electron varied with its speed, and that the whole mass of the atom could be explained in terms of electricity, which meant that the electron was electricity in motion.” Matter is, then, to be interpreted as motion,—motion of electricity, a conception completely subversive of the common idea of that matter which appeals to the senses every moment of our lives. The same authority said also that “ as regarded the atom, Professor J. J. Thomson defined it as a sphere of positive electrification, containing a number of negative particles, commonly called electrons.” Startling as these new ideas are, they are far in advance of the old conception of the nature of the atom, because they involve motion as the fundamental basis of the universe. This we have already seen is Swedenborg’s conception, who states that the universe has been evolved from motion. When *The Principia* was published his views would necessarily be regarded as chimerical and hardly worth consideration; but now we see that, with certain modifications, his position is actually that of the scientific mind to-day.

We will here adduce further opinions on the nature of the atom in order to still further elucidate the position. Sir Oliver Lodge remarks that “ Our conception of matter, if it is to be composed of electrons, is necessarily rather like the conception of a solar system ”;<sup>1</sup> and Carl Synder says: “The atom might be conceived, therefore, as a great swarm or cluster of corpuscles revolving about a mutual centre much as planets whirl about the sun ”<sup>2</sup> ; and a writer sums up the position as follows : “ According to this new conception of the atom, it is a miniature solar system, with a certain number of negative corpuscles

<sup>1</sup> *The Ether of Space*, p. 84.    <sup>2</sup> *New Conceptions of Science*, p. 160.

rotating and gyrating like planets round a nucleus, or within a sphere of positive electricity. The negative corpuscles move in definite orbits round the central nucleus or within the sphere *and also spin with tremendous velocity round their own axes ;<sup>1</sup>* and the stability of the atom depends on an equilibrium of forces.”<sup>2</sup>

Now Swedenborg’s elementary particle consists of an outer sphere of passive finites and an interior of actives. There certainly seems to be a resemblance here to the outer sphere of positive electricity of the atom and the centre of negative corpuscles. Indeed, on turning to his illustration of the first elementary particle, vol. i. p. 158, the reader will see that it might almost stand for a picture of an atom with the exception that the rotation round a centre is not shown. But according to our author the very essence of the elementary particle is motion. He says ; “ The first elementary particle and also the second, have the most perfect aptness and susceptibility to motion.”<sup>3</sup> They resemble a bubble in form. They have a gyratory motion. “ They are perfectly apt for, and prone to motion,” he says, “ and they spontaneously endeavour to enter into a vortical motion, provided there is an active centre round which they can gyrate.”<sup>4</sup> Their motion is vortical or gyratory round a centre, and is spiral, and every gyration round its own centre he designates a simple vorticle. While not following Swedenborg in all the complicated details of his theory, we have stated sufficient, we think, to show that he had a conception which is fairly parallel to modern ideas of the atom. Modern experiment and investigation have led to a result almost identical with Swedenborg’s *d priori* idea.

The scientist may say that even if Swedenborg’s conception is fundamentally true, it has had no influence upon the progress of thought ; but had a study by competent thinkers been made of the work with which we are dealing, his

<sup>1</sup> The statement in italics, which are our own, is doubted by some scientific authorities.

<sup>8</sup> R. C. Macfie, M.A., M.B., C.M., *Science, Matter and Immortality*.

<sup>3</sup> *Principia*, vol. i. p. 234.

<sup>4</sup> *Ibid.* p. 235.



conception of the atom might have long ago revolutionized the ideas of the nature of matter and the structure of the atom. It is certainly a most remarkable thing that Swedenborg's interpretation of matter in terms of motion should resemble the modern view. And further, it is an extraordinary coincidence that Swedenborg should contend that, in the final analysis, matter is motion, and that "pure motion does not necessarily require anything substantial as the basis of its existence" ;<sup>1</sup> and that the following words could be written in the twentieth century : "We are led, therefore, to regard the corpuscle from one aspect as a disembodied charge of electricity. Thus, on this theory, matter and electricity are identified ; and a great simplification of our conception of the physical structure of nature is reached." <sup>2</sup> Whether his scientific works will be studied in future or not, those who admire his genius feel that justice should be done to his name, and, to use words of my co-translator, J. R. Rendell, B.A., "It is very desirable that his precise place in the lineage of science should be determined." <sup>3</sup>

Before we leave the subject of the relation of Swedenborg's idea of matter to that of modern conceptions, there is another point intrinsically associated with it, upon which we would desire to write briefly.

Previous to the discoveries which led to changed views of matter, the scientific world was dominated by the belief that energy is associated with matter, that they are two things not one. A body has potential energy when in a position to do work, and that energy becomes kinetic when work is actually being done, by the body. "According to the most fundamental principles of mechanism," says Dr Gustave Le Bon, "when we communicate to a material body a determined quantity of energy this energy may be transformed, but the body will never give back a quantity

<sup>1</sup> *The Principia*, vol. i. p. 58.

<sup>2</sup> W. C. D. Whetham, M.A., F.R.S., in *Darwin and Modern Science*, p. 569.

<sup>3</sup> Letter to Prof. Fitzgerald.

in excess of that received by it.”<sup>1</sup> But if the new atomic theory be true then the atom must itself be intrinsically a reservoir of energy ; it can produce energy. Scientists, on the basis of the enormous speeds attained by corpuscles, have calculated the kinetic energy, or, as designated, their intra-atomic energy. Dr Gustave Le Bon, on the calculation that the kinetic energy of a body in motion equals the products of its mass by the square of its speed, estimates that, if the atoms contained in one gramme of copper moving with nearly the speed of light were stopped in a second, the kinetic energy would be represented by about six thousand eight hundred million horse-power, sufficient to work a goods train on a horizontal line equal in length to a little over four times and a quarter the circumference of the earth.”<sup>2</sup> We need hardly explain to the reader that when a body in motion is stopped by a body at rest it is said to do work upon that object. A shell from a gun stopped by an ironclad does work in penetrating the armour. The energy possessed by the shell, as to penetrating power, is equal to half its mass multiplied by the square of its speed. The kinetic energy of a corpuscle exceedingly small moving with the speed, say,, of light, one hundred and eighty thousand miles in a second, would therefore be enormous. Suppose a disc the size of a pin’s head to revolve with the speed of light its mechanical power would be equal to several thousands of locomotives. The speed of the corpuscles is so enormous that though exceedingly minute they are able to develop enormous energy. Professor J. J. Thomson estimates that a few grains weight of hydrogen has within it sufficient force to raise a million tons to a height of more than three-hundred feet, and Max Abraham calculates that one gramme weight of corpuscles contains energy equal to 80,000,000 horse-power.<sup>3</sup> Speed then, or motion of the elements of the

<sup>1</sup> *The Evolution of Forces*, p. 14.

<sup>2</sup> Dr Gustave Le Bon, *Evolution of Matter*, p. 40.

<sup>3</sup> See Macfie, *Science, Matter and Immortality*, pp. 85, 86.

atom constitutes their energy ; velocity involves energy. The atom then is the seat of energy, and it is capable of developing it to a very limited extent in certain phenomena, and the potentiality is enormous. Radio-activity is due to an enormous store of energy within the atom itself. The energy of radio-activity is intra-atomic.<sup>1</sup> This intra-atomic energy then is motion. This is a remarkable scientific deduction and marks an epoch in thought upon the nature and potentialities of matter.

The old view of matter and energy was that they were two things. Energy, we now see, is intra-atomic. This is Swedenborg's view. He traces matter to its origin, and finds it in motion. Every derivative from the points has motion necessarily and intrinsically in it. The first elementary particle, as we have seen, is an atomic system, and lineally derived from the point, which is absolute motion. The active which forms the interior of the elementary particle consists of nothing but motion. It is a perfectly active force. We quote the author's own words here. " If in a moving body the velocity is the greatest possible, then its energy of acting will be the greatest possible. If the entity, which is acted upon and which thus acts, possesses any weight, then its energy is augmented in proportion to its weight; although the degree of velocity is enabled to supply what is deficient in mass."<sup>2</sup> This most perfectly active force, then, is the centre of the atomic system, or elementary particle, and, therefore, we think we are completely justified in asserting that in Swedenborg we find the principle of intra-atomic energy implicitly, although not explicitly stated.

A further significant fact in the philosophy of Swedenborg is the way in which he deals with the question of magnetism. He assigns a distinct element to the phenomena displayed by the magnet. In his previous investigations he confesses that he depended on *a priori* considerations ; but here he enters a domain where actual experiment and observation are available.

<sup>1</sup> See Duncan, *The New Knowledge*, p. 174.

<sup>2</sup> *Principia*, vol. i. p. 140.

And he adopted what was practically a wise course ; he drew his deductions from the extensive experiments of Musschenbroek contained in that writer's work, entitled, *Physicæ Dperimentales et Geometricæ*.<sup>1</sup> "There are no experiments with the magnet," he says, "more convenient for our purposes than those which have been lately given to the world by the very learned and sagacious Pieter Van Musschenbroek, who has been so ingenious in the mode of conducting his experiments. In examining, therefore, the phenomena of the magnet, and comparing them with the principles we have already laid down, I shall quote the words of this highly experienced author."<sup>2</sup> His quotations cover more than a hundred and fifty of the physicist's experiments.

Considerable attention had been given to the magnet and its phenomena for more than a hundred years before this period, Dr Gilbert, of Colchester, having published a work entitled *De Magnete* as early as the year 1600. Although the subject has been extensively handled by scientists, the magnet still seems to be involved in considerable mystery.

Every magnet is surrounded with a magnetic field. This field is constituted by lines of force. Faraday attributed to these lines of force a real existence ; for they were to him more than a mere question of mathematics ; and he gave as evidence of the existence of these lines of force the classic experiment of iron filings spread on a card placed above a magnet. A good deal of attention has been given to these lines of force by physicists. They indicate in the first place the direction in which magnetic forces are acting ; but this does not take us very far. Experiment shows that these magnetic lines of force have a very definite position in regard to the magnet, and that they can be very accurately mapped out. By the cutting of these lines of force, electric currents are produced. Their relation to the magnet must be an intrinsic one ; but what is their constitution or structure ?

<sup>1</sup> Published in 1729.

<sup>2</sup> *The Principia*, vol. i. p. 275.

Maxwell regarded them as axes of rotation in the ether. This seems to be about as far as physicists have arrived in their conception of the meaning of lines of forces around the magnet; but nothing in physics is more demonstrable than the existence of this attribute of the magnet.

Now Swedenborg was perfectly aware of this interesting and beautiful phenomenon; and in *The Principia* he has an accurate series of finely executed diagrams of magnets and their lines of force. Such a philosopher was not likely to allow this feature of magnetic phenomena to pass without inventing a theory. In working out his principles he had conceived the existence of a distinct element called the magnetic element, wherein lie the causes of the wonders of the magnet. His conception is that in the magnetic sphere, what are now designated lines of force, are actually axes around which vortices, or what we venture to term atom-systems, move with great velocity, the connection and union of these vortices, atoms or electrons by their poles giving rise to the phenomena of magnetism. The phenomena of attraction or repulsion of poles of opposite or similar names he explains by the coincidence or non-coincidence of the vortices gyrating in spiral paths round their centres. The similarity of this theory to modern views is very remarkable indeed, and is perhaps the most striking of all the views he has advanced in its agreement with recent science.

But we will enable the reader to judge from Swedenborg's own words. "For magnetism itself," he says, "consists in the union of the vortices within and without the mass, and in the confines between the two. The more regular the arrangement, within limits, of the mass the more regular is the arrangement and conjunction of the vortices within the mass. Thus one is connected with another in a continuous series; and all are disposed together more conveniently into one sphere ; a contiguous extension is formed round about from one pole to the other, and vortices in connection with one another

everywhere enclose the mass, bracing it round, as it were.”<sup>1</sup> The following words are supplementary to the above. “In the sphere of the magnet,” he says, “there are spiral gyrations or vortices. In every vortex round the magnet there is an active centre. In every vortex there are probably *minute particles moving about the centre and revolving round an axis*”<sup>2</sup> These axes of revolving vortices, we take it, are the lines of force to which we have referred above. The chairman of the science section at the Swedenborg International Congress, referring to the molecular constitution of the magnet or a magnetized body, said, “With respect to the molecular constitution of the magnet, Swedenborg was clearly the anticipator of the theory attributed to Weber. In this case his diagrams and explanation are very clear and might have been written for a text-book to-day.” “The modern theory,” he continues, “as expounded by Professor Ewing of Cambridge, is that every molecule of a piece of iron is by nature a magnet, but that in an unmagnetized rod the particles have their poles turned in every direction so that they neutralize one another, and, in consequence, they do not produce any external field of force.”<sup>3</sup>

Let us now quote what Swedenborg says in order to show the striking coincidence of his opinion with the above. “By the application of the magnet and iron,” he says, “we observe that in the structure of the iron all the effluvia which are perfectly or partially free are disposed into a regular arrangement and that the iron is thus rendered magnetic. It is for this reason that from a regular arrangement of the parts within the iron magnetism exists.”<sup>4</sup> “No increase of weight is produced in iron by rubbing it against a magnet; but the smallest parts of the iron are drilled into a straight line,<sup>5</sup> and being partly loosened by rubbing against the magnet, are only turned round and brought into a definite order.”

<sup>1</sup> *The Principia*, vol. i. p. 250.

<sup>2</sup> *Ibid.* vol. ii. p. 153.

<sup>3</sup> J. R. Rendell, B.A., in his address, *Transactions of the International Swedenborg Congress*, 1910, p. 49.

\* *The Principia*, vol. i. p. 2G5.

<sup>5</sup> *Ibid.*, 350.

In this connection Swedenborg gives two diagrams which, as Mr Rendell says, "might do duty to-day in Professor Ewing's work entitled *Magnetic Induction in Iron and other Metals!*"

We have now followed Swedenborg throughout his corpuscular philosophy, and we shall presently see the reason why he has taken us through a long and involved discussion of finites and elementaries. From the very beginning his intention has been to show how our world-system has been evolved. As we have seen, he labours to explain his theory of the origin of matter as a preliminary to placing before us his conception of how matter became realized in stars and planets, and the phenomena with which we are familiar. Others had already worked upon the subject, but Swedenborg stands alone in the way he attacked it. If he has not given us scientific theories capable of a measure of proof by experiment, at least brilliant flashes of genius irradiate his pages in his forecast of many modern ideas. He, in fact, deals with the pre-nebular state of matter in a way both original and suggestive. Dr Hastie was apparently unaware of the nature of Swedenborg's speculations when he wrote the following: "It was reserved for the nineteenth century to take up the ultimate problem of the pre-nebular condition of matter. . . . This ultimate problem, indeed, has only been taken up of late years, and we are just beginning to reach some tentative solution of it. It evidently involves the fundamental question of the genesis of the chemical elements, the formation of material particles, the constitution of all matter, and the mode of its primal distribution and arrangement in space."<sup>1</sup> On the contrary, Swedenborg, cutting out a way for himself in an obscure and speculative region, endeavours to account for the genesis of matter as necessary to his nebular hypothesis, his aim being to explain the origin of suns and worlds. As we shall endeavour to prove, when we come to his ultimate issue, he was the first

<sup>1</sup> Professor P. W. Hastie, D.D., *Kant's Cosmogony*, translator's preface, p. 89.

in the field with a bold and remarkable nebular hypothesis. But before we proceed to state his case it is necessary to review some of the main hypotheses that have been given to the world from time to time. Leaving out of account some of the crude but brilliant theories of certain Greek philosophers we find that Descartes was the first to deal with the cosmological problem. He held a vortical hypothesis by which he tried to show that whirling movements arose in the primordial nebulous matter. By this means the great bodies of the visible universe came into existence. To quote Professor Svante Arrhenius' description of Descartes' hypothesis: " God has created matter and its movement. There are three elements in the universe : out of the first, the luminous element, the sun and the fixed stars have been made ; out of the second, the transparent, consists the Heaven; and out of the third, the dark, opaque and reflecting, consist the planets and the comets. The first element is composed of the smallest particles, the third of the coarsest particles. In the beginning matter was distributed as uniformly as possible. Movement induced closed orbits about centres in which the luminous matter was collected, whilst the second and the third matter was whirling round. Of the dark bodies some possessed so powerful a movement, they were of so great mass and had drifted so far away from the centre of the vortex that no force could retain them. These bodies have passed from vortex to vortex, and such are the comets. Bodies of smaller mass and of smaller velocity with the particles of the second element were endowed with the same centrifugal force ; these are planets." <sup>1</sup> Allowing for the obscurity which may be induced by condensing so complicated a subject, the hypothesis of Descartes is crude and fanciful. It lacks the element of reasoned consistency, and that ultimate rounding off which grips and convinces the mind. His theory contains no prevision of future developments, no anticipations of discoveries to come. Yet his views for a

<sup>1</sup> *The, Life, of the Universe*, vol. i. p. 104. The reader should consult Descartes' *Principia Philosophicae*.



long time held sway over his contemporaries and philosophical successors. Of course his contributions to physics and the cosmological problem had their place, in the history of thought, and as Professor Hastie remarks with some truth, "The first form of the Nebular Hypothesis is to be found in Descartes' principles of philosophy published in 1644.<sup>1</sup> "The vogue of Cartesianism," says a writer, "contributed notably to the overthrow of the authority of Aristotle, already broken by thinkers like Galilei and Bacon, and thus rendered men's minds more ready to receive new ideas; in this indirect way, as well as by his mathematical discoveries, Descartes probably contributed something to astronomical progress."<sup>2</sup>

After Descartes came Swedenborg, whose views will be discussed presently, and following Swedenborg, the next name in the history of cosmology is that of Georges Louis Le Clerc Buffon,<sup>3</sup> author of the celebrated *Histoire Naturelle*, published in 1745. He supposed that the planets of our system originated from collisions between the sun and comets. From the nature of the impact he accounted for the movements being all in the same direction. Tremendous heat resulted from the impact; and he determined from incandescent iron balls what would be the probable rate of the cooling of the planets respectively. The sun would ultimately cool down. His theory met with criticism from Laplace. Professor Arrhenius thinks that "Buffon's exposition well deserves a place next to that of Laplace."<sup>4</sup> But while Laplace's theory deserves the name of a Nebular Hypothesis, Buffon's assumes the existence of the sun and a comet; and he further assumed an impact between the sun and a comet, which has never yet been proved to have occurred.

We now come to Immanuel Kant. This distinguished thinker and philosopher was born at Konigsberg in Prussia, April 22, 1724, three years before Newton's

<sup>1</sup> *Kant's Cosmogony*, Introduction, p. 64.

<sup>2</sup> Arthur Berry, M.A., *A Short History of Astronomy*, p. 209.

<sup>3</sup> Born in Burgundy, 1707; died at Paris, 1788.

<sup>4</sup> *The Life of the Universe*, vol. ii. p. 136.

death. He early applied himself to the study of theology, but turned by inclination to the study of philosophy, mathematics and physics. His *General History of Nature and Theory of the Heavens, or an Essay on the Constitution and Mechanical Origin of the Whole Universe treated according to Newtonian principles*,<sup>1</sup> was published in 1755 at Königsberg and Leipsic. The reader will be good enough to make a note of this date as we shall have a particular reason to refer to it later. Kant is best known by his purely philosophical works, which have somewhat overshadowed his earlier treatise. He entered upon this field with a success that indicated at once a remarkable genius for speculative - problems. Whether his cosmology, which has attained such notoriety, was original to him in its fundamental ideas we shall have to examine when we come to deal with Swedenborg's point of view. The estimation in which his cosmological speculations are held we shall show by quotation from some authorities of note.

Professor Hastie has translated Kant's *Allgemeine Naturgeschichte und Theorie des Himmels*, and written a learned and exhaustive introduction. This writer has the highest opinion of Kant's work and theory. He could hardly have expressed himself in terms more eulogistic than the following : " Kant's scientific achievements are original, great, and enduring in all their relations. He was, in this connection, the historical successor of Copernicus, Kepler, and Newton ; the true founder of physical astronomy in its widest range, and the interpreter of its highest spiritual significance. We are but beginning to understand the greatness of his conceptions as he shines upon us again, full orb'd, in all his lustre, after long eclipse ; and all the science of our age may still gather new strength and confidence from his bold thoughts and fruitful suggestion. There can be no doubt that he was specially endowed with the peculiar gift of the scientific mind, and that he used it to the noblest purpose." <sup>2</sup>

<sup>1</sup> *Allgemeine Naturgeschichte und Theorie des Himmels*.

<sup>2</sup> *Kant's Cosmogony*, Introduction, p. 98.

While fully endorsing the above words we would remark that they would have been somewhat modified as regards Kant's cosmological views had the author of them been more<sup>7</sup> fully informed upon the true history of the nebular hypothesis. Kant, then, is highly praised by Professor Hastie and others for his cosmological theory. What is that theory? He postulates a pre-nebular matter. In his own words, "I assume that in the beginning of all things, all the matter composing the sun the planets and comets, must have filled the whole space in which these bodies now move."<sup>1</sup> By some means the particles of which this matter seems to have been composed were attracted towards a centre, which is now the sun. By the collision, these particles would be driven into closed paths.. Further collisions would take place, and finally, by successive aggregation, the planets were formed and revolved about the sun.<sup>2</sup> "Kant's assumption," says J. B. Stallo<sup>2</sup> "is common to all recent forms of the nebular hypothesis that have fallen under my notice—they all postulate a diffusion of the entire mass of the sun, planets, comets, and satellites constituting our planetary system throughout the planetary space."<sup>3</sup>

One defect in Kant's theory seems to us to be the assumption of particles primarily existing without any principle of motion and without any definition of the nature of the particles. Further, how ultimate vortical motion of particles could arise by the gravitation of these primordial particles towards a centre it is not easy to conceive. Whatever difficulties of conception are involved in Kant's cosmogony, his theory seems not to have lost its influence, if we are to believe Dr Hastie's words. Writing in 1900 he says: "Kant's Cosmogony never

<sup>1</sup> Ich nehme an, dass all Materie, daraus die Kugeln die zu unserer Sonnenwelt gehoeren, alle Planeten und Kometen bestehen, im An fang aller Dinge in ihren elementarischen Grundstoff aufgeloes't, den ganzen Baum des Weltgebaendes erfuehlt haben, darin jetzt diese gebildeten Koerper herumlaufen."—*Naturgeschichte des Himmels*.

<sup>2</sup> See Professor Svante Arrhenius, *The Life of the Universe*, vol. ii. p. 138.

<sup>3</sup> *Concepts of Modern Science*, p. 281.

stood so high in the estimation of the scientific world as it does to-day.”<sup>1</sup>

But Kant's name seems to have been destined to be overshadowed by that of the distinguished astronomer and mathematician, Pierre Simon Laplace ;<sup>2</sup> for the nebular hypothesis is now associated with his name. “ Kant,” says Sir Robert Ball,<sup>3</sup> “ outlined with a firmness inspired by genius that nebular theory to which Laplace subsequently and independently gave a more definite form, and which now bears his name.” Laplace supposed that the material now forming the sun and planets existed in a nebulous condition and extended to the limits of our solar system. The planets were formed at successive limits by condensations of this nebulous matter. Arrhenius says : “ Laplace starts from the assumption of a glowing mass of gas which from the very first was in vortex motion from right to left about an axis passing through its centre of gravity.”<sup>4</sup> Dr Hastie contrasts Kant and Laplace's systems as follows : “ Kant starts from the primitive nebula in the universe; Laplace from the nebular disc of our solar system already in rotation. Kant makes sun and planets arise out of certain regions of space through gravitation; Laplace makes masses and rings detach themselves from the central body, through centrifugal force.”<sup>5</sup> Another writer puts it in this way: “ In 1796 Pierre Simon Laplace brought forward his famous nebular hypothesis of a fire-mist which once stretched from the centre of the sun to at least as far as the outermost planet of our system, and which as it cooled and contracted threw off planets as nebulous equatorial rings, which rings again eventually cooled into globular masses and formed planets.”<sup>6</sup> We will give the reader the opportunity of reading Laplace's words by quoting them in full. He

<sup>1</sup> *Kant's Cosmogony*, Introduction, p. 1.

<sup>2</sup> Son of a small farmer, born at Beaumont in Normandy, in 1749.

<sup>3</sup> *The Earth's Beginnings*, p. 6.

<sup>4</sup> *The Life of the Universe*, vol. ii. p. 144.

<sup>5</sup> *Kant's Cosmogony*, pp. 78, 80, quotation from A. J. von Ettinger.

<sup>6</sup> R. C. Macfie, M.A., M.B., C.M., *Science, Matter and Immortality*, p. 117.

remarks : “ From a consideration of the planetary motion, we are brought to the conclusion that, in consequence of the excessive heat, the solar atmosphere originally extended” beyond the orbits of all the planets, and that it has necessarily contracted itself within its present limits. In the primitive state in which we have supposed the sun to be, it resembles those substances which are termed nebulse, which, when seen through telescopes, appear to be composed of a nucleus more or less brilliant, surrounded by a nebulosity which, by condensing on its surface, transforms it into a star. If all the stars are conceived to be similarly formed we can suppose their anterior state of nebulosity to be preceded by other states in which the nebulous matter was more or less diffuse, the nucleus being at the same time more brilliant. By going thus far back in this manner, we shall arrive at a state of nebulosity so diffuse that its existence can with difficulty be conceived. We may therefore suppose that the planets were formed at its successive limits, by the condensation of zones of vapours which it must, while it was cooling, have abandoned in the plane of the equator.”<sup>1</sup>

Laplace is supposed, according to J. B. Stallo,<sup>2</sup> to have been unaware that the hypothesis had been advanced by Kant. There is no evidence to the contrary, but he may, for all that, have been aware of a previous view ; for he had a fine conceit of himself. In spite of the difficulties which modern scientists suppose to be involved in Laplace’s theory considered in detail, there is a refinement about his suggestion which renders it more plausible than Kant’s. The *materia prima* of our solar system in a highly attenuated form extending throughout the limits of our planetary system, cooled and contracted, forming at successive limits the various planetary bodies. This seems to differ from Kant’s theory fundamentally in this : (1) That the diffused nebulous matter is limited to our planetary system, while Kant’s appears to be extended throughout space. (2) The

<sup>1</sup> Note vii. at end. Translated by Dr Hastie.

<sup>2</sup> *Concepts of Modern Physics*, p. 280.

planets and sun are formed by the cooling and condensing of attenuated hot nebular matter; Kant's assumes a kind of cosmic dust from which bodies grew by successive collisions. A more detailed examination of either view would be beyond our purpose; but we have placed the theories of these two distinguished thinkers before our readers for reasons that will shortly appear.

The nebular theory, then, is generally supposed to have taken its form from these two great men ; but before we examine this point, it may be well to state that the nebular hypothesis, as generally accepted to-day, may be put as follows : The matter now constituting the universe formed into stellar, solar and planetary systems was uniformly diffused through space. By the action of forces this diffused matter became divided into large attenuated spheres which began to rotate. As these spheres cooled they slowly contracted, and this contraction led to an increase in velocity in conformity with the mechanical law known as the law of " the conservation of areas of momentum." Sir Robert Ball says : " That a fire-mist such as the solar system required did once exist, must surely be regarded as not at all improbable so long as we can point to the analogous nebulae or fire-mists which exist at the present moment."<sup>1</sup> Modern opinion is, therefore, still in agreement with the underlying idea of Laplace's theory. The same authority writes upon the importance of the nebular theory as follows : " That three different men of science, Kant, Laplace and Herschel, approaching the study of perhaps the greatest problem which nature offers to us from points of view so fundamentally different, should have been led substantially to the same result is a remarkable incident in the history of knowledge. Surely the theory introduced under such auspices and sustained by such a weight of testimony has the strongest claim on our attention and respect."<sup>2</sup> In this high eulogy of a theory and its origination Sir Robert Ball has omitted to give the credit to its real propounder; this-

<sup>1</sup> *The Earth's Beginnings*, p. 269.

<sup>2</sup> *Ibid.* p. 12.

omission, however, we shall shortly proceed to make good ; but in the meantime it is highly interesting to find the nebular theory receiving the support of so high an authority as the one we have just quoted.

Other theories have been mooted to explain the evolution of solar systems, notably the meteoric theory advocated by Sir Norman Lockyer. The latest and most novel of theories yet advanced is the impact or grazing theory of Professor Bickerton, for many years professor of physics and chemistry in Canterbury College, University of New Zealand. This theory is based on the appearance and disappearance of new stars and the phenomena associated with variable stars. He thinks that his theory accounts for both of these, and he extends it to explain how the solar system originated in a deep grazing impact of two suns largely gaseous. If this theory could even be verified by evidence, the existence of grazing suns would require to be accounted for. Professor Bickerton is so fascinated with his theory that he makes statements with the assurance of one who has full evidential proof at hand. For example : “ The two most noted *novae* of late years were *Nova Aurigae* and *Nova Persei*. The new star in Auriga indicated a velocity of about a third of that indicated by the new star of Perseus, this later new star being both more brilliant and more transitory. Hence we conclude that the Auriga collision was a deep graze of small suns, and the Perseus collision was a slight graze of very massive suns.”<sup>1</sup> Professor Arrhenius also favours a collision theory.

Now Swedenborg, contemplating the solar system, and endeavouring to account for it, assumes that this can be done by starting with the origin of matter, as we have endeavoured to explain at some length above. The basis of his conception is motion. Motion results in the coming into existence of an undifferentiated *substantiaprima*. By the differentiation of this we have finites, and arising from these, actives ; and he brings us successively to a vast plenum of what he designates as

<sup>1</sup>See his *Birth of Worlds*.

actives of the first finite; that is, of the *substantia prima*. This plenum he calls the solar space, and it consists of extremely attenuated matter.<sup>1</sup> “Originally,” he says, “there was a universal chaotic condition common to the sun and the planets, in which the origin of all things was latent.”<sup>2</sup> This chaotic condition of this diffused attenuated substance we should now call nebular matter. Whatever view may be taken of the original state of things, whether meteoric or not, the final analysis brings us to a nebular state as preceding the evolution of a solar system. Indeed, the enormous number of nebulae now known to exist, whether spiral, ring shaped, or in a more extended condition, gives a pretty strong proof of the nebular origin of suns and worlds. “The nebulae which show only the spectra of permanent gases, like hydrogen, or products derived from carbon, must constitute, according to several astronomers, the first phase of the evolution of celestial bodies. By condensing they must form new stages of matter which end in the formation of stars.” The same writer remarks again: “If the view set forth in this work be correct, matter must have successfully passed through very different stages of existence. The first of these carries us back to the very origin of worlds, and escapes all the data of experiment. It is the chaos of ancient legends. What was to be one day the universe was then constituted of only shapeless clouds of ether.”<sup>4</sup> “Here in the nebulae,” says Sir Robert Ball, “we find, as it were, substance in its most elementary shape of widest possible diffusion from which worlds and systems, it may be, are yet to be evolved.”<sup>5</sup>

The chaotic or nebular condition having been evolved we must now suppose that the motion, passing on in every stage of this evolution, sets up movement in the vastly extended nebular matter, giving rise to a gyration round a centre forming a vortex which carries round with it all the surrounding material.

<sup>1</sup> See *The Minor Principia*, p. 63.

<sup>2</sup> *The Principia*, vol. ii. p. 178.

<sup>3</sup> Dr Gustave Le Bon, *The Evolution of Matter*, p. 308.

<sup>4</sup> Dr Gustave Le Bon, *The Evolution of Matter*, p. 314.

<sup>5</sup> *The Earth's Beginnings*, p. 50.



This vortex Swedenborg designates the “solar space.” This is the stage to which we are brought in his theory, and we shall now see the reason why he treats at such length of actives and finites evolved from points and carrying motion with them as an inherent and original quality. “The solar ocean,” he says, “seems to consist of the actives of the first and second finite. For it is these actives that are the causes and origin of all the ulterior changes and compositions which occur in our nascent world.<sup>1</sup> These actives were in a constant state of motion at the centre of the vortex.” Still allowing Swedenborg to explain himself we quote as follows : “That the solar ocean existing in the middle of its vortex is the fountain of all the motions which take place between the parts constituent of its world is, I imagine, quite clear, as also that it is, as it were, a perfectly active centre around which the smaller and larger parts are whirled in a perpetual current.”<sup>2</sup> In the earlier treatise entitled *The Minor Principia*, forming part of the second volume of the work of which we are specially writing, Swedenborg, five years before, wrote as follows upon this point : “The solar ocean originated among particles in a most perfect state of rest. In taking its rise it increased and became a kind of vast sea. The particles first accumulated in one place incited motion among the surrounding particles and set up a gyration of a vortical nature.”<sup>3</sup> This gyration of an active centre compressing the surrounding material caused, what he designates actives, to become passive finites. These at length formed a compact sphere around the central gyrating body. These finites, he says, “formed an immense volume and crowded round and enclosed the sun in such a manner as to form an incrustation.”<sup>4</sup> This sun would seem to correspond to the central part of a spiral nebula, of which the photographic plate has given us countless examples. Upon this point he further remarks : “We can therefore conceive of no solar space

<sup>1</sup> *The Principia*, vol. i. p. 206.

<sup>2</sup> *Ibid.* p. 224.

<sup>3</sup> *The Minor Principia*, p. 382.

<sup>4</sup> *The Principia*, vol. ii. p.\* 180.

without surrounding finites or elementaries. If, therefore, there is a solar space, and in its middle the most perfect activity, then, according to our principles, it could not, in the primordial state of things, be surrounded with any other than the finites of the first active, compressed all round into a narrow compass by the action of the space."<sup>1</sup> At this stage in Swedenborg's theory of the evolution of world-systems an impartial student will see a remarkable resemblance to the modern development of the nebular hypothesis. The evidence of the photographic plate makes it quite clear that a vortex movement at sometime arises in the widely diffused nebular material imparting ultimately a gyration to the whole mass resulting in a central body and offshoots therefrom. A careful study of photographs of spiral nebulae will, we think, bear out our contention. We gladly acknowledge that in his work, *Worlds in the Making*, Professor Arrhenius has given a fair and succinct statement of his conception of our author's theory when he says, "Swedenborg assumed that our planetary system has been evolved under the formation of vortices from a kind of *chaos solare*, which had acquired a more and more circulating motion under the influence of internal forces, possibly akin to magnetic forces."<sup>2</sup> But while there are undoubted difficulties in Swedenborg's theory, as there are in all others, it seems to us, that a comparison between this view and the cosmogonies we have purposely sketched above, is distinctly in favour of Swedenborg's, not only because of its relative simplicity, but because it is the result of antecedent considerations which take us back to a definite origin, that origin being motion, on the basis of which nature is now being interpreted by scientific men.

But now let us notice a further stage in the evolution of a world system according to Swedenborg. The solar incrustation by virtue of expansion under the influence of the gyration of the central portion finally undergoes disruption, collapses, forms an equatorial ring around what is now the sun, and at

<sup>1</sup> *The Principia*, vol. i. p. 225.

<sup>2</sup> Page 205.

length differentiates into planetary bodies. His own words are : “ This incrusting matter being endowed with a continual circular motion round the sun, in the course of time removed itself further and further from the active space; and, in so removing itself, occupied a larger space, and consequently became gradually attenuated till it could no longer cohere throughout, but burst, in some part or other. . . . The zodiacal belt formed around the sun burst and formed planets of spherical form.”<sup>1</sup> The student will be able to substantiate this by the study of nebulae in the photographic plate. Some of the spiral nebulae actually show masses which have been broken off from the body and present the appearance of worlds in the making. It would seem then that modern observation pretty well confirms Swedenborg’s theory. The photographic plate has the advantage of presenting a nebula for leisurely study, and such a record pronounces in favour of Swedenborg’s theory rather than those of Kant, Laplace, Lockyer, Arrhenius, or Bickerton. The following words of Sir Robert Ball seem to us to bear precisely on Swedenborg’s theory and to substantiate it in a remarkable manner : “ The great spiral nebula—near the Great Bear—may be considered to exhibit at this moment a system in actual evolution, the central body of which is certainly thousands of times, and not improbably millions of times, greater than the sun. It is manifest that the evolution has reached an advanced stage. In the great spiral many portions of the nebula have already become outlined into masses which, though still far from resembling the planets in the solar system, have, at least, made some approach thereto.”<sup>2</sup> And another astronomer in speaking of the wonderful nebula Andromeda, says : “ The rifts seen in the photograph mark the separation between the central nebula and a ring thrown off from it, seen in perspective ; and we see actually in the sky the state of things which Laplace suggested in his famous nebular hypothesis—a central nebula, which in rotation

<sup>1</sup> *The Principia*, vol. ii. p. 183.

<sup>2</sup> *The Earth’s Beginnings*, p. 195.

throws off a series of rings, some of which break up to form satellites.”<sup>1</sup> We could quote much more from different writers to the same purpose; but there is no need to do this in the face of the facts we have placed before the reader.

But now let us follow Swedenborg still further in our investigations. Taking the earth as an example of the rest of the planets, he tells us that when, in the breaking up of the belt round the sun, the earth had been sent spinning on its way, it began to describe a spiral path, marking out an ever increasing orbit, and continually withdrawing itself from the central body. He perhaps falls into error in relation to the period during which the earth reached its orbit, but he undoubtedly states the matter approximately. “From what we have already stated,” he says, in the chapter on the progression of the earth, “It is evident that the earth had already travelled a considerable distance from the sun ; that as soon as it began its course freely through the vortical region, it began to rotate on its axis, and revolve round the sun ; that at first it described only small circles, then gradually larger ones, according as it reached a greater distance from the sun. At first the years were only of short duration. In the course of time the duration of its years was gradually extended until they finally reached their present limits.”<sup>2</sup> He says again : “There was a time when the earth in completing its year occupied only a few of our present days.”<sup>3</sup> This is a necessary outcome of his theory; and here again we are glad to be able to quote Sir Robert Ball on this very point. After arguing the question at some length he says, “Thus we look back to a time at the beginning of the present order of things when the day was only some three or four hours long.”<sup>4</sup> And our author says in a later work re-echoing his earlier view: “There was a time when the earth moved over the disc of the sun like a spot.”<sup>5</sup> But before we leave this point we

<sup>1</sup> Prof. Herbert Hall Turner, *Modern Astronomy*, p. 236.

<sup>2</sup> *The Principia*, vol. ii. p. 268.

<sup>3</sup> *Ibid.* p. 284.

<sup>4</sup> *Time and Tide*, p. 76.

<sup>5</sup> *De Cultu et Amore Dei*.

desire to call the reader's attention to the interesting fact that Swedenborg visualized his theory ; he drew a series of remarkable and interesting sketches to illustrate it, a task accomplished neither by Kant nor Laplace, we believe. The representations are ingenious, and give the reader a general, if rough idea, of what he meant to convey.

We now come to another interesting point in Swedenborg's Cosmology. The planets themselves threw off satellites just as the sun had cast off the parent bodies, and the moon like the earth must have taken a spiral path in attaining its orbit, and been originally much nearer the earth than it is at the present time. Swedenborg's theory bearing on the planets is, then, consistent also in its application to the satellites. Here again we are able to adduce the opinion of modern astronomers, arrived at quite independently of Swedenborg's view. Sir Robert Ball says : " It has been supposed, and there are some grounds for the supposition, that at this initial stage of earth-moon history the moon materials did not form a globe, but were disposed in a ring which surrounded the earth, the ring being in a condition of rapid rotation. It was at a subsequent period accordingly that the substances in the ring gradually grew together, and then by their mutual attraction formed a globe which ultimately consolidated down into the compact moon as we now see it." <sup>1</sup> The reader will see a striking analogy between this feature of a moon-ring round the earth and the great radial belt round the sun in Swedenborg's theory. The same author says again : " It is now known, mainly by the researches of Prof. G. H. Darwin, that in all probability the moon was originally a part of the earth, and that a partition having occurred while the materials of the earth and the moon were still in a plastic state, a small portion broke away to form the moon, leaving behind the greater mass to form the earth. Then under the influence of the tides, which may agitate a mass of rock, as the moon once was, just as they agitate an ocean, the moon

<sup>1</sup> *Time and Tide*, p. 96.

was forced away and was ultimately conducted to its present orbit.”<sup>1</sup> The point is more fully elaborated by the same authority as follows: “Let us now look at the moon and examine where it must have been during these past ages. As the moon is gradually getting farther and farther from us at present, so looking back into the past, we find that the moon was nearer and nearer to the earth the further back our view extends. In fact, concentrating our attention solely on essential features, we may say that the path of the moon is a sort of spiral which winds round the earth gradually getting larger though with extreme slowness. There was a time many millions of years ago when the moon was only 100,000 miles away. Nor can we stop our retrospect; we must look further and further back, and follow the moon’s spiral path as it creeps in and in towards the earth, until at last it appears actually in contact with that great globe of ours.” “Surely,” he continues, “the tides have then led us to the knowledge of an astounding epoch in our earth’s past history, when the earth is spinning round in a few hours, and when the moon is, practically speaking, in contact with it.”<sup>2</sup> Nothing more conclusively in agreement with Swedenborg’s general principles, and particularly as shown in the diagrams illustrating it, could be imagined than the statements contained in the above quotations, we therefore take it that our author’s anticipations of modern results are hereby pretty well vindicated.

We have brought the reader thus far in the study of our subject; but before we pass to one or two other points of interest in Swedenborg’s deductions, we wish to examine the claim to priority in regard to the three chief cosmological systems that we have had under discussion.

We have already shown by quotation from authorities that a nebular hypothesis in some form or other is considered as thoroughly established. To Kant is almost unanimously

<sup>1</sup> *The Earth's Beginnings*, p. 254.

<sup>2</sup> *Time and Tide*, p. 77.

ascribed the origin of the theory. "Kant," says Sir Robert Ball, "outlined with a firmness inspired by genius that nebular theory to which Laplace subsequently and independently gave a more definite form, and which now bears his name."<sup>1</sup> J. B. Stallo, comparing the claims of Kant and Laplace, says, "But the truth is that the nebular hypothesis in the form in which it is now generally held is due to Kant."<sup>2</sup> Neither of the above writers mentions Swedenborg in this connection. Either they ignore his views, or have no knowledge of them. And Professor Hastie, who published in 1900 an important work specially devoted to Kant's cosmology, mentions Swedenborg in passing, and with evident want of knowledge of his system. In fact, Swedenborg has been generally left out of account by astronomers who have written on cosmology. We have, however, recently noticed some interesting exceptions. Professor Arrhenius, the celebrated Swedish Physicist, in his Introduction to the Latin reprint of Swedenborg's *Cosmologica*, has given him his right place and also in his recent work *The Life of the Universe*. Professor Sollas, in Harmsworth's *History of the World*, says, "It was not until the middle of the eighteenth century that the reign of evolution began, and attempts were made to trace the history of a planetary system from its source as a primeval nebula on mechanical grounds. Swedenborg was the pioneer in this direction."<sup>3</sup> Another writer, J. Morrison, the astronomical editor of *The World Almanack*, 1910, in an article on Earthquakes, properly gives Swedenborg the credit. "The cosmogony of our solar system rests on the nebular hypothesis first profounded by Swedenborg, but not generally accepted in his time; it was, however, subsequently revived and partially confirmed by the researches of Sir William Herschel. At a still later date it was examined by the celebrated Laplace, and it

<sup>1</sup> *The Earth's Beginnings*, p. 6.

<sup>2</sup> *Concepts of Modern Physics*, p. 280.

<sup>3</sup> P. 12.

is erroneously known as the nebular hypothesis of Laplace. It should, however, in all justice, be called the nebular hypothesis of Swedenborg.” And lastly, an astronomer writing lately on the priority of Swedenborg, says, “ I imagine that very few among us realize the position held by Swedenborg in connection with this matter.”<sup>1</sup>

It is evident from the above references that scientific men are becoming better informed on the point at issue, and that Swedenborg is likely in time to come into his own. It is only fair and just that a great thinker and philosopher should have that place assigned to him in the history of thought which is properly his due. We will now bring to a focus the lines of evidence bearing on Swedenborg's priority which give conclusive proof of the fact which we have set out to establish. The testimony of incontrovertible dates will put the matter beyond cavil.

1729. Swedenborg writes a work, now called the *Minor Principia*, in which the main points of his cosmological theory are outlined. This important document remained in MS. until recently.

1734. Swedenborg publishes his *Principia* in which his theory is definitely stated and illustrated with diagrams.

1745. Buffon publishes his *Histoire naturelle*.

1755. Kant publishes his *Natural History of the Heavens*.

1796. Laplace issues his *Systbme du Monde*. Kant was ten years old when the *Principia* was published, and therefore when the German philosopher wrote his *History of the Heavens*, Swedenborg was sixty-seven years old, and apparently either knew nothing of Kant's work or was too much ab-

<sup>1</sup> Letter of Mr A. M. W. Downing, D.Sc., F.R.S., F.R.A.S., to the *Journal of the British Astronomical Association*, in reference to the paper on *Swedenborg as a Cosmologist* read at the Swedenborg International Congress, 1910.



sorbed with other functions to give attention to it.

Swedenborg's claim, then, is fully established by the above dates, and he stands out as the first cosmologist of real significance. But whether Kant owed his idea to Swedenborg is a moot point. It is certain that he was acquainted with some of Swedenborg's works, but whether he had studied the *Principia* it is impossible to say. After careful study we are driven to the conclusion that as there are important differences between the cosmology of Kant and Laplace, so the system of Swedenborg and that of Kant are so fundamentally different as to have little relation the one to the other. The reader has the outlines of the two conceptions before him and can therefore judge for himself. We now leave this matter of priority, as completely substantiated, with a final quotation from Professor Nyr&n. "It cannot be denied," he says, "that the essential part of the nebular hypothesis—namely, that the whole Solar System has been formed out of a simple chaotic mass, which first rolled itself together into a colossal ball, and subsequently, by rotation, separated a ring from itself, which then—during the continued rotation, broke up into several parts, and finally contracted into planetary masses, was first expressed by Swedenborg. It should further be observed that he has, in all probability, given his hypothesis the more correct form, that the planets were formed out of broken-up rings, not, as Kant supposed, immediately out of conglomerations formed from the original mass of vapour."<sup>1</sup>

We have not yet come to the end of Swedenborg's anticipations of modern conceptions, and we must claim the readers' attention while we examine one or two other points.

Swedenborg advanced a brilliant idea of the nature of the universe as a whole. He held the view that "The whole

<sup>1</sup> *Vierteljahrsschrift der Astronomischen GeseUschaft*, 1879.

visible heaven is one large sphere, and its suns or stars, together with their vortices, are parts of a sphere connected one with another in the way we have mentioned.”<sup>1</sup> And again, “The common axis of the sphere or starry heavens seems to be the galaxy, where we see the greatest number of stars. Along the galaxy all the vortices are in a rectilinear arrangement and series and cohere as to their poles. . . . The other solar or stellar vortices afterwards proceed from the axis and are bent in different directions, but nevertheless all have reference to the axis. ... In the Milky Way lies the chain and magnetic course of the whole of our sidereal system.”<sup>2</sup> On the basis of this we must imagine the stars arranged in an orderly manner over the surface of a sphere, closely grouped together apparently in the galaxy and more sparsely scattered over the sphere as they recede from the galaxy or Milky Way towards the galactic poles. Swedenborg speaks of the galaxy as an axis, but he would seem to mean by this that the Milky Way is a kind of equatorial ring engirdling the sphere and forming the basis on which the sphere is built up, the galactic poles being the imaginary terminations of the axis through the galactic equatorial circle. Moreover, as each star is the centre of a world-system or smaller sphere, he regards all these systems in the Milky Way as connected by their poles, somewhat like the vortices in the lines of force around the magnetic. All the other systems scattered over the sphere have their axes or poles directed towards the galaxy. Therefore, he says, “the other solar or stellar vortices afterwards proceed from the axis and are bent in different directions.”<sup>3</sup>

It must be admitted that this is a magnificent conception, indicating a mental grasp of the nature of the universe to which there was no parallel among his contemporaries. No scientific man appears to have noticed this brilliant idea, and hardly one seems to be aware of the fact that Swedenborg was the first in the field with a conception now generally accepted

<sup>1</sup> *Hie Principia*, vol. ii. p. 156.

<sup>2</sup> *Ibid.* p. 160.

<sup>3</sup> *Ibid.*

by astronomers. Here is the evidence. “ Thomas Wright of Durham,” says Professor Hastie, “ was the first to propound the idea that the stars are not scattered without order or connection in space, but have a systematic arrangement or constitution,, like the solar system, whereby they are all bound into one universe, unity and connection.”<sup>1</sup> Dr Hastie, as usual, is ill informed upon the genesis of this question. As a proof that Kant was not a student of Swedenborg’s *Principia*, we may observe that he was unaware that this wonderful conception was contained therein ; for he seems to have met with the idea in Wright’s work. Mr Macfie says “ It is interesting to know that Kant was inspired in his brilliant speculation by a summary in a Hamburg paper of a *New Theory of the Heavens* by one Thomas Wright, son of a Durham carpenter.” And Kant’s own words, quoted by Dr Hastie, are as follows : “ I cannot exactly define the boundaries which lie between Mr Wright’s system and my own; nor can I point out in which details I have merely imitated his sketch and carried it further.”<sup>2</sup>

This Thomas Wright, M.A., published his work in 1750., sixteen years after Swedenborg’s *Principia*. The book is very rare, and hardly any of the writers who refer to his theory would seem to have read it at first hand. There is a copy of it in the British Museum Library. It is a curious blend of scientific speculation, bad theology, and poetical quotation. We give here the words in which he states his theory, “ How absurd it is to suppose,” he says, “ one part of the creation regular and the other irregular, or a visible circulating order of things to be moved with disorder, and a part of an endless confusion, is obvious to the weakest understanding, and consequently we may reasonably expect that the *Via Lactea* or Milky Way,, which is a manifest circle among the stars, conspicuous to every eye, will prove at least the whole to be together a vast and glorious regular production of being out of the will and

<sup>1</sup> *Kant’s Cosmogony*, Introduction, p. lxvi.

<sup>2</sup> *Science, Matter and Immortality*, p. 116.

fecundity of the eternal infinite, one self-sufficient cause ” (Letter vi. and end).<sup>1</sup>

This theory has been taken up by astronomers. Herschel collected numerical data and worked out in detail the consequences of this fundamental hypothesis.<sup>2</sup> Newcombe elaborates the theory, and says that the stars increase from the galactic poles to the Milky Way. “ The stellar system,” he remarks, “ is built up with special reference to the Milky Way as a foundation.”<sup>3</sup> Lastly we will quote Professor Arrhenius, who says, “ The suggestion is thrown out by Swedenborg that the Milky Way played in the stellar universe the same part as the rotational axis of the sun within the planetary system. According to this notion the suns with their planetary systems would lie grouped about the great axis of the universe, which would run through the Milky Way.”<sup>4</sup> Here again we see that Swedenborg was first to give to the world a most brilliant conception ; but as in other matters he has not been allowed to bear the palm. Dr Hastie in his enthusiasm says, “ Thomas Wright is only now receiving a belated justice at the hands of contemporary English writers upon science.” The recognition of Swedenborg’s merits and the acknowledgment of his extraordinary genius is becoming, slowly but surely, an accomplished fact, and we believe that Dr Hastie’s words, with another name substituted, will find fulfilment in the course of time.

We will conclude our observations on this point by quoting words bearing on his brilliant theory of the universe, so majestic in their sweep, and so remarkable in their conception that they deserve a place in the history of scientific ideas.

<sup>1</sup> The full title of this work is: “ An original Theory or New Hypothesis of the Universe. Founded upon the Laws of Nature and solving by mathematical principles the General Phenomena of the Visible Creation and particularly The Via Lactea comprised in Nine Familiar Lettej-s from the Author to his Friend. And illustrated with upwards of Thirty Graven and Mezzotinto Plates By the Masters. By Thomas Wright of Durham. London, m d c c 1 .”

<sup>2</sup> See *History of Astronomy*, p. 334, by Arthur Berry, M.A.

<sup>3</sup> *Side Lights on Astronomy*, p. 38.

<sup>4</sup> *The Life of the Universe*, p. 116.

“ New heavens, one after another,” Swedenborg says, “and new creations may arise in endless succession. How many myriads of heavens, therefore, may there not be—how many myriads of world-systems. There may be innumerable spheres or starry heavens in the finite universe, and the whole visible heaven is perhaps but a point in respect to the universe.”<sup>1</sup>

It was in 1729, as we have before stated, that Swedenborg wrote *The Minor Principia*; this he left in MS., and it has now been translated. In this work many remarkable ideas are to be found, besides those we have had occasion to refer to in our remarks. One to which we now desire to call attention is undulatory pressure. It is now established that light exerts pressure ; by means of such pressure the sun drives minute particles even out of his system. Dr Poynting deals with this subject in his little work entitled *The Pressure of Light*. He tells us that light can be shown by experiment to exert pressure. “ It is just a hundred years,” he says, “ since Thomas Young killed the corpuscular theory of light and founded in its place the theory that light consists of waves, but there was no reason at that time to suppose that the waves could press, and so experiments to detect light-pressure ceased for nearly a century.”<sup>2</sup> In 1873 Clerk Maxwell enunciated his electro-magnetic Theory of Light, a theory now universally accepted. His calculations on light-pressure showed that strong sunlight falling perpendicularly against a black surface exerts a pressure of about two-hundred-thousandth of a grain on a square inch. Now light is produced by waves or undulations, and we might call the pressure resulting therefrom undulatory pressure. Dr Poynting says, “ It is interesting to know that whatever kind of waves we imagine, so long as they have the properties which we observe in light, these waves must press against the surface from which they start, and they must press against the surface on which they strike. They must, in fact, carry

<sup>1</sup> *The Principia*, vol. ii. pp. 161, 162.

<sup>2</sup> P. 15.

momentum with them just as surely as if they were moving particles on the old corpuscular theory. The fundamental idea of the proof is, that a train of waves is somewhat like a compressed spiral spring. The waves contain energy.”<sup>1</sup>

Singularly enough, words almost similar to the above were written by Swedenborg one hundred years ago. “Undulatory pressure,” he says, “is the cause of sight, light, and colour. It extends from the sun to the earth. There is in light nothing which cannot be explained by the rules and mechanism of undulatory pressure.”<sup>2</sup> With slight reservations, these words are so remarkable that they might almost be supposed to be a quotation from a modern text-book on science, and particularly since he believed that there is an all-pervading medium or ether. As a matter of fact it is pretty well established that pressure does extend from the sun to the earth, and that by means of radiant pressure that body “drives the finest particles altogether away from his system.”<sup>3</sup> Let us then quote again from Swedenborg: “That an undulation from the sun,” he says, “and pressure from the same can be maintained throughout so great a distance as to our earth arises from the perfectly regular arrangement and connection of the particles.”<sup>4</sup> This inference Swedenborg drew from his *h priori* principles, for there were no means of experimentally proving it in his day. It was not a guess but a true inference from the theory on which he was working in the earlier treatise. The electronic theory of matter which has displaced the old solid atom idea, and to which the views of Swedenborg so nearly approximate, as we have shown above, fully substantiates the conception of radiant pressure. Professor Arrhenius refers to the question of radiant pressure in his book the *Life of the Universe*. He refers therein to Maxwell’s wonderful prediction of the amount of radiant pressure, and he states that it was he himself who showed in

<sup>1</sup> Dr Poynting, *The Pressure of Light*, p. 21.

<sup>2</sup> *The Minor Principia*, no. 130.

<sup>3</sup> *The Pressure of Light*, p. 82.

<sup>4</sup> *The Minor Principia*, no. 129.

1900 the importance of this new universal force. Further, the explanation of the Aurora Borealis is now based on the phenomena produced by radiant pressure. Electrons emitted by the sun, as the result of the light-pressure exceeding the attraction of gravitation exercised on such minute particles, are driven through the space of ninety-three millions of miles into our atmosphere. When these minute bodies enter the earth's magnetic field, they follow the lines of force in spirals towards the poles. On their way certain gases are electrified, causing them to phosphoresce, and thus give rise to this wonderful northern phenomenon.

While writing these words it is reported that a new star has appeared in the constellation Gemini. When first seen it was estimated to be of the fourth magnitude. On March 19<sup>th</sup>, according to Dr Rambaut, Radcliffe Observatory, Oxford, this star had already begun to wane. New stars have frequently been noted by astronomers; and the phenomena presented by them has been explained by observers in various ways. Dr Bickerton's theory, to which we have already referred, tries to account for the fact by a collision between two suns. Lockyer considers the phenomenon to be the result of collision between meteoric showers. Huygens explained it as arising from the near approach of two gaseous bodies. It is said that observation has shown a tendency in a new star to develop into a nebula. In August 1901 photographs were obtained of a nebulosity round a new star in the constellation Perseus, showing remarkable condensations.

It is interesting to observe here that Swedenborg notices the remarkable fact of the rise and wane of new stars. We merely mention his theory to show how he tried to account for the phenomenon. The vortical centre of nebulous matter becomes incrustated ; the sun-centre is obscured and becomes invisible ; then the disruption takes place, the planetary bodies are thrown off, and the new star becomes visible. The waning of the light may be due in some way to the decrease

of energy after the disruption of the incrusting nebulous matter. Swedenborg's words on this point are as follows: "Stars have been known to come into view, and after a lapse of time to grow obscure and become invisible : then again to become visible, and again obscure; so that either they disappear altogether, or else, unless some neighbouring stars should in the meantime occupy their vortex, remain permanently in sight. Here then we see the planets actually imaged forth to the eye. We see, as it were, the same incrustations arising from the compression of the circumfluent elementary parts, and veiling over the star or sun to which they belong; we see also their repeated dissipations and separations. Astronomy is full of evidence of phenomena of this kind, and continues to this very day to offer to the eye these representations of the chaotic condition of which we have been speaking."<sup>1</sup> Our author here quotes from David Gregory's *Astronomiae Physical et Geometricae Elementa* <sup>2</sup> in which there is a full account of the new stars that had appeared up to that date. The words that follow the quotation are remarkable as indicating the cause of "dead suns." "From these statements it is evident," he says "not only that stars are seen to come into view in the heavens, but that afterwards they form around themselves another element, and in course of time become incrustated; that in this state of incrustation, being situated among so many neighbouring stars that are arranged in their own sphere in regular order, they are unable to bring any vortex around themselves to perfection, and consequently always remain in a state of suspended formation; that, therefore, they become incrustated, continue in their state of incrustation, and thus remain concealed from view."<sup>3</sup>

The further discussion of this and other questions would take us beyond the limits of this Introduction, and now we leave it, having come to the end of our task. And we venture to believe that sufficient evidence has been adduced to show

<sup>1</sup> *The Principia*, vol. ii. p. 191.

<sup>2</sup> Published in 1702.

<sup>3</sup> *The Principia*, vol. ii. p. 194.



the remarkable character of Swedenborg's claims, his brilliant inductive capacity, his far-reaching perceptive power, and his extraordinary insight into problems which led him to anticipate some of those modern conceptions which are now regarded as triumphs of thought and research. Although his achievements were practically ignored by his contemporaries and have been neglected by succeeding generations, yet we venture to designate him the greatest genius of his age and the Democritus of the eighteenth century.

Is a i a h T a n s l e y .



## TRANSLATORS' PREFACE.

In the year 1734 Emanuel Swedenborg issued his great scientific work, *Opera Philosophica et Mineralia*, in three large folio volumes, the size of the type page being 9| by 5^ inches. The first of these volumes is entitled *Principia Rerum Naturalium sire Novorum Tentaminum Phoenomena Mundi Elementaris Philosophice Explicandi*.

Since his death two manuscripts on the same subject have come to light. They were first reproduced by photolithography, and in 1908 a finely executed transcription of the original Latin was issued under the auspices of the Royal Swedish Academy of Sciences, the editor being Mr A. H. Stroh, M.A. The present work comprises a translation of these three treatises.

The *Principia Rerum Naturalium* was first rendered into English by the Rev. Augustus Clissold, M.A., a clergyman of the Anglican Church, in 1845, and published by W. Newbery, 6 King Street, Holborn. It has been out of print for many years.

Of the posthumous works, the larger one, now called the *Minor Principia*, is translated for the first time. Of the shorter manuscript, entitled a *Summary of the Principia*, a version from the pen of Mr A. H. Stroh was published in America in 1904, under the auspices of the Swedenborg Scientific Association.

The translation into English of scientific treatises written so long ago is not an easy task, for it is very difficult to enter into the spirit of an age so distant from our own and so scientifically different. To-day, technical terms in physics and cosmology are so clear and definite that we can hardly

compare them with the somewhat vague expressions of a past age. To-day a physicist writes of acceleration (r<sub>pj</sub>), force

$\sqrt{ML}$  work  $\sqrt{ML^2}$  J, power  $\sqrt{MIA}$  having the correspond-

ing definite mathematical formulae in his mind. But in Swedenborg's day, though Newton's *Principia* was available, there was no such definiteness of vocabulary, and the word *vis* had in consequence to do many duties. Indeed, it is stated in the *Popular Encyclopaedia* of Newton's *Principia* that "not more than two or three of his contemporaries were capable of understanding it, and that more than fifty years elapsed before the great physical truth which it contained was thoroughly understood by the generality of scientific men."

It is very probable that if the modern vocabulary were uniformly inserted in the English version, the reader might infer the existence of conceptions that were not in the author's mind. We have been very careful to give the nearest equivalents to the author's expressions, and we have not even attempted to modernise his multiplication of degrees (of arc) by degrees.

Some readers may question the usefulness of printing the mathematics on pp. 121 and 129 and the mass of figures in connection with the determination of the magnetic meridian in Vol. II., for the mathematics are incomplete and unsatisfactory, and the predictions have not been fulfilled. We have, however, gone over the tedious calculations, and ventured to correct a few errors in the logarithms that were probably due  
\* to the printer. The main arguments, however, with respect to the cosmos are independent of the mathematics, and we doubt whether any mathematician of his day could have given correctly the equation to the curve he tries to describe. It was, however, felt best to print the works as they issued from the writer's pen ; it would have been a difficult task to select portions for issue. The reader now has the whole of the

works before him, and can judge of their merits more justly than if selections had been arbitrarily made. —

We have omitted certain diagrams found in the original edition, for to these no references are to be found in the text.

On p. 121 we have called attention to difficulties in the mathematics of the spiral curve postulated by the author. Mr Very, of the Astrophysical Observatory, of West wood, Mass., U.S.A., in a valuable appendix, discusses this question at length and provides the necessary solution. He also critically examines other matters in the work, adding thus a valuable means for the study of it.

We have been assisted by many persons in our labours. We cannot speak too highly of the help given by Mr Very. Prof. C. R. Mann, of the Ryerson Physical Laboratory of the University of Chicago, kindly read the proofs of the first volume, and gave valuable hints as to the second. The Rev. F. Sewall, D.D., of Washington, and Prof. Enoch Price have also greatly assisted in the work. The late Rev. James Hyde spent much time and labour at the British Museum in verifying all the references to all the authorities mentioned or quoted in the work. He also compiled an appendix of biographical notices, and compiled an index of names of writers mentioned in the volumes.

The whole of the work has been done jointly by the undersigned. The first volume was translated by Mr Rendell and the second by Mr Tansley, who is responsible for the *Minor Principia* and the two sections that follow. Both translators collaborated in carrying out and completing their labours.

James R. Rendell.

Isaiah Tansley.



# CONTENTS OF VOLUME I.

## PART I.

CHAP.	Pr e f a c e .	.....	PAGE XCV
I.	The means leading to True Philosophy, and the True Philosopher .....		1
II.	A philosophical argument concerning the First Simple of the world and its natural things ; that is, concerning the First natural point, and its existence from the Infinite .....		51
III.	A philosophical argument on the First or Simple Finite, and its origin from points ....		79
IV.	A philosophical enquiry concerning the Second Finite, and the manner in which it seems to have originated successively from the Simple Finite. Also, general observations on its co-existent, which may be called the Active of the First Finite ; and on the manner in which it is geometrically derived from the First and Simple Finite .....		106
	General observations on the coexistent of this Finite, which we call the Active of the First Finite .		130
V.	Observations specifically on the Active of the First Finite ; its origin from the First Simple Finite; its motion, figure, state, and other attributes and modifications, showing that this active is one, and constitutes the sun of our system ; that it also forms the first elementary particles .....		134
	Whether there is any active belonging to the point; and if so, what is its nature ?		154
VI.	The First and most Universal Element of the world-system, or the First Elementary particle compounded of finites and actives ; its motion, figure, attributes and modes ; its origin and composition from the Second Finite and the Active of the First Finite ; it constitutes the solar and stellar vortices .....		156
	A geometrical discussion of the form, and a mechanical discussion of the arrangement and motion of the parts and of the compound, in Finites, Actives, and Elementaries .....		189

CHAP.	PAGE
VII. The Actives of the Second and Third Finite . . . . .	197
The Actives of the Third Finite . . . . .	206
VIII. The Third Finite or Substantial . . . . .	211
IX. The Second or Magnetic Element of the world ; that is, the next Elementary particle composed of third finites and of the Actives of the Second and Third Finite. Its motion, form, attributes, and modes. This Element, together with the former, constitutes the solar vortex, and is the one which principally contributes to the phenomena of the magnet . . . . .	216
X. The existence of the sun and the formation of the solar vortex . . . . .	224

PART II.

I. The causes and mechanism of magnetic forces . . . . .	233
II. The attractive forces of two or more magnets, and the relation of the forces to the distances—	
A priori, or from first principles . . . . .	268
The same argued a posteriori or from experiments ;	
Musschenbroek's experiments . . . . .	274
Experiments i.-v. ....	279-284
III. The attractive forces of two or more magnets when their poles are alternated—	
A priori, or from first principles . . . . .	288
Musschenbroek's experiments, vi.-viii. . . . .	289-291
IV. The attractive forces of two magnets when their axes are parallel, or when the equinoctial of the one lies upon the equinoctial of the other—	
A priori, or from first principles . . . . .	292
Musschenbroek's experiments, ix.-xii. . . . .	294-296
V. The disjunctive and repulsive forces of two or more magnets when opposite poles, or those of the same name, are applied to each other—	
A priori, or from first principles . . . . .	297
Musschenbroek's experiments, xiii.-xv. . . . .	304-311
VI. The attractive forces of the magnet and of iron—	
A priori, or from first principles . . . . .	312
Musschenbroek's experiments, xvi.-xxii. . . . .	318-341
VII. The influence of a magnet upon heated iron—	
A priori, or from first principles . . . . .	342
Musschenbroek's experiments xxiii. . . . .	344-346



*CONTENTS.*

xci

CHAP.	PAGE
VIII.	The quantity of exhalations from the magnet, and their penetration through hard bodies— A priori, or from first principles . . . . . 347----- Musschenbroek's experiments, xxiv.-xxviii. . . . . 351-371
IX.	Various ways of destroying the power of the magnet; and chemical experiments made with it— A priori, or from first principles . . . . . 372 Musschenbroek's experiments, xxix., xxx. (twelve processes) . . . . . 376-409
X.	The friction of a magnet against iron, and the force communicated— A priori, or from first principles . . . . . 410 Musschenbroek's experiments, xxxi.-xliv. . . . . 416-433
XI.	On the attractive force of a magnet acting upon several pieces of iron— A priori, or from first principles . . . . . 434 Musschenbroek's experiments, xlv.-cxxviii. (Method of arming magnets, 464-467) . . . . . 435-509
XII.	The action of iron and the magnet upon the mariner's needle ; and the reciprocal action of one needle upon another— A priori, or from first principles . . . . . 510 Musschenbroek's experiments, cxxix.-cxxx. . . . . 515-518
XIII.	Other methods of making iron magnetic— A priori, or from first principles . . . . . 519 Musschenbroek's experiments, cxxxi.-cxlvi. . . . . 523-543
Appendix	..... 544



SERENISSIME PRINCEPS

LUDOVICE RUDOLPHE,

DUX BRUNSVICENSIIUM ET LUNEBURGENSIUM, ETC.

Antiquis ritus fuerat, si aliquis illorum ex numero Deus votis annueret, sive thure arae ejus injecto litaret, quod voti sui compotes facti vel solverent quod voverant, vel sertis, verbenis, et vittis aras ejus cingerent: sique opulenta fuisset domus, quod bidentes ad altaria ejus mactarent; vel annua vel menstrua vota solennesque pompas ducerent; si vero pauperes essent Lares, quod aliquibus farris aut thuris flavi micis foco altaris ejus injectis, devoto magis animo et mussitante simul ore, sacra facerent, et ei grates agerent, et pro exiguis illis donis, ut iterum vota sua secundaret, precari ausi essent: verbo, secundum rei familiaris sortem et fortunam, templis ejus tanquam sui tutelaribus, et inter numerum deorum maxime faventibus, propitii et secundantis, honores instaurabant, et altaria donis struebant. Ipse, cum ante duodecim quod excurrit annos, Vestrae Serenitati aliquas micas hujus farris sive tenues pagellas rudis et incomtae Minervae porrigere ausus sim, laete recordor, quod illis visis, tamen annuere et favere dignatus sis; quod cum mihi voti secundi argumentum fuerat, hinc, sed ignoscas, secundum ritum antiquorum, ad aram Tuam redeo, et quamvis non divites honores templis indicere, bidentes niveos mactare, et Tibi pompas ducere queam, usque tamen acerram jam thure ejusdem generis sed pleniorum in grati animi pignus porrigere ausim; quumque litaverint olim micse tantummodo illius farris porrectae, spero id iterum, acerra pleniorum jam muneri votivo

oblata: permitte ergo, ut opusculum hoc Principiorum novorum plenum Te ut sui Tutelarem adoret, utque Philosophia hsec nova, ante Tuas aras, Tibi sacra et votiva, quum melioribus donis operari nequeo, veniat. Non orbem literatum latet, qualis Minervse et literarum ejus Cultor et Amator sis ; qualis cultorum ejus Tutela et Favor; his fretus, propius propiusque accedere et veniam poscere ausim, et ut votis annuas, precari; si iterum annuis et faves, voti secundi faustissima auspicia erunt. Vive Serenissime Dux tot annos, quot in templis et ad aras pro annis et salute Tua vota redduntur: quod devotissime precor

**SERENITATIS VESTRÆ**

Perhumillimus cultor

**EMANUEL SWEDENBORG.**

# PREFACE.

## A SUMMARY OF OUR PHILOSOPHY.

I fear lest, at the very threshold and outset of our philosophy, especially its First Part, my readers should straightway be deterred from proceeding further, when they meet with views which appear strange and different from those generally received ; and also such unusual terms, as Finite, Active, Elementary ; terms as yet unknown in philosophical works ; that is, which are not applied to mechanics, geometry, and the elementary world. For this reason it will be requisite for me to give, by way of preface, a summary of our work, and a key to its contents.

Every one, from the light of reason, may see that nature, conforming to principles of geometry, is ever pursuing a most simple course, a course peculiar to herself, and truly mechanical. He may likewise see that all things in the world arise from what is uncompounded, and therefore from a single fountain-head and a primitive cause; that this primitive cause enters into the various things that are caused (a truth which necessarily follows, if further entities are to be derived from those which have already been brought into existence); also that there could have been no other cause than the one which had proceeded by descent, as it were, from its first parent or simple. This cause, therefore, must be latent in the first simple; and there must enter a similar cause into the first entity derived from it. Now since the world deduces its origin and subsequent increments, by means of a connected contiguous series, from the primary or

single end through intermediates to another end; and since there must be present a cause, and indeed an efficient and active cause, before anything can be produced in a series; it follows that there must be a passive, an active, and as a product from both, a compound, or elementary. If therefore there is anything of a composite kind, it must consist of two principles, a passive and an active ; without these nature herself would be, as it were, in a state of celibacy, destitute of progeny, without a derived entity, without any new efficient, without effect, without series, without phenomena; in a word, without worlds, I have therefore tried to show that in the Finite, which is the first in successive derivation from the Simple, is contained each principle, both passive and active, from which, by the accession of a contingent or physical cause, arose the Composite or Elementary ; and further, that in every derivative, whether Finite, Active, or Elementary, there always coexists a similar cause, and consequently a similar power of producing an effect, namely, from the one into the other ; thus, as it were, from one power into another, from one degree into another, and so on farther and farther. So also in the derivatives there is latent a principle similar to that which exists in the primitives ; in composites a principle similar to that which exists in simples; in effects a principle similar to that which exists in causes ; consequently also that nature in her kingdoms, and especially the elementary, is in the cause and in the effect simultaneously: so that from known principles of mechanism, under the guidance of geometry and by the analytical faculty of reasoning, we may, from an effect visible and posterior, safely draw our conclusions not only with regard to effects invisible and prior, but with regard to the very entities which are active and passive ; indeed, to the very cause which is latent in all.

I wish then, in a few words, to give a summary of the whole philosophy ; and in so doing begin from the first Simple. I make therefore the following statements :—(1) In a Simple there is an internal condition tending to a spiral motion, and

consequently there is in it a similar endeavour to produce it.

(2) In the first Finite that results from it, there is a spiral motion of the parts ; it is the same in the other elementary-----  
 Finites, in all of which there is thus a similar principle.

(3) From this single cause there arises in every Finite a progressive motion of the parts, an axillary motion of the whole, and if there is no obstacle, a local motion of the whole.

(4) If there is a local motion, there arises an active, similar to the agent producing it, and differing only in degree and dimension. From this it is clear that we admit of entities only of a threefold degree, namely, Finites, Actives, and Composites, or Elementaries, which are compounded of the two. With respect to Finites we say that one is generated by the other ; and that all the Finites of the class thus arising, are very similar to one another, and differ only in degree and dimensions. Hence the fifth Finite is similar to the fourth ; the fourth to the third ; the third to the second ; the second to the first; and the first to its own proper Simple : so that he who knows the nature of one knows the nature of all. So also we say, that Actives are very similar to one another ; that the fifth, fourth, third, second, and first Active are all of the same nature ; differing only in dimension and degree, in the same way as Finites. That Elementaries also are similar to one another, since they are compounded of the Finite and Active; the Finites occupying the surfaces, the Actives the interiors ; that consequently the first, second, third, fourth, and fifth Elements are all similar to one another ; so that he who knows the nature of one knows the nature of all. We say that in every Finite there are three motions, namely, a Progressive motion of the parts, an axillary, and a local motion, if there is no obstacle ; nor am I aware that in these extremely simple entities any other natural motions can be assigned ; or, if we grant the motions of these entities, which no rational person would deny, that any other could be assigned more conformable to nature. We remark further, that all these motions proceed from one fountain-head, or from one and the

same cause, namely, from a spiral motion of the parts. This motion, because it is most highly mechanical, is also the most highly natural; being that in which, as is well known, the whole potency of nature and all mechanical force is inherent. And if it be granted that motion is the cause of things, then no other motion can be admitted than that which is most highly mechanical and geometrical; for, from its centre to its circumferences in space, a spiral is a continuous thing, tending to the circular in all its dimensions ; and as such it cannot possess in itself anything but what is most highly perfect, mechanical, and natural in its motion ; being both as to the situation of its parts and as to its motion most highly geometrical. In a Simple, however, in which there can be nothing substantial to be put in motion, nor any medium in which motion can exist, we must conceive that instead of a mechanical and geometrical motion, such as there is between parts and in some medium, there is, as it were, a total or pure motion, that is to say, a state and an effort hence arising from a similar toward a similar *quasi* motion; in which the one only cause and primitive force that produced all the entities subsequently existing is latent.

Because in all its kingdoms the visible world is so diversified, and consists and subsists in a series of parts successively and simultaneously arising, it cannot possibly have its termination in the same point in which it had its beginning ; thus it cannot possibly have its termination in its own first or mediate series or line of progression, or in its first or second<sup>^</sup> part. Were this the case, there would be no series in existence, neither would there be any ends ; because there would be no distinctions into intermediates ; consequently no element to constitute vortices ; none to constitute ether or air; nothing to constitute fire; much less anything to constitute the innumerable parts of the mineral, vegetable, and animal kingdoms ; in a word, there would be no world. Therefore I endeavour to demonstrate that the first Finite derives its origin from



the Simple ; the second Finite from the first Finite ; the third from the second ; the fourth from the third; each being attended by a cause similar to that which exists in the primitive Simple, and which passes, by successive derivation, into the Finites. In this way I show that a series of Finites thus springs from a Simple, or from the first Finite, in succession to the fifth Finite. These five finites have a mutual relation to one another, are similar to one another, and differ only in degree and dimension, or in their relation to each other according as they are raised to successively higher powers or degrees. Again; because all Finites can become Actives, or perform gyres from a like inhering and accompanying force or cause, that is to say, from a spiral motion of the parts ; and because they can pass also into a local motion, provided there be space and nothing in it to offer any obstacle; it follows therefore that there may be a fivefold series of Actives; an Active of the first, second, third, fourth, and fifth Finite points respectively ; and at length that by means of the last or fifth Active, the fire of our system may pass into atmosphere. The same reasoning is true with regard to the compounds or elementary particles, which I hold to consist of two principles, namely, Actives and Finites; the Finites occupying the surface, the Actives occupying the interiors. And because there is thus a series of Finites and of Actives, there will also be a series of Elements such as the first or most universal Element, the second or Magnetic or Vortical Element, the third or Ethereal Element, the fourth or Aerial Element ; before the elementary kingdom with which the world is furnished has yet been fully completed. And since every single particle of each Element is elastic, encloses Actives, and possesses the faculty of passivity and activity; therefore the first Element encloses within it the Actives of the first Finite; the second, the Actives both of the first and second ; the third, the first Elementary particles ; the fourth, both the first and second

Elementary particles; the two latter Elements participating in each principle, although they enclose not real Actives but Elementary particles. For the Elementary particles are not only passive but active; they are consequently elastic, and are movable with respect to particles and volumes. The motion and mechanism of their volume depends upon the motion and mechanism of their particles ; although they are not mobile and elastic in the same degree as the enclosed first and second Elementary particles from which they receive their elasticity. Thus we show that the Elements also differ in degrees and dimensions, progressing equally with the Finites, etc., in a certain order and succession.

The series of these several subjects will be found in the work itself, as follows :—The means of attaining to a true philosophy. The first simple or first natural Point. The first Finite. The second Finite. The third Finite. The fourth Finite. The fifth Finite. The pure material Finite, or Water.

With respect to the Actives, the series is as follows :—The Active of the Point. The Active of the first Finite. The Actives of the second and third Finite. The Actives of the fourth and fifth Finite, or Fire.

With respect to the Elements, the series is as follows :—The first or most universal element. The second or Magnetic Element. The third Element, or the Ether. The fourth Element, or the Air. The fifth product similar to the Elements, or Aqueous Vapour; where we finally show, that in every drop of water is contained every single thing which had hitherto existed from the first Simple, as also the whole class of Finites, Actives, and Elementaries; consequently that in a single drop of water the whole Elementary world both visible and invisible is present.

Now since causes and things caused are similar to each other, although they differ in degree and dimension, it follows that nature is always similar to herself, and cannot

be different in the larger system or elementary kingdom from what she is in the less ; in the macrocosm from what she is in the microcosm ; in a volume from what she is in a particle ; hence the quality of the volume may be seen in the elementary particle and in the volume the quality of the particle. From this we infer that the sun consists of the Actives which first originate, or those of the first and second Finite; particularly since it is the cause of all the subsequent changes, the prime mover of things ; because other things could not have successively existed except from the first Actives, or the solar space consisting of them. Therefore that the solar vortex and the vortex of the other stars consists of the first and second, and consequently of the most universal, Elements. That the sun itself, in the formation of its vortex, being surrounded with a crust of Finites of the fourth kind, was thus the original chaos of the earth and the planets; and since this crust enclosed within it the sun, or the space consisting of the Actives of the first and second order, while the fourth Finites occasioned a pressure from without, such a chaos could resemble no other than an elementary particle ; in which, in the same way, the Actives exercise a pressure from within, while the Finites or Passives occupy the surface. It was thus by a process of the most simple kind that nature produced a chaos, from which she afterwards brought forth the earths ; being thus similar to herself in her greatest as well as her smallest productions. That consequently the earth, when just produced, and near the sun, consisted of the fourth Finites, and possessed in a larger system, like the Finite in the smaller, a motion of its parts, an axillary motion, and also a local motion ; so that in itself it was the representation of a large Finite; and as to its local and annual motion, the representation of a large Active ; that thus both in the earth and in the other planets we may see what is the quality of the Finite and what the quality of the Active in its minute

boundaries; and also in the chaos what is the quality of the elementary particle. These subjects however must be referred to in the work itself, where they are treated of under the following heads :—

The existence of the sun and the formation of the solar vortex, Part I., Chap. x.

The comparison of the starry heaven with the magnetic sphere, Part III., Chap. i.

The diversities of worlds, Chap. ii.

The universal chaos of the sun and planets, and the separation of its substance into planets and satellites, Chap. iv.

The vortex surrounding the earth, and the progression of the earth from the sun to the circle of its orbit, Chap. xi.

The paradisaical state of this earth, and the first man, Chap. xii.

In the course of these chapters it will be seen what are the velocities, periodic times, and centripetal tendencies of the planets at their respective distances from their own sun ; also what is the cause of the eccentricity of their orbits. How the earth passed through innumerable changes before it arrived at its orbit or steady course : how these changes were as innumerable as the orbits through which it passed, or as the different distances of these orbits from the sun, and its different degrees of velocity in its annual and diurnal rotation ; in a word, how every day and hour it underwent some new change from the sun itself to the course of its orbit; how it was requisite for it to undergo these countless changes, before it could be fully perfected, or be made to consist of so many series of things arising simultaneously and successively, or be enriched with so many entities as to be complete in all its kingdoms, mineral, vegetable, and animal, or could cherish seeds, unfold and expand them, and thus in so delightful and varied a manner adorn its own surface. In this state of the earth, while revolving upon its axis and rotating round the

sun more rapidly than at present ; or while, in consequence of being nearer its parent sun, it meted out shorter days and years; we show how it must have been under the influence of perpetual spring—a season most peculiarly adapted to the process of begetting and procreating; without which, no seeds could have grown, nor any vegetable or animal productions have originated.

With respect to the magnet and its forces, the reader is referred to the whole of the Second Part of our treatise ; where I attempt to demonstrate that its force arises from the motion of the first element and of the second or magnetic, out of which are formed the solar and also the planetary vortices. That its magnetism consists in effluvia, which are of such a nature as to be moveable round their own axis ; and that these, when set in a gyrating or spiral motion, act as the subtile element which we call magnetism ; consequently that from these rotations arise little vortices and connections of these vortices from one pole of the magnet or its sphere, to another pole; and that it is in this manner that magnetism arises, as also its conjunctive force when similar effluvia pervading any other body are brought near it. That the magnet itself as such, in regard to its interior texture, consists of a rectilinear or regular arrangement of its parts, extending from one polar side to the other; and that hence a sphere is formed extrinsically, connected on both sides with its axis by a mechanical necessity. That the effluvia or forementioned parts are nothing but what belongs to iron, and that iron is rendered magnetical when those parts are brought interiorly, by friction against a magnet, either into a rectilinear or any other regular position.

We show, moreover, that the declination of the magnet arises from the situation of these same particles of the first and second Element, or of the same element of which the vortices round the sun and the earth are formed; and that the magnet is directed into that same situation with its sphere in which the very particles themselves of the fore-

mentioned element are. That these elementary particles, because at the same time they create a vortex round the earth, must necessarily take a spiral course extending from one pole of the ecliptic to the other, and that hence arise the anomalies of magnetism.

See the Second Part of *The Principia* on the causes of the magnetic forces.

The attractive forces of two or more magnets.

The attractive forces of two magnets when their poles are alternated.

The attractive forces of two magnets when their axes are parallel.

The repulsive forces, when similar poles are applied to each other.

The attractive forces of the magnet and of iron.

The influence of the magnet upon heated iron.

The quantity of exhalations from the magnet, and their penetration through hard bodies.

Chemical experiments made with the magnet.

The communication of the magnetic force to iron.

The attractive force of the magnet as exercised upon several pieces of iron.

The influence of iron and the magnet upon the mariner's needle.

The various modes of rendering iron magnetic.

The declinations of the magnet as reduced by calculation.

Tables of observations of the declinations of the magnet in different places and at different times.

The causes of the declination of the magnet.

Calculations of the declination of the magnet, in different years, at London and Paris.

Tables of the declinations of the magnet at Paris, from the year 1610 to 1920.

Calculations of the declinations of the magnet at Rome, at the Cape of Good Hope, and other places.

The starry heaven, showing that it is similar to the magnetic sphere. For each is compounded of elementary particles of the same kind, especially adapted to vortical gyres, and?----- being as it were born and made mechanically for this motion.





# THE PRINCIPIA.

## PART I.

### CHAPTER I.

#### THE MEANS LEADING TO TRUE PHILOSOPHY, AND THE TRUE PHILOSOPHER.

If there is a proper connection between the mind and the organs of its senses, or in other words, if man is truly rational, he continually aspires after wisdom. The soul desires to be instructed by means of the senses, and to continually exercise its perception from them, as from something distinct from itself; while the senses desire to exercise their perception from the soul, to which they present their objects for study. Thus each performs and contributes to the same common operation, and tends to one final result, the wisdom of the man. For this purpose a continual connection exists between the soul and body; for this purpose also reason is added to the senses, and hence the desire for wisdom becomes the special mark and characteristic of man. Unless, however, he is eager to attain a knowledge which lies beyond or above his senses, he is not truly rational, nor is there a due connection between the senses and the soul. The senses and their various organs can apprehend the phenomena of their world but grossly, and in an imperfect measure. There are no animals except man which possess any knowledge beyond that acquired by the senses, and by their organs disposed in the *pia mater* of the brain. They are unable to penetrate further;

and, from want of a more subtle and active power, cannot refer the objects presented to their senses to a higher or more definite origin. But if we refer the objects, or the operations of the world upon our senses, not to the soul and its reason, but to the same origin as animals do, we are not wiser than they. The sign that we desire to be wise, is the wish to know the causes of things, as well as to investigate the secret and unknown things of nature. It is for this purpose that we consult the oracle of the rational mind, and thence await our answer; that is, we wish to acquire a deeper wisdom than that which is attained by the senses alone.

But he who wishes to reach the end, must desire also to provide the means. Now the principal means which lead to truly philosophical knowledge are three in number—experience, geometry, and the power of reasoning. First, then, let us ascertain whether, and in what manner, we have the power, by these three means, to gain knowledge *a priori*, or to reach the farthest boundaries of human wisdom with respect to natural and physical things.

By philosophy we here mean the knowledge of the mechanism of our world, or of whatever in the world is subject to the laws of geometry; or which it is possible to unfold to view by experience, assisted by geometry and reason. Under the rule of geometry are the three kingdoms, the mineral, the vegetable, and the animal, and, if it be permitted to add another, the elemental. The mineral kingdom comprehends everything in the world of a hard, material, and terrestrial kind, whether it is metallic, stony, or sulphurous, and everything else, either fixed or fluid, which cannot be described as vegetable or elementary. The vegetable kingdom comprehends everything which springs out of the mineral kingdom, and which adorns the surface of the earth by its growth and vegetation. The animal kingdom comprehends whatever depends for growth upon the vegetable kingdom, but which lives in virtue of possessing some kind

of soul. The elementary kingdom comprehends all those substances which are fluid of themselves and by their own nature, every particle rejoicing in and thriving by its own peculiar motion and elasticity. A group of these constitutes an element, such as air, or ether, or others still more subtle, which we shall hereafter investigate in the course of our *Principia*.

Under the empire of geometry, and under the mechanical laws of motion, we place the whole mineral as well as the vegetable kingdom, and indeed the animal also with respect to mechanical organs, muscles, fibres, and membranes; or with respect to its anatomical, vegetative, and organic relations. But with respect to the soul and its various faculties, I do not think it possible that they can be explained or comprehended by any of the laws of motion known to us ; such indeed is our present state of ignorance, that we know not whether the motions by which the soul operates on the organs of the body are such as to be reducible to any rule or law, either similar or dissimilar to those of our mechanics. The elements by which the earth is surrounded, and in which it floats, acknowledge mechanism and its laws to be as it were peculiarly their own ; so intimately is mechanism associated with the elements, that it owes its very existence to them; and indeed the method by which they are set in motion and actuated, is mechanism itself, which is thus both conceived and born of the elementary kingdom. Since then the elements called air, ether, as well as others of a still more subtle nature, are naturally and peculiarly subject to geometry and mechanism, we can explain them by the assistance of experience, the known laws of motion, and geometry. In this first division of our *Principia* we treat, in part generally, and in part specifically, of the elements; of their origin from the first and most subtle, to the last which surrounds the earth; also of the motion of the elementary particles, their form, and the rest of their properties or essentials of their nature.

It is an arduous attempt to explain philosophically the hitherto secret operations of elementary nature, far removed as they are, and almost hidden from the perception of our senses, and to place, as it were, before the eyes those things which nature herself seems to have withdrawn from view and of which she has denied us knowledge. In this ocean I would not venture to spread my sail, without having experience and geometry continually present to guide my hand and control the helm. With these to assist and direct me, I think I shall be safe in approaching and voyaging over this ocean. For geometry and experience are, as it were, the twin stars by which one's way may be directed, or which show the way by their light; for of these it is that we stand most in need amid the thick darkness which envelops both elementary nature and the human mind.

1. By experience we mean the knowledge of everything in the world of nature which is capable of being received by the senses. This definition embraces everything, whether in the elementary kingdom, or in metallurgy, chemistry, botany, anatomy, etc., in so far as we can ascertain the manner in which it affects the senses or acts *a posteriori*. These things may indeed be termed objects of the senses and phenomena, drawn from the great storehouses of natural things.

Let it not, however, be imagined that any experience, or this knowledge derived *a posteriori*, and confined only to one man, or even to one age, is sufficient for the purpose of exploring the hidden paths of nature. To crown the investigation with success, we require the experience of many ages; from one age to another experience will increase, till we have such a store of information as will supply us with phenomena and experiments calculated to explain any part or any series of the operations of nature.

The sciences, which have now for about a thousand years been adding to our experience, may at this day be said to have so far advanced, that the enquiry into the secret and invisible things of nature need be deferred no longer. For

•an infinite number of phenomena is already known, capable of leading us up to this point; and besides, the writings of so many ages are extant, which will sufficiently aid us in an *a priori* investigation, and deduction from the first principles of things. With respect to elementaries we have an ample wealth of experiments in regard to the ether, air, fire, water, and the magnet; and if we reckon those also which have been made in metallurgy and chemistry, where nearly all the elements are called forth, and used for the solution and condensation of bodies, we think that the world is at this day sufficiently instructed for our purpose.

In fact, there is no need for that innumerable variety of phenomena which some deem necessary, in order to acquire a knowledge of natural things. We require to make use of the more important only, such as bear directly and immediately upon the point, and whose reference to our mechanical world and its powers is not too remote. For by them we may be led first to complex, and to us, general principles; thence by means of geometry, and aided by the leading phenomena which lie intermediately between the two, we proceed to particulars; then, by a chain of connection, to the more simple ; and thus at last to the most simple, to the fountain-head, in proceeding from which they have gradually become more and more modified. The remaining mass of experiments, which are either farther removed from the first source, and thus from the first and simple mechanism of the world, or which are merely collateral, and not in the same direct line of descent, are not so essential; indeed, they would tend rather to divert the mind into a different course, than lead it onward in the great high road of our investigation. The reason is that there is a countless variety of phenomena that are very remote from their origin, and which reveal no path leading to it but through manifold intricacies and mazes. Nature, branching out into such varieties of modification in our world, may be compared to the arteries and veins of the animal body; these, when

nearest to their common fountain, the heart, have considerable-breadth and magnitude ; but become divided in their course into smaller and smaller ramifications, and finally into the very smallest, and even into ramifications which are like invisible filaments and capillaries. If you are ignorant of the fountain-head and origin of the blood which flows through these arteries and veins, and yet wish to explore it by means of experiments, you would scarcely commence with the smaller capillary vessels, and there make many dissections, so as in the mind to trace them from one branch to another. In so laborious a pursuit you would most probably be diverted from your track into other arteries and veins, and thus remain long perplexed and misled by their numberless intricacies before you could reach the great and regal aorta. Nay, by such a plan, a still further source of error, and consequent removal from the heart, might arise in the section through arteries into veins, while aiming at the contrary direction. Nature may be also likened to a labyrinth; if you are in this labyrinth, the attempt to wander through all its windings, and to take note of all their directions would be fruitless; for in this case the puzzle would only grow the more inextricable, you would only pursue your footsteps in a circle, and when most elated by the prospect of emerging, come to the selfsame spot. And so if you would reach with ease, and possibly by the shortest road, the exit of the labyrinth, you must reject the senseless wish of exploring all its intricacies; rather planting yourself at some intersection of its paths, strive to ascertain somewhat of its general figure from the circuitous route you have already trodden, and retrace, if advisable, some of your steps. Thus may you easily ascertain the way leading to its outlet, and there obtain the clue to direct you through all its mazes ; and when you have familiarised yourself with their plan, you may throw aside even the clue itself, and fearlessly wander about in the labyrinth without it. Then, as if seated on an eminence, and at a

glance surveying the whole labyrinth which lies before you, how will you smile in tracing the various windings which had baffled your judgment by manifold and illusive intersections ! But let us return to actual phenomena, and leaving similitudes pass on to the subject itself. By too great an accumulation of phenomena, and especially of those which are very remote from their cause, you not only defeat the desire of laying open the hidden operations of nature, but plunge yourself more and more deeply into a maze, where you are perpetually drawn aside from the end in view, and misled into a contrary region. For it is possible that many things of seemingly opposite natures may exist from one and the same origin; from the same first cause exist fire and water which are contrary to each other, and likewise air, which absorbs them both. Thus we are confused by their contrary and heterogeneous natures, and by their endless variety, and we may form a very diffuse and indistinct notion. After the experience of so many thousands of years, if a person should be importunate, and desire still further knowledge, confessing that in these respects he is still needy and ignorant, it is no wonder that he should be unable to arrive at the knowledge of mundane things so as to reason from principles and causes; for were he possessed of the greatest possible accumulation of facts, they would only serve to increase the difficulty of attaining his end.

In the state of ignorance  $y$ , in which we are at the present day, we gain knowledge only through experience; not merely our own individual experience and that of our own age, but the experience of the whole learned world and of many ages. When we have learned from our teachers what the learned world has discovered, we are individually enabled to add new experience of our own, and thus continually to become more enlightened. I affirm, therefore, that at this day we are made wise only by means of experience; nor can we arrive at wisdom by any other path. It is impossible to receive

knowledge immediately from the soul; man attains it only through the medium of organs and senses. The first fountain of knowledge springs from these, and it is by means of the connection existing between them, and the faculties of reason and judgment, that we acquire a perception of objects ; that is to say, it is only by means of experience acquired by organs, and transmitted to the mind, that we can become wise. The means, therefore, of all our wisdom is to be found in experience ; without this the human race would be barbarous, merely animal, and irrational. Suppose a person, destitute of education, left wholly to himself with wild beasts and apes, or advancing to manhood without the society of any animal—What kind of brute would he be ? What intelligence would he enjoy from nature ? What would be the operation of his higher aura, or mind, on the organs of his body ; or, at a riper age, what would be the operation of the organs of his body on his mind ? Man is made and formed, and distinguished from the brutes, solely by education; in the process of which the organs, which are intermediary between the mind and the body, being brought into exercise, are, as it were, cultivated and fashioned ; and exercise so arranges the elements enclosed in the small membranes and organs, as to enable the most subtle tremors and motions to pass and repass throughout them, and opens, as it were, those secret and intricate avenues which lead to the most subtle and active entity of our nature. It is by means of this that the oracles of the rational mind are disclosed. From experience we have received all our sciences. By experience we know how to discharge the duties of a citizen, and to live with others in moral society; we learn to be prudent; we learn to be philosophers. By experience we acquire the arts of war and of constructing fortifications ; we learn to train soldiers so that each individual of himself, conjointly with the battalion, and the battalion with each individual, is enabled to stand securely against the attack of the enemy. We learn by experience to construct ships, to build houses, to cultivate fields and gardens ; arts which were first



-conceived from experience, and thereafter practised, attained perfection in later ages. Let us instance the sciences of metallurgy and chemistry. Metallurgy, which commenced in experimental knowledge many ages before the flood, continued its progress until it attained the excellence it now possesses; so that we now fully understand how the hardest rocks can be penetrated ; how shafts of different kinds can be driven even through mountains, passages bored to the bowels of the earth, and its metallic veins opened and explored ; how laboratories and furnaces should be constructed for the purpose of extracting and smelting the better part of the ore, and how the metal is afterwards to be made into bars and shaped ; with many other particulars which relate to the hidden course of the vein, and the formation of the metal itself. These discoveries are all owing to that great instructress experience, who seems to have been the more ingenious in regard to this art, and the more desirous of learning it, because it produces silver and gold ; to which means all things are obedient which procure livelihood and honours, and which, upon that account, so intensely interest mankind. From experience we learn the vast science of chemistry, or the art of decomposing ores and of separating metals, and all the constituents of vegetable nature, by both the dry, and the wet method, as it is called ; how sulphur, spirits, oils, and liquids of various kinds, may be produced by means of fire or a solvent; how the lighter parts, and likewise the heavier, and metallic substances, dissolved by the solvent, may be separated in the liquid itself, and made to sink to the bottom, or ascend to the surface; how flame and fire are to be controlled, and to what degree of heat a body which can be reduced by it should be subjected; or how a slow fire wastes bodies, or a stronger and fiercer one descends deeper into their structure, penetrates into their inmost and hidden things, and divides and separates them into parts. But this entire science is the offspring of experiment. We are indebted to experience therefore for all our knowledge, while

experience itself is indebted to the senses, by means of which objects are subjected to the rational activity of the mind, and thus we are finally enabled to acquire wisdom. In proportion, therefore, as the sources of experience are the more abundant, and the better disposed and distributed throughout the organs; in proportion as the intermediary organs are more exact in their harmony, and better adapted in their form; and in proportion as a more elevated path is thrown open to the most subtle principles of things by series and continuity, in the same proportion man may become wiser. But, after all, alas! what is' our wisdom —truly such as what is finite is to what is infinite ; and in respect, therefore, to the wisdom of the Infinite, nothing.

The reason why we must acquire knowledge by means of experience, and investigate the nature of objects and set them in a distinct point of view, by subjecting them to the operation of the reasoning faculty, is, that we have an active and most subtle principle and soul, to which phenomena can be submitted; whereby we are enabled, through the comparison and series of many phenomena, to form a judgment respecting them; and, by considering their uniformities, similarities, analogies, and analyses, to discover their causes by geometrical and rational investigation. Man is distinguished from brutes by reason alone; in other respects we are mere animals and organized forms. We have senses like those of brutes, and we have an interior structure not unlike theirs : our sole distinction consists in that invisible or reasoning faculty, that more subtle active principle, to which we can more inwardly refer objects, and consequently perceive them more distinctly. It cannot be denied that there is a connection between the organs of the senses and the soul, and that the motions of the organs of the senses can be in a moment transmitted to the soul by means of that connection; it is equally certain that those motions thus pass out of a grosser medium into a more subtle one, and that these media are in contact and succeed one another in order. For if the-

motions impressed on the organs are instantly perceived in the soul, and if the organs of the senses are of a grosser substance than the soul, it follows, that all perception passes out of a grosser into a more refined medium, by means of a connection and of a contiguity existing between them, and thus arrives at that most active principle which is the primary and ultimate constituent of man. We can form no idea of this perception in the soul, but by comparing it with the elements. For there exists a primary and a most subtle element, and others that are successively more gross; thus there are air, ether, and others. If the particles of a grosser element should by any means be disturbed, either individually or collectively, so as to experience either an undulation, or a tremulation, or any other kind of movement, such movement would pass out of this grosser medium into the more subtle one. If these media were in such close contiguity and connection as to form together one volume, then the motion arising in the grosser element or medium would be more sensibly felt in the more subtle one. The tremulation of one particle, or of its surface, in the grosser medium, might cause a kind of undulation among the particles, or in the volume, of the more subtle medium : and if media and elements of a still more subtle nature were present and intermixed, the same motion which was tremulous in the first might be undulatory in the second, and cause a local motion among the particles of the third. Therefore, when a motion passes from a grosser medium into one that is more subtle, it becomes successively more sensible; and if more sensible, then more distinct. We are distinguished therefore from brutes by this, that their perceptions do not penetrate to so subtle a medium as they do in man, but that they stop as it were midway, where perception is not so acute and less distinct. Let us suppose the organs of the senses to be mechanical, and formed according to the mechanism of the motions existing in the elements; let us suppose that there are membranes which are acted upon by waves of the air, or the ether; let us suppose also that these membranes are of

different kinds, either grosser or more subtle; let there be a hard covering, a soft one, and one still more subtle; for we see that all things, both in the vegetable and animal kingdom, go out into ramifications, which become more and more subtle till they arrive at the highest degree of tenuity, as is the case with the muscles, the nerves, the veins, and the membranes. If, therefore, a motion arises in a grosser membrane, and passes into one that is more subtle, the effect will be exactly the same as in passing from a grosser into a more subtle medium. If the media or membranes be so contiguous and in such mutual connection, that a motion impressed on that which is grosser can be instantly perceived in that which is more subtle, then the least motion in the grosser becomes greater and of a higher order, in the more subtle, and consequently more easily perceived and distinct. That the membranes perceive, is a very common form of speech among anatomists. But let us leave these subjects, from which we only mean to infer that we ought to be instructed by the senses, and that it is only by means of the experience conveyed from them to the mind that we are able to acquire knowledge and thus become wise.

I have observed, that man is perfected by exercise, and that the organs which are intermediary between the senses and the mind are formed by constant cultivation, and that without cultivation and exercise those organs would be closed, as it were, and consequently man would be like a brute. The very slowness of his progress from infancy to manhood, contributes in a very fundamental and essential manner to the forming and opening of such organs or motions in the most subtle membranes; not to mention the construction of the brain itself. For we do not arrive at adolescence till after fifteen or twenty years, or more; whilst the larger, stronger, and more muscular animals, arrive at maturity in between three and five years. In the meantime, our organs are yielding and soft, like wax, and are thus enabled to receive the natural and simple

motion of the elementary world, and to accommodate it to themselves in a gradual and orderly manner ; so that whilst they consolidate, the traces and elements, or forms and changes, of the motions they are exposed to, can be fashioned within them. The reason is that, while the parts are being adjusted to one another and increasing in size, they grow hard by degrees. If, therefore, during this interval, the parts which as yet are weak, tender, and easily affected, are agitated by perpetual and long-continued motions, their tender texture, being thus constantly in motion and agitation for a long time and always acquiring form during its growth and expansion, is rendered very pliant and impressionable to the innumerable different motions of this description. But on the other hand, if an animal arrives sooner at maturity, and its parts are fixed very quickly with respect to one another before they are accustomed to such motions, they must be rendered more rigid, and become in a manner hardened; and so the more subtle parts, and those which are nearer to the most simple, afterwards yield with difficulty to the motions impressed, and afford no passage through themselves but what is gross and obscure, just as if the impressed motion had to pass through a thick covering ; for the greater rigidity and thickness of the coverings of the organs and membranes renders them less compliant to subtle tremors. The longer, therefore, an animal is in arriving at maturity and the full tension of its parts, the more open will the passage to its most subtle organs become, the thinner will be the coverings of its membranes and parts, the more compliant to the motions impressed on them, and the more numerous the ramifications into which it will extend; consequently, the more perfect will the animal become, provided the means which can perfect him are employed; which consist, as was before said, in perpetually calling his faculties into use, cultivation, and motion, by means of education.

Now, although we acquire wisdom by experience alone,

it does not, therefore, follow that they are the wisest who are the most experienced, or who retain a great deal in their memory ; I affirm only, that they are capable of becoming wise, and that experience is the means which leads to wisdom. For experience, considered merely by itself, is knowledge, and not wisdom; it is only the threshold and entrance by which wisdom may be approached. He who has knowledge, and is merely skilled in experiment, has taken only the first step to wisdom ; for he only knows what is posterior, and is ignorant of what is prior; thus his wisdom does not extend beyond the organs of the senses, and is unconnected with reason. He who desires to be wise is wise from both. In the state of ignorance in which we live, experience is a kind of phantom, a mere counterfeit which appears like wisdom. At this day they are reputed the wisest who have the greatest experience; by making a display of it they are immediately regarded as persons of acute judgment and refined perception; and the more so, if they have eloquence and their words are well chosen and arranged; still more so, if they know how to captivate the ears of their auditors by sweetness and melody of voice and accent. But those alone arrive at the goal of true wisdom who not only possess a very great store of experience, but have also their organs so formed and disposed, from the senses even to the soul, by means of exercise, and so well and closely connected and arranged, that whenever required, they can adduce from their treasures of experience such instances, and such only, as are suited to the immediate purpose; by the similitude, analysis, and comparison of which they are enabled to reason clearly, and by a chain of argument to arrive even at the causes of the subject of enquiry, or at the things antecedent and prior to it. But experience taken by itself, as I have said before, is not wisdom. A painter who possesses colours and dyes, and can draw lines with them, is not, therefore, master of his art; nor is a manufacturer of instruments capable, on

that account, of skilfully touching the strings of a harp and producing harmony. He who possesses a large library of books is not necessarily a man of learning, nor does he for that reason, deserve the laurel, for his wit may probably be very gross and very dull. Or, if we consider the matter more closely and interiorly, the historian who has turned over a multitude of books, and has learnt from them the fates and vicissitudes of the ages, and the lives and exploits of all the heroes, is not on that account wise, and worthy of being raised to official eminence; that is, he is not, from that fact alone, an able member of the commonwealth, and more deserving than others to be seated at the helm. He ought to have the events and exploits of former times so arranged, by means of his organs and the various chambers of his memory, as to be able, on every occasion, to refer to such historical circumstances as most resemble and are analogous to the case in hand ; and these, as if spontaneously, and no others, ought to present themselves to his reasoning powers. Nor is he even then wise, unless he has previously penetrated, by rational philosophy, into causes and principles; so that he may afterwards be able to argue upon the present circumstances from causes and principles, or from reason and *a priori*, and to form more certain conclusions by a chain of inferences; and, having his counsels derived from such a source, may be able, by the timely adoption of proper measures, to provide for the welfare of the State.

It, therefore, follows, that he who retains all the natural experience of the world laid up in the storehouse of memory, is not on that account a philosopher, and capable of knowing the causes of things, and of reasoning *a priori* ; for to do this, he must know how to digest all things analytically by means of geometry and rational philosophy, and must possess the faculty of reasoning philosophically, which consists in a certain arrangement and form of the organs, as connected with the rational faculty, produced by continual cultivation and

use. It is thus that a man may first become a philosopher, and penetrate into the causes of things, and afterwards from causes speak by means of experience.

Hitherto we have treated of the first medium leading to philosophical wisdom, or the knowledge of the mechanical or organic world; we now proceed to the next.

2. The second means leading to wisdom, by which the secrets of invisible nature may be unlocked and revealed, is geometry and rational philosophy ; by means of which we are enabled to compare our experiments, to set them in order analytically, to reduce them to laws, rules, and analogies, and thence to elicit some third or fourth thing which was unknown before. Experience alone cannot unfold or disclose anything, and reduce it to its more simple parts ; it cannot so arrange facts that resemble one another as to discover what was unknown by observing its similarity to what is known ; for this is the office of reason. But to retain many things in the memory, and afterwards to form theories or conclusions respecting things unknown from their resemblances and analogies to such as are known, and thus to speak from a chain of experiments, is a method of attaining wisdom at once familiar and natural.

The whole world itself, elementary, mineral, and vegetable, and also the animal kingdom, as to its anatomical organisation, is a pure system of mechanism. The science of mechanics itself with all its powers, geometry with all its figures and quantities, and philosophy with its resources of reasoning sprang solely from the elementary world ; they are the offspring of the elements of which they were conceived and born. The science of mechanics is the law of nature herself as she acts and moves in the elements ; and it is according to this that her parts have their motion both in the simple and compound. Without the elements and their regular disposition and motion, no mechanism could exist. As, therefore, the science of mechanics is the law of elementary nature, it cannot be denied that the world itself is suitably



governed by its laws and rules, and that the whole is a mechanism ; a fact which becomes the more evident when we observe that nothing can be in a state of motion without obeying some mechanical law. If motion is supposed, both the figure of that motion must be supposed, and also its space; consequently, if there are figure and space, as well as motion, the whole is mechanical, and is subject to geometrical laws. The very attributes of motion, figure and space, because they cleave to it, are geometrical. However small a body may be, it is geometrical, because it possesses figure and quantity according to its own dimensions. It may also be considered as subject to the laws of proportion in itself, because there is distance between its limits, and between one point of that distance and another there is proportion. The case is the same in other instances. Thus not only motion, but every finite thing in a state of rest possesses attributes which are purely geometrical. Geometry, therefore, accompanies the world from its first origin, or first boundary, to its last, and is inseparable from it; so also do the principles of mechanics, though they might be different in a world differently formed, and in elements differently formed and arranged; and thus, although there may be innumerable worlds, nothing can exist in any finite world which does not depend upon some mechanical principle, and a similar principle of geometry must be common to them all. Whoever supposes the world to be constituted in any other way, must take refuge in occult qualities, that he may conceal his ignorance and preserve his reputation as a philosopher in the learned world. He whose mind is well formed cannot deny that the world is composed of elements; that elements are composed of particles; that particles are composed of spaces and forms; that particles of definite form are the result of motion, and of situation suited to such motion; and that motion and situation have their proportions.

As all things in the world which possess motion and limits, are mechanical, it also follows that the smallest natural things,

as well as the largest<sup>^</sup> flow in a mechanical order, and that the smallest and largest are governed by similar mechanical principles. And though the particles of the elements are invisible, and in a great measure elude the observation of our senses, yet, as they are fluent and bounded, they are geometrical, and must flow and subsist in a mechanical manner. The case must be the same both with the objects that are within, and with those that are beyond, the sphere of our vision. That the equilibrium and motion of the greater bodies follow the common and known laws of mechanics, is clear from the case of the very greatest. We see it to be the case in the vortex of our sun, in the planets, in the earth, in the satellites that revolve within the boundaries of the greater vortex and move elliptically through their proper orbits with perfect regularity, exactly as would smaller bodies if they were made to revolve in a similar orbit. These immense masses are governed by the same law, or the same centripetal and centrifugal tendency, as is observable in small bodies that are made in like manner to revolve round their centre. A similar proof is afforded by the animal kingdom also ; in the case of whales, elephants, and other animals ; tendons, nerves, muscles, and fibres are observed to move the feet, arms, fingers, and the rest of the organs of the whole body. In certain animals we see the blood and fluids flow and return through the large and small arteries and veins, and by their proper ducts and vessels ; and either, as in plants, proceed to certain fixed boundaries, or continually retrace their steps. We also see how the lungs perform their alternate movements, like a pair of bellows, according to the inspiration and expiration of the air. That all these motions are mechanical, our eyes are witnesses, for the nerves, fibres and muscles, all properly formed and adapted to the respective movements, lie open to view ; whence we are enabled to investigate these mechanical and hydraulic machines themselves, to handle, as it were, these original motive powers, and to demonstrate that they all depend upon mechanical principles.

The same observation is true of the organs of the senses. For it is known that the undulating air flows into the ear, and occasions in its covering or tympanum a motion imitative of itself; that it afterwards continues the same motion throughout its malleus, incus, cochlea, and channels and instruments of sound, toward the interior parts ; so that the undulation of the air seems to have formed such a mechanism of its own, that it may be received and transmitted farther toward membranes of the same kind lying within for the reception of sensation. What a wonderful mechanism is to be seen in the eye, where there are so many coverings, so many humours and little fibrils, so many nerves leading from them towards the interior parts—by means of which whatever is received from the ether in the eye, insinuates and propagates itself therefrom in a mechanical way towards coverings of the same kind in the meninges, and thus more and more deeply : so that the ether seems to have formed in the eye a mechanism of its own, by which its undulations can be received, and be farther transferred toward the interior parts, till sensation is experienced. These contrivances and minute machines, most exactly formed, according to the laws of mechanics, for the reception of the modes of motion of the air and ether, we can view, examine, and investigate in all their parts, and see their very membranes and coverings extended, as it were, from the interior of the head to the light of day, in order that the elements may be able to act immediately upon them, and more speedily convey the impressed motions thence towards the interiors, by first gradually affecting the coverings of the same kind, and then such as are smaller and more sensitive.

From these observations we may conclude that the animal body is governed by mechanical law, and, as will now be demonstrated, that the same kind of mechanism is found in the smallest animal as in the largest. For there are animalculæ so small as to escape the observation of the keenest eye, and to be discoverable only by the aid of lenses and glasses of very

small aperture : yet these, diminutive as they are and beyond the limits of our vision, have feet, legs, and other members,, which are moved in the same manner as those of great whales and elephants ; they have lungs which inhale and exhale the air; they have a heart which sends some kind of blood through their little frames ; they have sight, and probably hearing, consequently they have coverings and membranes,, which are extended and expanded from within the head toward the eye and ear till they come in contact with the element itself; they have humours, fibres, and vessels receptive of the motions of the elements, by which those motions-are transferred toward the coverings and membranes that are contained within this little animated point; they have also their desires, pleasures, gratifications, loves, parturitions, and the emotions of their animal spirits. Now as there is the same and equally ingenious mechanism in the smallest animal body as in the greatest; and as the former seems, on account of the more subtle texture of its membranes, to possess quicker and more perfect motions than those whose bodies are grosser (for the smaller animalculae are in a manner nearer to the more subtle and simple elements) ; what other conclusion can be drawn than that nature is the same, is like herself, and is governed by similar mechanical laws in the-smallest finite things as in the greatest ? Thus also in respect, to the elements ; if they have motion it must be by means-of particles, consequently they must be made up of particles ; and the particles of one element must have the particles of another element within it and without it, with which it must be in contact and in equilibrium. But this will be explained in the course of the work; I only wish to state here, that in these invisible and very small elementary things there is the same kind of mechanism as in the greatest; that it is the same in whales and the smallest insects, in a vast world and a little revolving globe.

If geometry is considered, it will be found to be always like itself. For if there is space, it is always accompanied

by form; if there is motion, form too is always inseparable from it; if several spaces and forms are imagined, there will always be a ratio between those spaces and forms; there is the same ratio between the greatest numbers as between the smallest; as for example, there is the same between 100,000,000,000,000 and 500,000,000,000,000

•as there is between 100,000,000,000,000 and 100,000,000,000,000\* The case

is the same with the differences in the infinitesimal or differential calculus; that is, there is the same ratio

between  $(dx)$  and  $(dy)$  as there is between the integers themselves (tc) and  $(3/)$ , though  $(dx)$  and  $(dy)$  are differences nearly equal to nothing. Thus also in hidden nature, or the smallest corpuscular existences, the relative motions among the smallest elementary particles cannot differ from those

among the greatest masses in the same configuration, unless there are present other bodies outside which can

•cause some dissimilarity. It is only that which is not finited or bounded that is outside the laws of geometry; but as soon as anything is limited by boundaries or motion, or both, it is immediately connected with form and space, and comes under the empire and control of geometry, which has for its subject whatever has boundary or form. The mechanism of minute things is better, purer, and more conformable to rule, than that of things which are large and intricately compounded. For in minute things the weight, circumference, surface, and form are less; their modification, which is the cause of change, is less; and consequently there are less dissimilitude, fewer points of contact, and less friction; thus in minute things there is nothing to prevent the whole from being geometrically put in motion—a circumstance which cannot be hoped for in great bodies, for the reasons just mentioned.

As nature operates in the world in a mechanical manner, and the phenomena which she exhibits to our senses are subject to their proper laws and rules, it follows, that nature •cannot thus operate except by means of contiguity and con-

nection. Thus the mechanism of the world consists in contiguity, without which neither the world nor its mechanism could exist. Unless one particle were to act both upon another and by means of another, or the whole mass, by all its particles, were to act as a unit, and at the same time at a distance, nothing elementary, capable of affecting or striking the least organ of sense, could exist. Every operation takes place by contiguity. Without a perpetual connection between the end and the means, there would be no elementary nature, and no vegetable and animal natures thence originating. The connection between ends and means forms the very life and essence of nature. For nothing can originate from itself; it must originate from some other thing; hence there must be a certain contiguity and connection in the existence of natural things; that is, all things, in regard to their existence, must follow one another in successive order. Thus all things in the world depend for their existence on one another, since there is a connection, by media, from ultimate to ultimate, whence all things have respect to their first source from which they exist. For if all things had not respect to their first source, but only to some intermediate link, this intermediate would be their ultimate: but an intermediate cannot exist but from something prior to itself, and whatever exists from something prior to itself cannot be the ultimate, but only an intermediate; for if it were the ultimate, the world would stop short at this ultimate and perish, because it would have no connection with its proper ultimate by something antecedent. These remarks have reference to the subject of existence. With respect to the subject of contingencies, or modes and modifications, which exist both from ultimate, simple, and intermediate substances, these must be continuous and mutually connected, depending successively on one another from one end to the other. Thus must all things, both those which are essential and those which are incidental, necessarily have a connection with

their first substantial principle ; for they proceed solely from simple or compound substances; and as these substances depend for their existence upon one another, it follows that the modifications related to those substances must be dependent on the same connection.

We see then that there is contiguity in all things, and that nature produces them by means of the connection from one end to the other, of both substances and causes. Whatever is first produced by such connection must continue to subsist by the same means. We see in plants that there is a connection between the root itself and all the extremities, and every least part of the extremities; that there is a connection between the intermediate stem and the little twigs and leaves, by infinite filaments stretching from one shoot, branch, and stalk, into another, and thus affording hidden ways and passages for the continual reception of nourishment. It is in such contiguity that vegetation itself consists ; and the life of the plant afterwards continues in the same contiguity and connection ; the part where it ceases no longer grows, but withers and dies, and drops useless from its stem.

The case is the same in animals ; parts cover over parts, and grow<sup>7</sup> by contiguity. Both the nervous and membranous system is coherent and contiguous. There is no part in the whole animal to which the fibres, muscles, veins, and arteries do not extend ; no fibre, that is not derived and ramified from some larger nerve ; no nerve, that does not proceed from the medulla spinalis or oblongata and its coverings ; and no vein, but what originates from that great one which flows immediately from the heart. The medulla and its coverings, with which the nerves are connected, are in contiguity with the very membranes of the whole brain; its grosser coverings are contiguous to its more subtile ones; the dura mater to the pia mater; the pia mater to the more subtile parts; and thus the contiguity is continued till it arrives at those simple active substances, from which all motions or affections can

afterwards reflect and expand themselves to the most subtle principles of all. It is, therefore, manifest that there is a continual connection of the whole body with its minutest parts. If the connection with any part were broken, that part would no longer partake of the life of the rest of the body, but would die, having lost its contiguity. If a connecting part, mediating between the grosser and more subtle motions of the body, were to be broken, something like death would seize that part. Hence also the poets have compared the life and fates of man to a continuous thread woven by the Fates, and they feigned that if this thread were anywhere severed, his life would also be cut off and all the series of his destinies.

But to return to our elementary world. If we admit contiguity, we immediately have causes for every occurrence ; but if there be no contiguity, nothing can occur in the world, because there is no cause for its happening either in one manner or in another. The cause and reason of all effects and phenomena is to be found in contiguity and connection. If this principle of contiguity of nature were to begin to be diminished and fail, the world, as to the phenomena existing in it, would fail and pant as it were for breath, and be reduced to its last extremity. Thus all things depend on something contiguous to them, as the body depends on life, hearing on the air, sight on the ether. The equilibrium of all things in the elements depends also on contiguity. The air itself could not undergo and communicate pressure according to its altitude, nor could it force up the mercury in the barometer to indicate the approaching weather, unless its particles were contiguous to, and rested upon one another, and unless the pressure and weight of its lowest particles, or those nearest the earth, were balanced by those which are above the clouds; neither could any particle of air expand itself, nor could there be so exact a proportion between the degree of its expansion and the superincumbent weight, without the contiguity, continuous action, and consequently equal pressure,



of the surrounding particles. Nor could the air vibrate so distinctly and harmoniously, and actuate the drum of the ear in a manner conformable to itself, and operate as it does in every direction, unless there were contiguity. Without the existence, from the sun to our globe and to the eye, of more subtle elements, the particles of which are contiguous to one another, the eyes could not behold the sun; there would be no light, and no sight or perception of light; but as the eye sees and perceives objects at a distance, it is clear that there is a contiguity between itself and the sun, the stars, and the planets. In short, no reason can be assigned for any phenomenon, unless we admit contiguity or connection ; for no phenomenon can exist, except in something contiguous. The conclusion, therefore, is, that the mechanical world depends upon contiguity and connection.

That there is a connection and contiguity in the elements, appears also in men and animals, who are constituted, and in a manner formed, according to that connection and contiguity of the elements. In some, the connection of things existing in the elements appears to be natural, for all the harmony in the elements answers to the connection of their organs, and so a corresponding harmony is felt in their organs without any assistance from rules : for to some men and animals the mechanism of the world is natural, or is familiar to them by nature without any other instructor. Thus we find the hearing delighted by harmonious sounds and the concordant vibration of musical strings. Musical harmony has itself also its own rules and its own geometry : but we have no need to learn this ; we have it in the ear itself and the organs of hearing, which are in harmonious coherence. We are exhilarated, affected, entranced by harmonious and concordant sounds ; but discordant sounds give us pain. For sound when harmonious, glides on into the soul as it were spontaneously by means of the connection between the two, and with an even stream ; but when it is discordant, the connection is immedi-

ately disturbed and distorted, and the sound does not arrive at the soul without giving pain. It is from the same cause that some persons are musicians by nature, and know immediately how to accompany their voice with an instrument, or an instrument with their voice, without a master; although music, like all other things in the world, has its own geometrical rules and proportions. The eye, also, can feel whether a thing be harmoniously formed or not; if it is, and its mechanism is well arranged, the soul is immediately delighted through the eye. Thus the eye discerns whether a tree is growing and flourishing in a manner to give us a sense of beauty and delight; whether the ornaments of a garden conform to the rules of art; whether certain mixtures of colours harmonize well; whether an edifice with its parts is constructed according to rule ; whether anything is beautiful and, therefore, delightful; whether the face of a man or of a virgin is finely formed or not : and all this it does without knowing the rules in conformity with which beauty consists; although, nevertheless, beauty has its proper rules, and consists in a conformity and harmony of parts. As, too, there is a like connection and harmony between the eye and the mind, therefore whatever is harmonious immediately flows, with even course, to the mind, which it exhilarates and expands; while all things that are distorted, and not in conformity, occasion it a certain violence.

We have still more striking tokens of harmony in the other senses, as in the smell and taste, by which latter sense alone we can discover whether the parts of a substance be angular or round, or what is their form and figure. The mechanism,, therefore, of some things is natural to our senses. As brute animals also are formed according to the connection of the world and its elements, so also the organs of their senses are in like manner endowed with a connection and harmony similar to that of the elementary world itself; hence there are indications, in many of them, of a certain natural mechanism. We see the spider construct her webs in a geometrical manner,

drawing radii from a centre, and binding them together in polygons and circles ; and she places herself in the middle, and lies in ambush for her prey. We see the beaver build himself a house, neatly fitting one beam to another; exactly like an architect who proceeds by geometrical principles and rules. We see birds build their nests, in various ways, of boughs, straw, reeds, earth, and clay, so that it would be scarcely possible to build them better by the rules of art. They know how to give a round form to their nest, to attach it to the eaves of buildings or boughs of trees, to contrive supports for it, and to unite together its parts so as to leave in the middle a cavity lined with chaff or feathers, within which in soft repose they may lay their eggs, and pass the period of incubation. Bees form for themselves hexagonal cells of wax; and there are numberless other instances. These instances may suffice to point out and confirm the existence of a natural mechanism ; for the senses are formed in accordance with the mechanism of the elementary world, and everything is in agreement with the senses which suits the continuity of their structure.

But though the world is mechanical and composed of a series of finite things which originate by means of the most varied contingents ; and though the world, being of such a nature, may, with the aid of geometry, be explored by means of experiment and its phenomena; it does not, therefore, follow that all things in the world are subject to the government of geometry. For there are innumerable things that are not mechanical, nor even geometrical; such as the Infinite, and whatever is in the Infinite. Geometry treats only of finite and limited things and of the forms and spaces originating from these, together with their several dimensions; but that which is Infinite is beyond and above the sphere of geometry, being regarded by it as its origin and first beginning. For the finite recognises that its origin is in the Infinite. Without the Infinite the finite could neither arise nor subsequently subsist; and to this every finite refers itself, even geometry

also. Geometry, therefore, is itself subservient to that most vast Infinite, from which as from their fountain-head such an infinite number of finite things emanate, and owns that there is nothing in itself either similar or analogous to it. There is then an Infinite, which can by no means be geometrically explored, because its existence is prior to geometry, as being its cause. There are also many other things, the nature of which, though they originated from the Infinite, and began to exist together with the world, has not yet been discovered by any geometry or any rational philosophy: for instance, that intelligent principle which exists in animals, or the soul, which, together with the body, constitutes their life.

We may perhaps learn the mechanism of the organs, and may know how they are moved by muscles, tendons, fibres, and nerves, by the feet, arms, and other members ; how the undulating air is received by the membranes and instruments •of the ear, and is represented within the chambers of the brain by means of sounds ; we may also come to know how the ether exhibits a mode of motion of itself in the eye, and runs through the tissues of its nerves till it reaches the meninges of the brain ; how a motion extends and expands itself out of a grosser into a more subtle medium, and thus arrives more distinctly at the most subtle membranes. Perhaps, too, we may know how a motion is received by some subtle active principle, and how it does not and cannot relax its tension till choice has determined it into act by means of the will. We also see every emotion and mode of the soul exhibited mechanically in the body. But after all, what that intelligence itself is which is in the soul, which knows and is able to determine, which knows and is able to choose, and to let one thing pass-out into act and not another, we are obviously ignorant. For it does not consist merely in the relation or reaction of motions proceeding from grosser media, through such as are more subtle, to that contexture of active principles where perception takes place ; for this exists in the elements every-

where, yet there is not, on this account, an intelligent principle in everything belonging to the elementary world. In the souls of brutes, too, there are the indications of a kind of intelligence. Birds know how to form their nests according to just proportion and mechanical rule; they know how to deposit their eggs, to sit upon them, to hatch and rear their infant brood—functions that are variously performed by various species according to the difference of nature in their tender offspring. Other animals are aware of the approach of winter and make timely provision against it. Ants throw up their hills,, and diligently carry and store up in . them such things as ought to be under shelter during the winter. Bees know to suck honey and wax from flowers; to construct hexagonal cells, and to store and fill them up with honey. The elder ones know how to send out their offspring to form new colonies ; to kill their useless companions and drones, and to cut off their wings; in a word, they know how to make provision that they may not perish with hunger in the winter when no sustenance is to be found ; not to mention other marks of their prudence and natural intelligence. We see the spider construct her artful snare with crossing lines and binding circles, and then lying in the middle, so place her feet as instantly to feel on which thread of her web the booty has fallen. What marks of prudence excite our wonder in the fox ! What artful frauds and cunning tricks does he practise ' What wonders of a like nature are observable in innumerable Other animals ; and all flowing naturally from a grosser kind of soul. But what is the nature of this intelligence, pertaining to the active being of animals as an inherent quality,, geometry has hitherto been unable to discover; and we are yet ignorant whether the laws to which it is subject are similar to those of mechanics ; although it cannot be denied to have laws, because it has an orderly connection, and is natural.

In the soul of brutes there is some idea of this intelligence ; in man it is more distinct and rational; in the'

Infinite it is infinite, and infinitely surpasses the comprehension and sphere of the highest rational intelligence. There are also many other things which occur in the world that cannot be called geometrical. Thus there is a Providence respecting all things, which is infinite in the Infinite, or in the Being who is provident in the highest degree ; and there follows thence a connection or series of consequents, according to which all circumstances are determined and arranged, by causes and the causes of causes, toward a certain end. We see from experience, and *a posteriori*, that there is such a connection of incidentals, from causes, and their results in producing a given end ; but to know the nature of this connection, *a priori*, is not within man's province or that of geometry. There are also innumerable other things which we in vain endeavour to explore by geometry and *a priori*; as, perhaps, the nature of love. We see, *a posteriori* that it has its consistence in the connection of things; that the exercise of love independently of the organic body is antecedent to corporeal pleasure ; and, being conjoined in the animal with intelligence, produces everything which can conduce to the preservation and perpetuation of its kind. The ancients regarded love as being of great importance, attributing to it the production of the universe ; and many will assert that traces of intelligent love are to be found in plants and inanimate objects. There is probably an infinite number of other things, of which we have no knowledge and which yield no obedience to the known laws of mechanics. Hence we may conclude, that there are qualities in the soul that are still very remote from mechanical apprehension : so that, even if we knew all the mechanism and geometry of the visible world, of animal organization, of plant life, or any other department of nature, there is still an infinite number of things of which we are ignorant.

But since intelligence in the soul is not mechanical, but only the mode in which the soul operates, we next enquire what that is in the soul which is not mechanical, and

what is its essential rational and intelligent principle which is not subject to known laws. The rational principle in the soul does not consist in knowing many things which the world naturally exhibits and presents to the senses; for this knowledge has reference to the world, the senses, and experience. The rational principle does not consist in knowing the figures and spaces in which motions terminate ; for this is the province of geometrical science. The rational principle does not consist in knowing the proportion between figures and spaces, and the other rules and proportions of motion, by which the world acts and produces its phenomena ; for this belongs to nature, mechanics, science, and philosophy. But the rational principle consists in knowing how, and at the same time in being able, to arrange into such order and connection the reasons known from the world, so as to view their analogy ; yet this presupposes an active principle, or a certain force, impelling into motion all those things which inhere in a similarly orderly manner in its organs ; that is, it presupposes a soul. The rational active principle derived from this, consists in knowing how, and in being able, actually to elicit from analogy a third or fourth truth previously unknown. A subsequent rational principle consists in being able to form a certain series and connection of such reasons, consisting of things known and unknown in succession, till it distinctly arrives at the end it has in view. To accomplish this, all the sciences must co-operate with reason; as geometry, mechanics, rational philosophy, together with abundant experience. The rational principle in the soul, therefore, is the continual analysis of those things which inhere in the same orderly manner in its organs.

These observations may suffice respecting the second means of arriving at a mechanical knowledge of the secret things of nature; we now come to treat of the third means, or the faculty of reasoning.

3. The third means by which we may arrive at a true philosophy in cosmology, and at the knowledge of hidden

nature, is the faculty of reasoning. Let experience and geometry be given ; that is, let a man possess the utmost store of experimental knowledge and be at the same time a skilful geometer, and yet suppose him to be deficient in the faculty of reasoning correctly, or of comparing the several parts of his knowledge and experience, and presenting them distinctly to the soul ; he can never know the mysteries and inward recesses of philosophy. Knowledge without reason, —a vast mass of things in the memory without judgment to separate and clearly distinguish them, and without the talent of deducing the unknown object of inquiry from certain known data, by means of a rational or geometrical analysis—in a word, the possession of the means without the faculty of arriving at the end, does not make a philosopher: the maids of Parnassus will not entwine any laurel-wreath, plucked from the sacred hill, around the brow of him who is destitute of this talent. The faculty of reasoning correctly, and of arriving at the end in view by the proper means, which are experience and geometry, is the characteristic of the rational man. But a like faculty of reasoning is not given, and at this day cannot be given, to all. There are some who are unable to attain to it through some defect of nature ; being deprived of it from the first moment of their birth by disease or congenital fault. We see children born into the form and likeness of their parents ; with the same face, that is, with the signs and marks as if of the same face; the same disposition ; the same situation and arrangement of their organs; with much the same faculty of reasoning as their parents ; and inheriting their very diseases, which in this case are called hereditary. Some also, by defect, are born blind, or deaf, or idiots, having the brain of improper weight, dimension, or form, who, therefore, are able to acquire nothing, or very little, of the faculty of reasoning, by any use or practice; for their organs cannot be so disposed as to afford a distinct communication of motion from the senses to the soul and its reason. A passage may, indeed, be open to the



more subtle interiors, but it is one that is irregular, indistinct, imperfect and dark. There are others who labour under no natural defect; but who, having been deprived of the advantages of a proper education, and, being without experience, have been unable to acquire any talent for reasoning; the way that leads from their senses to the soul may be compared to the passage of rays through a very dense medium and through a cloud to the eye; their animal motions do not arrive distinctly at their active principles, but stop, as it were, in the middle of their course ; the forms of the motions, as in other living things, seem scarcely able to travel any further, because the organs are not yet fashioned, as it were, by use and cultivation, that is to say, have not yet become contiguous to, and conjoined with, their more subtle life. The organs are indeed potentially there, but require exercise to form and fit them for use. But when, by experience and knowledge, they are adapted to motions and tremors of every kind, there are then innumerable things inherent in them, which, by some active principle or motive force, are capable of being brought forth into act, and so arranged as to give their possessor the capacity to reason, or to display the operations of his rational faculty. Unless a motion can penetrate successively, by means of contiguity, from grosser things toward those which are more subtle, it either stops in grosser or mediate things, or passes into a state of obscurity. In proportion, therefore, as a man's store of experience is greater, and its disposition and distribution through the organs are more perfect; in proportion, also, as the harmony of his mediate organs is more exact, and their form better adapted to the conveyance of every kind of tremor or vibration, and in proportion as the passage is more deeply opened, in series and continuity, to the most subtle things of all, so much the wiser may the man become.

It was said above, that the faculty of reasoning is acquired by cultivation, or, that we are rendered rational by exercise

and education ; and likewise, that we may become more rational in proportion to the length of time through which we advance to maturity, or in proportion to the number of years which are required to form and consolidate the organs. But we treat of this below.

But that the nature and quality of the faculty itself may be clearly understood, it must be observed, that our knowledge and experience must be so arranged and harmoniously diffused throughout the organs, that immediately on the approach of any active principle or power, all those things so arranged that are of a similar nature, should immediately vibrate and run as it were to meet it, and present themselves to the soul simultaneously ; but no others, except obscurely, by virtue of their connection. It is as if there were a hundred musical strings of equal length and tension, one of which being moved or struck, all the others vibrate without being touched, run as it were together into the same sound, and present themselves at once in concord to the ear. This being premised, it follows that our wisdom is proportioned to the acquisitions of our memory.

Suppose, then, that the means are ours, that we have acquired the power and faculty of reasoning and have brought it into actual operation, we may arrive at true philosophy, or may be able by the aid of experiments to speak and treat of the phenomena of nature from their causes; in fact, we may arrive at the very fountain-head from which all things that appear mysterious are derived. With respect to the knowledge of the elements, which is the chief subject of discussion in the present volume of our *Principia*, I confess that it appears to be of the most secret nature, being remote and incapable of being perceived by the senses. Nevertheless, the motions of the volumes in the elements are perceptible to our sight and hearing. Thus elementary nature places before our eyes the most diverse phenomena, by which, as by so many tokens, she seems to reveal herself; now sporting half naked before our view, now concealing herself; yet by her

phenomena ever displaying her image to observation as in a mirror. For we see that all things are acted upon and put in motion according to laws ; that they all flow from the motion and arrangement of small bodies of different forms in mutual contact. If, therefore, experiment and geometry are called to our aid, I have no doubt, under their auspices and leadership, that we can arrive at some knowledge of the things in our world that do not appear to our sight; especially since elementary nature, as just observed, is perpetually sporting so beautifully before our senses, and entertaining them with her illusions, always showing her face half unveiled to geometers and philosophers. Let us then call the proper means to our assistance, and we shall probably arrive at the true causes and knowledge of things occult. Unless, however, principles be formed with which experiment and the phenomena of our world agree, geometry also adding its calculus, they are to be regarded as the mere fictions and dreams of a delirious mind. But if our principles agree with experiment, and are also confirmed by the test of geometry, then it may be permitted us to liken them to truths, and to declare them to be a legitimate offspring. How far this may be affirmed of my *Principia*, it is for the reader to decide.

4. By a true philosopher, we understand a man, who, by the means above treated of, is enabled to arrive at the real causes and knowledge of those things in the mechanical world which are invisible and remote from the senses ; and who is afterwards capable of reasoning *a priori*, or from first principles or causes, concerning the world and its phenomena, both in physics, chemistry, metallurgy, and all other sciences or subjects which are under the government of mechanical principles; and who can thus, as from a central point, take a survey of the whole mundane system and of its mechanical and philosophical laws. For the mechanical world of nature is not unlike a spider's web, and natural philosophy may be compared to the spider herself. The spider chooses a situation which will permit her to fasten her threads to the

various parts of surrounding objects; the radii which she draws she then causes to meet in a certain centre, and these she ties and connects together, at various distances, by circles and polygons ; her design being to bring all the parts of the sphere which she occupies into contact with one another. Then betaking herself to the middle or centre, she so plants her feet on the threads or radii, as to be able to perceive the smallest particle that may alight on any of the radii at any distance ; so the creature snares her food, and while thus lying in ambush, she knows immediately whether anything has come into her web, and feels into what part of it the prey has fallen ; for by that very thread and no other, she darts out instantly and seizes her entangled victim.

Now nature herself closely resembles this spider's web; for she consists, as it were, of infinite radii proceeding from a certain centre, and connected together, in like manner, by infinite circles and polygons; so that nothing can happen in one of them which does not immediately extend itself to the centre, and from this it is reflected and distributed through a great portion of the fabric. It is by such contact and connection that nature is able to perform her operations, and in this her very essence consists ; for wherever this contact is interrupted, wherever a thread of the web is broken so as to dissolve the connection between the centre and its circumference, there nature herself ceases and terminates. Natural philosophy is capable of taking her station, with nature herself, near this centre to which all natural things have reference, or where all the motions or affections of all the surrounding parts are concentrated. She is capable of instantly knowing and feeling anything that occurs in the peripheries, what it is and whence it comes; and is able to explain to nature her companion the reasons why the phenomena occur successively, and by a kind of necessity, at a definite distance, in a definite manner, and in no other. In a word, she is able, from the centre, to take a simultaneous view' of her infinite circumferences, and survey all her

-mundane system at a glance. She does not therefore take up her abode in the mere outward circumference, or like a fly entangle herself with great labour and effort more and more in the web and become the prey and sport of her own wisdom.

Were it possible, by such means, to bring to light the nature of the elementary, and afterwards that of the metallic, vegetable, and finally that of the animal kingdom, how great would be the advantages which the world would reap from the discovery ! For if we knew *a priori* the causes of the things in these kingdoms, and were able to speak of them, commencing from the same principles and causes from which nature herself brings forth and manifests her phenomena, every one might then know the objects which she has in view ; every one might then give responses as from the inmost recesses and from behind the veil of nature's temple ; every philosopher would be a Themis or Apollo, that is, would know all the phenomena that could exist, and would hold the vastest sciences in a nut-shell. But if any one is content with devising principles, and is so indulgent to his imagination as not to look for the evidence of them in geometry and their agreement with physical facts; or if he forms to himself a distinct theory for every series of phenomena, and for every series of experiments contrives new links of connection, and, when his fragile ties give way, endeavours to restore their coherence with clumsy knots—such a one can never be admitted to these oracles. Surely nature will look at him and laugh at him as a bungler who wastes his time in dreamy toil; or as an infant wishing to build nests in the air, to provide them with eggs and there to hatch young; or as a simpleton employed in making for himself wings of wax, vainly regarding himself, not as Icarus, but as Mercury—ambitious of directing his flight towards the sun—and believing, as the poet sings,

“ I may not thwart

The prompting god, that bids these lips disclose  
Oracular the secret of the skies,

The scheme and purpose of the Mind Supreme,  
 And all the mighty mysteries, hidden long  
 From earlier quest."<sup>1</sup>

No man seems to have been able to arrive at true philosophy, since the age of that first of mortals who is said to have been in a state of the most perfect integrity, that is to say, who was formed and made according to all the art, similitude, and scheme of the world, before the existence of vice. All who are governed by a right mind, aspire after, indeed, are intensely desirous of arriving at the same degree of wisdom, as at something which has been lost. But how far it is possible to succeed none but the true philosopher can see ; he who is only in part a philosopher, or who wishes to be reputed one, may imagine himself to have arrived at the goal, and even to have proceeded beyond it; although his wisdom is mere folly.

The reason why man in a state of integrity was made a complete philosopher, was that he might the better know how to venerate the Deity—the Origin of all things—that Being who is all in all. For without the utmost devotion to the Supreme Being, no one can be a complete and truly learned philosopher. True philosophy and contempt of the Deity are two opposites. Veneration for the Infinite can never be separated from philosophy ; for he who thinks himself wise, whilst his wisdom does not teach him to acknowledge the Divine and Infinite, that is, he who thinks he can be wise without a knowledge of and veneration for the Deity, has no wisdom at all. The philosopher sees, indeed, that God governs His creation by rules and mechanical laws, and that the soul governs the body by rules and mechanical laws ; he may even know what these are ; but the nature of that Infinite Being, from whom, as from their fountain, all things in the world derive their existence and subsistence—and what is the nature of that Supreme Intelligence with its infinite mysteries—he in vain strives to know.

<sup>1</sup> Ovid's *Metamorphoses*, Lib. xv. 11. 144-147, translated by H. King.—7'rs.

When, therefore, the philosopher has arrived at the end of his studies, even supposing him to have acquired so complete a knowledge of all mundane things that nothing further remains for him to learn, he must there stop; for he can never know the nature of the Infinite, of Supreme Intelligence, Supreme Providence, Supreme Love, Supreme Justice, and other infinite attributes. He will, therefore, acknowledge that in respect to this supremely intelligent and wise Being, he knows nothing; he will therefore most profoundly venerate Him with the utmost devotion of soul ; and that veneration, from the mere thought of Him, will cause his whole frame, or membranous and sense system, from the inmost to the outermost principles of its being, reverently, yet agreeably to tremble.

As nature is the beginning of the changes that occur in the world or natural universe, or as nature is the motive or active force, or collection of forces, it follows that the world is dependent on nature and inseparable from it; and that the world is nothing without nature, and nature is nothing without the world. But Infinite existence is still Infinite existence independently of the world ; no conception can be formed of a world without Infinite existence ; it is everything and it is universal in the world. We see then that without the world nature cannot be, but that the Infinite can, and that the Infinite Being is capable of being separated from the world. We see also that all things were produced by the Infinite, that the world was created by Him, and with the world nature herself. Nature is only a word which connotes all the actuating forces proceeding from the first motion of the Infinite till the world was completed ; with this first motion it begins ; and as this is produced by the Infinite, so also is nature. They, therefore, are mere children, and have reached scarcely the first threshold of true philosophy, who ascribe to nature the origin of all things, to the exclusion of the Infinite ; or who confound the Infinite and nature together; when yet the latter is only an effect, or thing caused, the Infinite being its Generator and Cause. Nature,

however, when once produced, may be called the generator and cause of the world, in so far as all things afterwards successively exist by derived motive forces and modifications. Yet it cannot be called the first cause ; for no other idea can be conceived of the first motion or mode, than that of an immediate production from the Infinite ; therefore this mode cannot be called an attribute or the essence of the Infinite, the essence of the Infinite consisting in Itself alone. Nor can it be denied that the Infinite existed before the world, (which will be the subject of our second chapter); neither can this mode be a mode of the Infinite; for no such thing can be said or predicated of the Infinite except by way of eminence; but it is an immediate production from the Infinite. It follows, therefore, that nature, beginning from such motion or mode, is a thing caused and produced.

Now as all nature together with the whole world, is the work of God Himself; as all contingent circumstances, before the world was produced and completed, are to be ascribed solely to His wisdom ; so also, in case He should be pleased by other contingent causes to display new phenomena, whether foreign and contrary to the nature of our world, or in conformity with it, yet such as cannot be produced by any other active principle than the Deity—to the same Infinite Wisdom must these also be ascribed. Thus true philosophy leads to the most profound admiration and adoration of the Deity ; nor can anything be found to diminish, but an infinity of things to increase, this admiration. As when a man sees that all things are from the Infinite, and that in comparison with the Infinite he himself, as a finite being, is nothing; when also he sees that all his own wisdom and philosophy, in comparison with the Divine wisdom, bear the same proportion as the finite to the Infinite—that is, as nothing.

Neither does true philosophy detract from the credibility of miracles, all things being ascribed to the divine omnipotence, as the origin of the world, and its formation by various means and successive changes. There is no contingent mean,



tending to the perfection of the world, which is not a miracle. The world itself is a miracle; whatever exists in any of its kingdoms, whether in the animal, the mineral, or the vegetable, exists by a miracle, because it exists by a contingent mean, which, by a series of others, is terminated in the Infinite itself, as in the first cause of all contingent means. For it cannot be denied that intermediate causes and changes proceed successively from the Supreme Being, who produces all things perfectly, and conducts them to their destined end. Now what He thus produces by contingent means and causes, cannot be said to be contrary to the order of universal nature, but according to it ; and although something may appear which does not agree with the nature of our world, or there may be phenomena not consistent with the mechanism of our world, yet even in this case they must exist from certain causes, which, like the world itself, derive their origin from the Infinite alone. And relatively to the mechanism of our world, it is a series of miracles alone that could produce one such phenomenon or miracle ; similarly when returning to its first origin and cause by contrary contingent means, it would be by a series of miracles alone; that is, supposing our world to remain the same as before the miracle took place. All things which exist in any other world, were they to occur in our own, would be miracles, as being contrary to its laws of motion—to its order of succession and modification; although produced according to the order of nature, and in their own world quite natural. In short, if a miracle exists, it exists from the Infinite ; if from the Infinite, it exists by means of causes. There may also be miracles which agree with the mechanism of our world, and others which are foreign to it; but neither can be produced but by some one or other active infinite principle, of which we can form no idea, and, consequently, cannot understand its cause.

But probably you may wonder why I affirmed, at the beginning of this chapter, that all our wisdom or true philo-

sophy must be acquired by the use of means ; and that the way to reason and things prior is to be opened by experience and posterior things; thus, that our body and external senses are our only teachers and leaders, leaving but little to the mind, from which, nevertheless, as its fountain, all reasoning must proceed, or to which all things must have reference ; consequently, that the mind of itself, without the use of means, is unable to give any instruction or direction to its body. I will, therefore, draw a picture of the two states of man; first of his state of integrity, which was most perfect, and then of that perverted and imperfect state in which we mortals live at this day. From such a comparison it will probably appear, that it is only by the use of the means above mentioned that the way to the most subtle active principles can be opened, and that this way can only be prepared by experiments.

To begin, then, with man in his state of integrity and complete perfection. In such a man we may conceive that there was such a complete contiguity throughout the parts of his system, that every motion proceeding with a free course from his grosser parts or principles could arrive, through an uninterrupted connection, at his most subtle substance or active principle, there being nothing in the way which could cause the least obstruction. Such a man may be compared to the world itself, in which all things are contiguous from the sun to the lowest part of our atmosphere. Thus the motions about the sun, or rays, proceed with an uninterrupted course, and almost instantaneously, by means of contiguity, through the more subtle or the grosser elements, through ether to the air, till they reach the eye and act upon it, by virtue of such connection, as if they were present; for contiguity occasions the appearance of presence. When, therefore, the most subtle active principle of man, by the providence of God, clothed itself with a body, and added, by degrees, parts upon parts, all the motions in the most subtle elements which were present would necessarily move or affect that extremely impressionable and tender substance, and would gradually

imprint themselves and their own mechanism upon it. So also would the motions in the grosser elements, such as the air; for this, always moving and undulating around it, and perpetually acting upon the same substance, would also form to itself something similar, and, by its continual motion, cause itself, as in the case of the other elements, to be received within. The same would occur in regard to whatever was fluent in the air with a more unequal motion, for the atmosphere is always stored with the effluvia of plants, etc.; this, therefore, by its continual contact, would form its own mechanism in the sense of smell. In a word, during the growth of the very tender parts possessing motion and life, every motion that was perpetually present must necessarily have left indications of itself, and must consequently have naturally formed its own mechanism, so as afterwards to be received still more interiorly, but in the same manner as in the yet tender substances.

The man thus formed, in whom all the parts were coordinated to receive the motions of all the elements, and to convey them successively, when received, through a contiguous medium, to the extremely subtle active principle, must be deemed the most perfect and the first of all men, being one in whom the connection of ends and means was continuous. In a short time so perfect a material and active being would by the senses alone become possessed of all the philosophy and experimental science natural to him ; for whatever could present itself to his senses, would immediately flow, by connection and contiguity, to his extremely subtle and active first principle. Thus whatever presented itself to the eye would immediately flow, through the minute membranes set in motion by its undulations, to those successively more subtle, till it arrived at the most subtle principle. The case would be

- the same with motions occurring in the sense of sight, smell, and taste ; these operations would also be most easily transmitted to the extremely subtle principle, through the medium of the sight, and the harmony of the several senses. As,

therefore, the whole man was constructed according to the motions of the elements, and those motions were capable of arriving, without interruption, through a medium so continuous and elastic, at the extremely subtle active principle,—what conclusion can we draw but that such a man must have possessed the most complete, perfect, and distinct faculty of reasoning ; that all the mundane system or motions of the elements must have become familiar to him after a little 'Contemplation and experience ; that every relation of their motions, being impressed upon all his organs as it were naturally and from his tender infancy, would be felt with perfect regularity from his external parts or senses to his soul; and that the soul, being furnished with such a body, would naturally be so well acquainted with geometry, mechanics, and the mundane system, as to be able to instruct herself without a master, from the simple contemplation of the phenomena of nature and the objects of sense. Such a man would be capable of taking his station as it were in the centre ; and surveying from thence the whole circumference of his system at a single glance, he would be able to understand things actually before him, as well as all other things in detail, both in regard to those that had occurred, and those likely to happen.

Let us now consider the perverted and imperfect state of man into which we are born at this day. In this state we see that nothing can be fully known without the use of means; that nothing can penetrate to the ultimate active principle, or to the soul, except by means of continual experiments, by the assistance of geometry, and by the faculty of reasoning acquired from both ; we see that the way which leads to this most subtle and intelligent power is almost entirely closed, and capable of being opened only by continual cultivation and exercise, that is, by perpetual experiment and the practice of philosophizing, and by the faculty of reasoning thence acquired. We see that even then the way is not, as it was in a state of integrity, so open, as to preclude the

necessity of continual experiments, by means of which, as things constantly present in the memory, all motions or affections may be remitted to the most subtle principles of our organism, and the passages thus kept as it were constantly permeable and open. For the nature of man's state at this day, and its unlikeness to his former state, are well known; how possessed he is by affections quite foreign to rationality : how continually his organs are acted upon by them ; how his interior structure has suffered violence from vices, so that the connection between his more subtle and grosser structures is drawn asunder, distorted, and rendered less contiguous than before. What power the affections of the body, as pleasures and cupidities, have over the fine-membranes, is well known from experience ; for they are able to induce their own affections on the fibres, muscles, and nerves, both the more subtle and the grosser. They are able to distort them ; their impression appears in the grosser and external appearance of the face, for we often see the countenance disfigured by them and totally changed in a moment. What then must be the effect on the membranes and more-subtle parts, or on those mediate membranes and fibres-through which an affection is gradually transmitted to the most subtle active principle ? In these parts are the organs leading to the most subtle principle. If then these are continually disturbed, they are totally disfigured and distorted ; consequently, the natural connection, which before was perfectly regular, is severed or broken.

Now bodily pleasures, lusts, desires, and vices of this kind have almost filled the whole man. Increasing with time, they pass from practice into habit, and from habit become so completely spontaneous as to govern the will itself; in other words, lusts at length take possession of the will and withdraw it from the control of the reasoning soul, so that at length man is capable of scarcely any voluntary action but what proceeds from these emotions and desires, and is frequently without the consciousness of rationality. When-

the will is thus agitated by almost nothing but innumerable temptations and enticements, the consequence is that it arranges all the organs that are intermediary between the body and the mind, with their series and structure, into the likeness of its own emotions, or into its own form ; and when their structure is thus rendered wholly subservient to the seductions of the senses, it can no longer be inclined and moved by the mind, except with difficulty and imperfectly. Such an organization, acquired by indulgence in pleasures and depraved emotions or appetites, is also left by the parent as an inheritance to his children; for we often see children resembling their parents in their face and external form, and it is equally common to observe in them a similarity of mind, that is, a disposition more prone to certain lusts than to others. Children, therefore, are born and formed also after the interior countenance and likeness of their parents ; and thus the whole assemblage of the organs that mediate between the body and the mind, is, from its rudiments, or from the womb and the cradle, formed after that of the parents, tarnished with the same stains, full of the same corruption, and rendered naturally, and, as it were, radically disobedient and unresponsive to the most subtle modes or modifications, and tremors or vibrations of the mind, and hence is slow to receive them.

As then these disorderly emotions of the body have occupied almost the whole man, and have also taken possession of the membranes in which the mediate motions take place, it is no wonder that at this day the faculty of reason is only to be acquired by the use of means, and that it is not possible to arrive by reasoning at the most subtle substance or principle, without the aid of analytical rules similar to those of geometry to be taught us by a master. These bodily emotions and vices, which seem to have done such injury to the mediating organs, are not unlike those very dense and dark clouds, which, intervening between the sun and the eye, deprive it of the use of light, although some rays still penetrate

through the clouds, not in regular order, but with confused refraction; hence, when the sky is thus overcast, we are deprived of the contiguity of nature, and are unable to discern the firmament and the sun itself. Such a cloud, as it always overshadows our heaven, can be dissipated only by suitable means ; but as some traces of it, either inherited or acquired, will always remain, so must our use of the means for its dispersion be constant. That vices and lusts not only disturb, but also destroy, the natural connection of the organs and modifications that lead to the reasoning faculty of the soul, may be illustrated by example. Anger and an intemperate excitement of the body so dissolve this connection as to render a man irrational, utterly incapable of reasoning, insane, and more like an animal than a rational being. Look at the effects of intoxication. How it takes away from the soul all use of reason—all power of analysis ! Thus the connection is broken, so that nothing but a confused object is presented by the organs to the soul; no difference is discerned between things like and unlike ; but all, both like and unlike, rush on with the activity imparted to them, and present them confused to the soul. The case is similar with all the passions, when they exceed the bounds of moderation.

I have said that, in his state of integrity, man was master of all philosophy or worldly knowledge, and this too of himself, by virtue of the perfect mechanism of his organisation, that is, by nature ; and that, being furnished with such excellent senses, nothing could be concealed from him, because he was formed responsive to all the motions and operations of the world and nature. I have said further, that nothing could exist in the world from the regular connection of causes, which would not instantly flow, as through a most clear and pellucid medium, with a certain sensation, to the mind ; that is, that all the sensations of each of his organs would penetrate to their most subtle principle, without delay, confusion, or obscurity. But when every modification in the world, of whatsoever kind, had thus arrived at its ultimate, or

at his soul, it necessarily follows that his knowledge and attainments would stop there, and that he would regard and venerate, with a most profound admiration, those other countless things that exceeded the bounds of his intelligence; that is to say, that most vast Infinite—infinately intelligent, infinitely provident—which begins where man and his finite faculties, intelligence, and providence, terminate : he would see that in this Infinite all things have their being, and that from it all things have their existence. As, therefore, all his sensations thus necessarily penetrated to their ultimate seat without any intervening obstacle, and there settled into a most profound veneration, it follows that this perfect man's veneration of the Deity was equal to his wisdom, and as constant as the action of his senses; we may, therefore, conclude, that the more profound the wisdom, the more profound will veneration be. Further, no one could better know and acknowledge the infinite grace of the Deity, than that first and wisest of men ; whence it follows, in the same manner, that he loved the Deity supremely ; for when we greatly respect any one, acknowledging at the same time the benefits and favours received from him, especially when we are intimately associated with him, we are secretly impelled also to love him. We may, therefore, conclude again, that the wiser a man is, the greater are his veneration for, and love of the Deity. His delights wholly terminate in the love of God—a love which exhausts and replenishes all sense of delight. All the delights of the world, resulting from its variety, are nothing unless the mind also partakes of them; for no human delights can be real, without the participation of the soul, since the more refined delights are lacking : and the delights which the body and soul are capable of enjoying together are not genuine and true unless they have some further connection, and terminate in the veneration and love of God, that is, unless they have reference to this love and ultimate end, in a connection with which the sense of delight most essentially consists.



It may, therefore, be very reasonably inferred, that the delights of the first man consisted in this ; that the end of the delights which he derived from the contemplation of a world so perfect and pleasing left to him and posterity in succession, and from the agreeable perception, by means of his senses and organs, of the motions existing in all the elements, was the love of the Deity. Supreme veneration and supreme love of the Deity could not exist without the supreme worship of Him. What we venerate and love, that we worship; for the utmost degree of veneration conjoined with love must be active and operative, and must extend to the will and actions. As no other desires occupied the whole man when in such a state, no others could rule his will; for the will is ruled by the inclinations and desires of the soul and body; neither could he bring anything into the will, nor could the will bring anything into act, but what was applicable to the supreme adoration of the Deity, and to the giving to Him thanks full of veneration and love; for these are the delights to which the man who was master of himself and of all his delights and desires would wholly devote and apply himself. For what could be more delightful and voluntary, in such a state of mind, than to ascribe perpetual honours to a Being, supreme, incomprehensible, and so closely bound to Him by love—to pay to Him unceasing vows, to worship Him with constant praise, secure always of His favour and acceptance ? Therefore the wiser a man is, the more will he be a worshipper of the Deity. From the same reasoning it follows that God must have loved such a man supremely; for love is not only reciprocal, and according to connection, but is also greater in its prior degree, and becomes less in a derived degree.

But the contrary to all this must necessarily take place in a man not in a state of integrity, and in whom the connection has perished. Such a man has not the wisdom, the veneration, and adoration of the Deity we have described ; and as his knowledge of the Divine benefits and grace is

also imperfect in proportion to his lack of wisdom, so neither can he have such love. In a word, he cannot have any such veneration, adoration, and love of the Deity, as that of the wise first man, unless he receives them from another source, that is, immediately from grace. But whatever veneration, worship, and love may exist in a man so changed, and in whom the connection is broken by vices and lusts, they can never be unaccompanied by fear, because he never can be without cause of fear. Neither can love be supposed to exist in God towards man, after the connection is broken, but, instead of love, justice. Man's having cause for fear implies justice in God. It is, therefore, agreeable to reason to conclude that there would have been no love in God towards man in his unconnected and discontinuous state, but only justice, had not the Infinite and Only Begotten for this cause become Man, in order that in Himself as a Man, and consequently through a certain connection with Himself, He might restore a connection with the Infinite in those who are like Him.

## CHAPTER II.

### A PHILOSOPHICAL ARGUMENT CONCERNING THE FIRST SIMPLE OF THE WORLD AND ITS NATURAL THINGS > THAT IS, CONCERNING THE FIRST NATURAL POINT, AND ITS EXISTENCE FROM THE INFINITE.

1. No rational and intelligent philosopher can deny that the first entity was produced from the Infinite, as well as the rest in succession, or all the parts of which the world is composed. For the world cannot exist from itself, because it is finite, and consists of parts; neither can these parts exist from themselves, because these also are finite, and consist of their parts ; nor again can these latter, for the same reason. In short, nothing that is finite can exist from itself, that is, without purpose and a cause. For there must also be a reason why it was finited in this way, and in no other; or why it has reached this limit, and no other. In other words, nothing can exist without a cause, save the Infinite. The Infinite alone exists without a cause, or from itself; nor does it consist of parts. Thus the ultimate cause of things terminates or begins in the Infinite, that is, in Him who exists of Himself, and who consists not of parts; so that from Him finite things must of necessity have proceeded. What is finite, therefore, takes its origin from what is infinite, as an effect from its cause, and as a thing limited from what is in itself unlimited, yet having the power to limit all other things. Whatsoever was produced of a finite nature, could not be finited by itself; nothing finite can exist by itself, because it must be finited before it exists; and if so, it must be finited by something else;

therefore it follows, that a finite must necessarily exist by that which has the power of finiting it, and which of itself is infinite. In a word, it is most evident from rational philosophy, from the light of nature and the intelligent soul, as well as from the Sacred Scriptures, that the first entity, as also other entities in successive derivation from it, of which the world is built up, and by which it is connected together, were produced by and from the Infinite.

Rational philosophy itself recognises a certain connection and succession, both in the original existence of things and in their subsistence; nor can it terminate its idea concerning the existence, succession, and series of things, except in what is simple and unlimited, or in that which may be said to have only one limit. With respect to the existence of things, sound philosophy teaches us that things which are much compounded take their origin from things less compounded ; the less compounded from those which are still less so; these from their individual substances or parts, which are least of all compounded, or least of all limited ; and these again from things simple, in which no limits can be supposed, except one ; from which circumstance also they are called simples. But whence is this simple, in which only one limit is to be conceived ? And whence its limit ? It cannot exist by itself; for there must be something by which it may exist, if it has a limit, if it is simple, or if it is capable of giving origin to two or more limits. Extending the inquiry, therefore, by the same philosophy we rationally proceed to the conclusion, that such a simple derives its existence from the Infinite ; but that the Infinite exists of itself. Again, if we contemplate the successive progression of causes, it is rational to conclude that nothing finite can exist without a cause; that things which are much compounded, or which consist of many individual parts, neither could be compounded, nor could subsist, without a cause by which

they were compounded, and on account of which they remain so; for a cause always precedes, and afterwards accompanies that which exists from it. The individual parts of such a composite must in like manner be compounded of, and subsist from, individual parts still smaller; and these again, by the order of their succession, from things simple; but still things simple can neither exist nor subsist from themselves. Wherefore there must be an infinite something; there must be something infinitely intelligent, which not only purposes but also executes its designs ; which must be both the power which can create and the active agent which does create all things that exist. Therefore, composite things derive their origin from simple ones; things simple from the Infinite; and the Infinite from itself, which is the sole cause of itself and of all things.

I have said that all finite things came into existence successively; for nothing can be at once such as it is capable of becoming, except the Infinite. Everything finite acknowledges a certain mode, by which it is what it is and nothing else ; a mode, by which it is of such a form and no other; a mode, by which it occupies such a space and no other. In a word, all finite things are modified; and therefore they acknowledge a mode prior to their modification, and according to which it takes place ; they acknowledge also a time in which they were so modified. Hence nothing is at once what it can become except the Infinite. All finite things must necessarily undergo different states successively; but not so the Infinite. And thus we perceive, that all things except the Infinite have their modification, but that in the Infinite there is no such thing as development, simply because He is first and the original cause of all modifications. Hence also it follows, if nature consists in the modification of things, that the Infinite is the origin and the author of nature.

Thus does rational philosophy first acknowledge something produced from the Infinite, and some simple as the origin of

entities not simple. This first entity, or this simple, we here call the natural point.

2. Geometry itself also acknowledges a certain simple and primary beginning of its existence ; and this it calls its own or mathematical point. Geometry recognises that a point is something simple, since it does not know how to limit it either in figure or in space. Hence it declares that it is without extension and indivisible; and yet that it is of such a nature, that by its motion, lines, areas, and solids can be generated ; that by its motion, and multiplication into itself, finally spaces may be filled ; and that by its motion the successive derivations and parts exist by means of which things are limited and bounded. In a word, geometers ascribe the origin of all' their figures and bodies to such a point, yet not as belonging to the science itself, because that is incapable of defining it in a geometrical manner. Thus geometry seeks for its origin, beyond itself: deriving this point not from itself, but from rational philosophy. Now since the world consists of finites only, and since it is geometrical and mechanical, therefore, like all finite and geometrical things, it acknowledges its origin to be in a point, which is the same as the natural point of which we are now treating.

3. The Holy Scriptures themselves also give us plain information on this subject, and teach us that the world was created by God, or by the Infinite ; that it was created successively ; that it was created in time ; and that the Infinite is an Ens in itself; that it is Being which is ; that it is all in all, that it is universal; and further, that it is allowable to contemplate it *a posteriori*, or from effects, but not *a priori*, or from reason. And whatever is confirmed by Holy Scripture is in no need of confirmation from reason, from rational philosophy, or from geometry, this being already sufficiently implied in the fact of confirmation by the Infinite Himself.

4. Rational philosophy will not admit that anything can be or exist without a mode; and since a mode in limited, finited,

or in physical things, consists solely in the variation of limits, it, therefore, follows that nothing can exist without motion. Whatever is devoid of motion, remains such as it is ; whatever is at rest, produces nothing. If anything is to be produced, it must be produced by a mode or by motion ; if anything is to be changed, it must be changed by a mode or by motion; whatever comes to pass, does so by a mode, that is, in physics, by motion. Without motion or change of place, or more generally, without a change of state, no new existence, no product, no coming to pass can be conceived ; that is, nothing is capable of existence or change, except by motion. It follows, therefore, that this first simple entity, or point, was produced by motion ; and since the cause of production is in the Infinite, it follows also that this simple or natural point, was produced by motion from the Infinite.

5. If then it is admitted that the first simple was produced by motion from the Infinite, we are at the same time bound to suppose, that in the producing cause there was something of will ' that it should • be produced ; something of an active quality, which produced it; and something intelligent producing it thus and not otherwise, or in this particular manner and in no other; in a word, something infinitely intelligent, provident, powerful, and productive. Hence this first point could not come into being by chance, nor by itself, but by something which exists by itself; in which something there must also be a kind of will, an agency, and an understanding that it should be produced thus and no otherwise. There must likewise be some foresight, that the product should be successively modified in a particular way and no other; and that by this series, certain particular results, and no others should arise. All this must of necessity have been in some way present in this first mode and motion : for in this particular and first motion of the Infinite, things future and coming to pass can be considered in no other way than as if they were present and already in existence.

6. Since, therefore, we have traced the origin of the simple, or first point, to the Infinite, from which it is derived by means of motion, we may now define it thus :—That it is a simple and first entity, existing from the Infinite by means of motion ; and thus that, in respect to existence, it is a kind of medium between what is infinite and what is finite.

We shall now proceed to consider and explain, distinctly and particularly, whatever concerns the origin of the first point, together with its attributes and essential properties.

7. Let us return, for a few moments, to the positions already advanced. With respect to the essential of the first simple, I maintain, that this natural point is the same as the mathematical point, or the point of Zeno. For the world is geometrical or mechanical; nature modifies itself by the laws of mechanism, which are its own laws ; wherefore the the same beginning is to be assigned to the world, as to geometry. The same point is the first of the world, because it is the first of geometry ; or it is the first of geometry, because it is the first of the world. Geometry is the law and essential attribute of every individual substance in the world, or of the whole world ; and mechanism is the mode by which the world acts or is acted upon; hence the point is common to both, because both flow from the same origin. Thus each acknowledges a certain entity existing before itself, and outside of itself, which it considers as a kind of seed, from which it was conceived, and by which it afterwards exists and subsists. Since, therefore, both geometry and the world are derived from the same origin, the same seed, and the same parent, we must conclude that they both proceed from the same point, the difference consisting in this, that the latter point, or that of the world, is called the natural point, while the former, or that of geometry, is called the mathematical point.

8. This point is a simple entity, and indeed so very simple, that nothing can be more so, because that which is simple



admits of no degrees. The Infinite itself, from a geometrical point of view, may be called an entity, yet only in an eminent sense ; but that which first exists by motion from the Infinite, becomes an entity because its essence consists in motion. ^It" cannot be said of the Infinite that it is the first simple ; for there is a great difference between what is infinite and what is simple ; the one being the cause, and the other the effect. That which is simple, as it has one limit, cannot be the cause of itself, but must acknowledge its cause to be in-another, which has no limit, and which is the cause of itself. Therefore, if they are distinct in themselves, one must be prior to the other. Neither can the same be predicated of the simple as is predicated of the simple of the infinite; nor the same of the simple, which may of the infinite; wherefore this first product of the infinite must be that simple entity, which is to be acknowledged as the first simple of things finited, and as the cause of the first limit among such finites. Nor can it be a finited simple; for this must consist of two boundaries at least, without which it cannot be called a finite : but this subject will be more fully discussed in our next chapter.<sup>1</sup> That it is, therefore, a simple, appears from this, that nothing can exist in a more simple state than that which primarily and immediately proceeds from the infinite, and which first exists in the infinite, prior to the possibility of its existing in any finite, or among things finited ; also that it is the origin of the first boundary of the finites, from which all others are afterwards successively derived. Now since composites acknowledge their origin to be in some simple, and since nothing can exist of a more simple character than the point of which we are now treating, we conclude, both from the consideration of its existence from the infinite, and from the existence of things finited by it, and also from the nature of the thing regarded in itself, that this point must be a simple entity.

It follows, therefore, that it is in no respect compounded,

<sup>1</sup> Chap. iii. ; prop. 9.—*Trs.*

finited, or limited, because it is simple; except that it may be said to have only one termination or limit. Since it cannot be denied that a simple entity ought to be considered as the origin of entities not simple ; that there must be one limit before there can be two ; one boundary before several; it must also be admitted, that a relation between such boundaries first exists, when one is succeeded by another. But if the one which precedes another is finited, and 'if it contains within itself several smaller boundaries, it follows, that there is no final ratio nor can there be, except in that which has one limit only, and that it exists before the first substantial or finited boundary. When therefore two things are given, one must be given ; when several limits are given, there must be one limit; in short, according to all the facts of the case, wherever there is a finite, there must be something not finited ; wherever there is a composite there must be a simple ; wherever there is a body, there must be a point of that body ; and since there must be such a point before there can be limits, boundaries, and a body, it may hence also be said to possess one limit. Nevertheless this point has in itself something analogous and similar to what exists in things limited, because it consists in motion ; and although pure motion does not necessarily require anything substantial as the basis of its existence, there still pertain to it both form and space, which are attributes of motion. And thus there must dwell in the point some relation of figure or space to its motion ; or to whatever is analogous or similar to motion in it; this entire analogy or simple relation makes up the essence of the point.

9. Since this point has only one limit, it follows, that it is the first entity and seed of things finited. The Infinite cannot be said to be the first entity and seed of things finited, except so far as it is their cause, and the efficient power to bring them forth; such a first entity must be produced from the Infinite, in order to be of the character here intended. Every seed must acknowledge its author, its

producer, or cause of its production ; for it cannot be self-produced : it must, therefore, acknowledge Him to be its author, who exists of Himself. Hence it cannot be said that the Infinite is the first seed of things finited, except so far as it is the cause and efficient producer of such an entity and simple point, or so far as something of infinity is admitted to enter into the pure motion of this entity and simple point.

10. Nevertheless this point is a kind of medium between the infinite and the finite. For it is, through the medium of this point, that finite things exist from the Infinite. This point is a medium both as to existence and as to origin ; for it first originates from the Infinite, and then gives origin to things finite. On the one hand it acknowledges the Infinite, and on the other the finite ; thus it stands between the two, and looks as it were both ways, having respect as well to the vast Infinite, as to the vast finite; and in reference to its existence, may be said to participate in the nature of both. It may be compared to Janus with two faces, who looks two ways at once, or at both universes. On one side is the pure Infinite, into which no human mind is able to penetrate, or in which it cannot discover either a least or a greatest, both being completely unknown, and of themselves identical; on the other side is the finite alone, to which we may have access, through the medium of this point, which partakes in a manner of the nature of both. By this point, as by a door, we are introduced into the world; we are admitted into a kind of geometrical field, where there is ample scope for the exercise of the human understanding. As soon as, through the medium of this point, an entrance is found into the finited universe or the world, man instantly begins to have a knowledge of himself, to perceive that he is something, that he is finited, mechanical, and even a machine ; that is, by this point we are introduced into the world, and into its law, that is, into geometry, which could have no existence prior to the existence of the point. Nature itself

also commences with this same point : to this it is indebted for its birth, that is, for its conception and birth ; and from this it first receives what may be called its life, and its forces under their several modifications. Wherefore the world begins with this point, and with the world nature itself; or, nature begins, and the world with nature. On these grounds this point may be said to be the medium between the Infinite and the finite.

11. This point is produced immediately from the Infinite. With respect to existence, as was said before, one precedes the other ; with respect to cause, one is the cause of the other; with respect to mode, one modifies the other, this other not being capable of existing without a mode ; and with respect to subsistence, one subsists from the other. Now in relation to existence, it is evident from reason that the Infinite must have existed before the point; in relation to the cause, that the Infinite must have been the sole cause of motion in the simple or in the point; in relation to mode, that the Infinite, by means of motion, must have produced the first simple or the point ; and in relation to subsistence, that all finite things, thus produced, subsist from the same cause and mode. Since, therefore, the Infinite in respect to existence precedes, it follows, that as an antecedent power it might have existed, and might still exist, without such motion as that above supposed. And since it was the cause of motion, it follows also, that it was in its power either to be, or not to be, the cause of such and such a particular effect. Similarly, since motion was the mode by which the point came into existence, there can be no mode in the Infinite, unless indeed the will that something should exist by a mode be so called. Therefore, since all finite things, which exist by such a cause and mode, are in their nature distinct from the Infinite, it follows that the first motion, which is the essence of the point, was immediately produced from the Infinite. We cannot say that the essence -of the Infinite consists in motion, motion being rather the

offspring and production of the Infinite, and indeed its immediate production ; unless perhaps we indulge the thought, which nevertheless is evidently outside the sphere of reason, that the motion, which takes place in the point thus immediately existing from its source, is afterwards inseparable from the Infinite, because there is motion in the universal Infinite; in which case we may infer, that such motion, although it is not the essence of the Infinite, is yet not inconsistent with its essence, because it manifested itself in this manner.

12. This natural point is pure motion in the whole Infinite; and consequently it is pure and total motion, a motion which cannot be thought of as geometrical. When we lay down the position that the first motion exists in the Infinite, it is absolutely necessary that such motion should be considered as pure and total ; there being nothing which is capable of bounding it; nothing, by reason of which it may be said to be mixed ; nothing which admits of degrees ; so that it cannot therefore be thought of as velocity. All motion which is mixed, or which is bounded by degrees, supposes something substantial, capable of motion or of modification ; but the motion of which we are now treating cannot admit of any such thing, because it belongs to the Infinite, and exists in the infinite; for which reason also, in consideration of its producing cause, the motion must be supposed to be pure, and incomprehensible by the powers of geometry. But as it is not strictly geometrical to say that there can be pure and total motion, when no such motion is found in things geometrical and finited, a doubt on the subject may possibly present itself to the reader's mind ; yet if you will grant, what indeed cannot be denied, that there is an Infinite Entity, and that finite things were produced from the Infinite, what other conclusion can be rationally drawn from these premises, than that a first mode did exist ? And if so, reason dictates that it could exist only in the Infinite, and not in any finited medium. Hence, if it be granted that the Infinite is a

producing cause; and if a mode or motion, as an effect produced, be likewise granted; then it must also be conceded that there is a pure and total motion. For that which alone does or can occasion the motion to be not pure, and not total, but mixed, is the finite itself, which, according to our hypothesis, is not yet in existence. Therefore, since this motion must have existed in the Infinite, and before the birth of finites, it follows that it must also have existed before the world, and before its established laws, that is, before mechanism and geometry; thus it cannot be thought of geometrically, but rationally. And though we cannot think of such motion as geometrical, we are not to conclude that it is nothing; although it has no relation or analogy with finite motions.

A simple cannot be thought of geometrically ; yet it is not on that account nothing. The Infinite cannot be thought of geometrically ; yet it is not on that account nothing. A finite, in respect to the simple, is as nothing. A finite, in respect to the infinite, is nothing, because there is no ratio between the finite and the infinite; which is the reason why it is said that what is finite is nothing in respect to the infinite. Still, however, what is infinite, pure, total, and simple, is not to be regarded as nothing; although respectively it may equal nothing, and thus cannot be geometrically conceived. Rationally speaking, if there be a composite, there must be a simple; if there be anything extended, there must be something not extended; if there be anything mixed, there must be something pure; if there be a part, there must be a whole; that is to say, if there be a mixed and partial motion, there must be a pure and total motion. Pure motion may therefore exist, but not in space, or in a medium consisting of finites, or among finites.

13. This motion presupposes nothing substantial by which it may be said to exist. In the Infinite there is nothing substantial, nothing capable of modification, as in finites. But since motion is not inconsistent with the Infinite, the

Infinite may be considered not only as the cause and producer of it, but also as eminently its modifier. Hence, as there is in the Infinite nothing substantial to be modified, there is no motion but what is pure.

But since pure motion exists neither geometrically nor mechanically, it must, therefore, be of such a quality, that neither degrees, nor momenta, nor anything of velocity can be assigned to it; all we can say of it is that such motion actually exists in the whole Infinite. Yet the Infinite is utterly incomprehensible ; hence an idea of this motion as existing in the Infinite becomes still more incomprehensible. For if you were to multiply the greatest finite, or the whole world, by the infinite, the result would be nothing, since no finite, whether considered particularly or generally, bears the smallest proportion or ratio to the infinite; but everything finite vanishes by the comparison, or becomes nothing. How then are we to conceive of this purity and totality in motion ? Certainly in no other way, if geometrically and rationally understood, than as an internal state or effort toward motion. For if in the whole motion there are no steps in space, no moments in time, and thus no velocity ; and if again there is nothing substantial, as before observed ; what else, according to every human notion or idea, can result thence, but effort ? When we understand space simply as it is, and consider motion as pure and apart from time, in such case the motion must be instantaneously present in every part of its own space; and thus it will be like effort itself: for in effort not only is motion everywhere present, but with it also its force, direction, and velocity. This effort towards motion may also be called internal state.

But to prevent any confusion or misapprehension in our ideas concerning motion, effort, and state in the simple, which, as hitherto used, appear to be mere terms, entirely apart from, and foreign to, every law of geometry, so far as they are said to belong to things simple, I will now endeavour to explain the subject by means of geometry,

figures, and compounded motions, and thus in some measure fix our ideas. For example, let us suppose the parts or minute particles of a body, which are perfectly alike, to be moving among one another; and let us further suppose that the cause of the motion is within each particle; it will hence follow, that by continuing their motion for a sufficient length of time, they will be brought into a situation conformable to the motion and figure of each, when they will begin as it were to link themselves together ; and in this state they will be found to be in the situation suited to their peculiar motion, which situation is that of the whole composite body, or its internal state. But the cause of motion, since it remains in each individual particle, and no single particle can be moved without all being moved together, therefore becomes common, and pervades the whole; so that by reason of it all strive and conspire together to produce one common and unanimous motion. This is what we mean by effort. Thus we have first the motion of each individual particle; then the state of all together, which is the internal state; and thus effort.

Let us now return to things simple, and see whether, by the aid of the motion, state, and effort in geometrical substances, as just above described, we can form any better conception of the motion, state, and effort, which take place in things simple. In a simple there are no parts or individual corpuscles which can be moved : but since there is in it a cause of motion, as before observed, we must, therefore, form an idea of motion without parts or individual particles, like an effect from its cause; and this can be thought of in no other manner than as a pure and total motion. Hence there can result no disposition of parts, nor can any other state arise by means of position, than such as is inherent in that perpetual motion ; consequently, neither can there arise an effort from any other source than motion. It follows, therefore, as motion is destitute of parts, that motion, internal state, and effort in the simple, may be considered as one and the same thing; when yet in finites they are different from



one another, because in these there is a motion of the parts, and consequently a mixed motion. But if the reader still doubts, and does not yet comprehend what motion is without something substantial, or what is meant by pure and total motion in the simple, I would observe that it is its state. Should this appear equally to require explanation, I say that it is its effort leading to a kind of motion; and if this be not satisfactory, then I add that it is all these taken together. I cannot give a clearer and fuller explanation of the interior nature of the simple, unless indeed the following may be so considered—That in things subject to geometry there can be neither state nor effort without motion ; similarly, in things that are beyond the reach of geometry, that is, in things simple, there can be neither state nor effort without motion ; yet there is this difference, that in things geometrical they are distinct, and one is the cause of the other, while in the simple they are not distinct, but one is coexistent with the other, and all together present one simple mode, and constitute a simple entity.

14. This point cannot be conceived as having extension ; it is without parts, and consequently indivisible. If there is in the point nothing substantial to be moved; if the motion is pure, not mixed with anything substantial, and not arising from it; or if there is an effort tending to motion; it follows that it must be destitute of parts, there being nothing of the kind in such motion or effort; for parts presuppose the existence of things substantial put into motion, of which they necessarily consist. If the point be without parts, it must also be indivisible ; for to divide would be to annihilate it. In respect to its own motion, it may be said to have a kind of extension ; but, considering that there is nothing substantial in it that can be moved, that it cannot be divided without annihilation, that it has only one limit, and is thus a simple, it must be pronounced to be without extension. ' For everything limited originates from something not limited ; every thing finited from something not finited, or from a simple; every

thing extended from something not extended ; just as numbers arise from unity, and unity from what is least in our conception, or next to nothing.

15. Neither can it be said to fill space, unless it be space understood as simple. If the point has no extension, but is of such a quality as to give rise to extension, it follows also that it does not occupy space, unless it be space understood as simple. For since it possesses only one limit, because it is a simple entity, and this one limit includes no space, it cannot, in reference to things finited and variously limited, be said to be a space ; but in respect to that pure motion, from which it originates, something of space may be attached to it in idea ; yet only by analogy, and in the relation of an attribute.

16. The point cannot be said to be endued with figure, unless the figure be understood as simple; and this can only be comprehended by a certain analogy and similitude, which it bears to its own motion within itself. As its space must be understood as simple, so likewise must its figure ; for of whatever kind is the space, of such is the figure, the quality of the space consisting in the figure. Now since the space must be conceived as simple, and considered as a limit or as one boundary to finites, in the same manner also must the figure be conceived ; that is, in respect to the figures of finited spaces it must be understood as simple. For the largest figures, which we will suppose to be circular, have many or very extended points of contact; smaller figures have fewer or less extended; and the smallest or simple figure may be said to have the smallest points of contact, or such points understood as simple ; and thus it may be called a simple figure. As for example, let us imagine innumerable circles round the same centre; and let radii or diameters be drawn at every angle from or through the centre, cutting all the circles ; the greatest circle will then give the largest arc to the angle ; the smaller circles, or those nearer the centre, will give smaller arcs; and the circle nearest the centre will give the least; but the centre itself will give none. Still however a

conception must be formed of its figure, by analogy, with reference to its effort or motion ; for motion creates space, and consequently figure ; motion cannot exist without space and figure; and whatever there is in motion is present also in effort. Yet in itself, and in respect to the motion of which it is composed, something analogous and similar to what exists in things finited must be conceived.

17. Figure thus conceived is most perfect. Since effort may be contemplated after the manner of motion, whatever is in motion is also in effort; and since there is nothing in motion which did not previously exist, and is in effort; therefore, instead of the term effort, we shall in the following pages substitute pure or total motion. Nothing then can be more perfect than the figure which is produced from the purest motion, and which exists in the Infinite. And if such figure be most perfect, all entities of a like kind must also bear an entire resemblance to it. In the Infinite there is nothing unlike itself; nor is there anything of dissimilarity in pure motion. Dissimilarity is produced by limitation, by the blending and conjunction of several things ; also by multiplication, division, geometry, and the mode or modification of similar things. For the more an entity is modified, so much the more is it rendered unlike another entity ; dissimilarity increasing in the things modified in a continual series. Since then this first point is not yet modified, and since it derives its origin from no other source than from the Infinite, and from pure motion, nothing of dissimilarity can be supposed to enter into it; for all dissimilarity, whether of the least or greatest degree, is produced by modes, which multiply in series, and which increase in succession.

18. In respect to quantities, or when geometrically considered, this point is as nothing, or escapes the imagination. For although it is the origin of so many and such great finites, yet in things finited and geometrical it will be equal almost to nothing.

19. Nothing can be ascribed to this point, which is ascribed to a composite, except by way of analogy ; seeing that it is absolutely simple, unmixed, pure, and the first primary. But since it is of such a nature, that it must be contemplated as immediately proceeding from the Infinite, and yet existing before any finite, and so must be considered as non-geometrical, although it resembles what is geometrical, inasmuch as the latter is produced by it, like always begetting its like ; I could wish that some other person, capable of the task, would favour us with a better idea of the subject. For my own part, I would willingly give up further consideration of the first entity, to which something of infinity adheres, and proceed to the finites treated of in the following sections, in which the point will be found to be more clearly elucidated ; but to prevent any interruption in the thread of our principles, we will for the present continue the enquiry already begun. Let it then be observed, that whatever is present in effort, and does not yet exist in act, cannot be termed geometrical until it so exists ; but still in every entity exerting an effort there is something similar to geometry, and to actual motion.

20. In its pure and most perfect motion are contained all those things, both active and passive, which bound things finite, and continue to do so throughout all their series. That the essence of the point consists in motion was observed before, and will presently be more fully illustrated. Now since its motion is most perfect in its nature, since it has the power of creating something very like itself, and since from this point all finite things originate, therefore it must also contain everything finited, and everything which exists through a long series of finites, both actively and passively. For since it is the one only entity which gives existence to finites, there must be included in its very effort and motion everything that is modified throughout any series, or that is capable of still further modification, together with all the properties of self-modification, such as we find actually existing in the world.

## *THE FIRST NATURAL POINT.*

For unless the point or simple consisted in an effort toward motion, and also in motion actually produced, nothing could be conceived to be in it that is efficient, active, and productive ; there would be no cause in it that could produce any effect, any active or living power ; and yet it is in real actual motion alone that the cause of all existence lies concealed. If a simple were imagined to be void of all internal motion, it would be something inert, or a mere atom, of itself altogether passive; nor could anything new ever exist or spring up amongst such inert substances or atoms, unless indeed an extraneous motion were immediately introduced among them, which yet must have its cause in some active entity. For if this simple produces anything, and if it is something active which produces, then there must be motion, and this motion must be in the point itself; that is to say, there must be, not effort, but action. If any one were disposed to represent the first simple as destitute of internal motion, he must in this case stop short at this first simple, and finite the whole world in that simple and its atom.

21. We now come to inquire analytically into the nature and quality of the form of this simple point, and into the nature of its space so far as it has respect to motion. For if there is effort toward motion, there must also be form, there must be space, and other attributes and essential properties, which, according to geometry, belong to motion.

Since this motion, in which the point consists, is an effort toward motion, or what amounts to the same thing, since it is pure motion, not existing in any medium of finites, but in the Infinite, its form must necessarily be absolutely perfect. Pure motion, or motion in the Infinite, cannot produce anything imperfect, or unequal ; but whatever is produced by it must be absolutely uniform and perfect. If the form of the motion is absolutely perfect, it must necessarily resemble a circular form, for there is nothing in the nature of finite things more perfect than this. But since the point consists purely of motion, so that this point, and pure motion, and an

effort towards motion, are one and the same thing, it follows that motion must exist everywhere in the point. If an absolutely perfect form is circular, then the absolutely perfect figure of the motion above described must be the perpetually circular ; that is to say, it must proceed from the centre to the periphery, and from the periphery to the centre. If therefore the motion be perpetually circular, from the centre to the periphery, and reciprocally from the periphery to the centre, or if it be equally diffused throughout, it must necessarily be a spiral, which is the most perfect of all forms. In the spiral there is nothing but what partakes of a certain kind of circular form ; and nothing within it is put into motion but what takes a circular direction. The motion advances perpetually to a circle. The spiral motion may be said to be infinitely circular ; every motion round the centre is a circle; its progression towards the periphery is circular; in a word, in all its dimensions and in every sense it is circular. Perpetual circulation is like a perpetual spiral; hence the most perfect figure of motion, as well in effort as in act, can be conceived to be no other than the perpetual spiral, winding, as it were, from the centre to the periphery, and again from the periphery to the centre ; thus it is a flowing spiral motion continually returning upon itself; which is not only the most perfect of all figures, but also the best adapted to the nature of finite things.

If we suppose the most perfect figure of motion to resemble the perpetual spiral, and the point to be a perpetual effort toward the spiral motion, and thus the most perfect and uniform entity, it follows from the likeness, which may be traced between it and things subject to the laws of geometry, that it has a centre, and also peripheries, or a centre with unlimited peripheries. This motion must therefore have its centre in effort, and it must have a periphery. These may be considered as the attributes of a motion perpetually spiral and returning upon itself, or of one which occupies space from the peripheries to the centre. But since this internal motion in

the point and its figure can be understood only in the way of analogy and resemblance to the things which exist in finites, its mechanism can be more satisfactorily illustrated from the finites to be treated of in the sequel.

Seeing then that it is a pure motion, without anything substantial to move, and that it flows into the spiral, or perpetual gyres and complete circles, we cannot conceive that there is in the point any such actual flowing out and in, from centre to periphery, and back again, as there is in finites, but only an effort tending to such motion, and a figure very like it. Now as pure and total motion, or effort, admits of no degrees of velocity, but generates from itself the first degree, moment of time, and limit in velocity, that is, generates velocity not yet brought forth into act, therefore it cannot be said that such motion flows from the centre to the periphery, unless it be understood that it is in the centre and in the periphery at the same moment, and thus instantaneously present in every part of its space. Hence, if we would amuse ourselves by a play of words, we might say, in regard to the point, that its motion is in the centre when it is in the periphery, and in the periphery when it is in the centre ; thus that it is all centre, and all periphery ; or that it consists, as it were, of perpetual peripheries; and that, with respect to the presence of its motion, the centre and the periphery are in a manner one and the same, both together constituting this point.

But geometry can neither express the effort toward this motion, nor describe its figure, except by similitude. It is incapable of giving any demonstrations ; for while it is within this point, it acknowledges itself to be not yet finited, not yet, as it were, put forward, or brought forth, in short not yet anything, but only about to become something ; and in this state it lies as it were in embryo till matured ; that is, it cannot as yet be analysed by finite terms or limits, which nevertheless successively arise from this ovum. Since therefore this point can receive no adequate geometrical demonstration, we must have recourse to the principles and axioms of rational

philosophy, and instead of the point substitute an entity, and so proceed to its investigation by the attributes proper to such entity. Now if we take a rational view of this metaphysical entity, we shall find it to be of such a nature as to consist of only one limit; it is not properly limited ; it is not finited ; but it is that from which things limited and compounded are derived. It is a something which cannot be geometrically resolved ; it is that, to which, and beyond which, no science can possibly extend. It is simple ; and yet, being of a productive nature, it is active, consisting in effort toward motion ; which motion, were it to take place, would be pure and total, or the same and everywhere present as it is in the effort. In this lies concealed all that quality which is capable of bringing into act finite things, together with all their modes and contingencies, and even of producing the world itself. Thus, unless motion were in potency and in effort, it would possess no power or ability to bring into act those things which are really produced, and which together constitute the world.

22. But while there is merely an effort towards motion in the point, we have as yet nothing actual. Inertia, force, and effort, without motion in act or effect, is like something inert, passive, and dead ; which, by means of local motion, or the transition of effort into act, becomes active, living, and efficient; thus from a mere cause it becomes operative. It is with great propriety, therefore, that we inquire, what is the nature of that effort ? In other words, into what kind of motion, or into what figure of motion, has such an effort a tendency to put itself forth, if there is no obstacle in the way ? For it is well known, that in effort there are present both force and determination, direction and velocity, with all the essentials as well as attributes of motion. Therefore, before anything can be produced, effort must pass into act, like what is formal into what is real ; and consequently the point with its effort must so pass into motion. Since then total motion, or that which is internal, tends to a figure most perfectly and purely



mechanical, that is, to the spiral, we hence obtain an idea of the internal state of the point; by which internal state we perceive the quality of the effort as it presses forward into external motion. The real determination and direction of active or local motion is solely owing to the figure by which this effort exists. It was before observed, that the figure is perpetually spiral, proceeding from the centre to the periphery, and reciprocally from the periphery to the centre ; by and according to which form it is inclined to direct every effort, and, as it were, to aspire to active and local motion. For if there be an effort tending to motion, and if a similar quality exists in effort as in motion, there will exist by similitude, figure, and space. For example, if there is an effort tending directly from one extremity to the other, a rectilinear motion will ensue in that direction ; but if the effort, by the form which it assumes, revolves round some centre, in this case a circular motion will be the result. But not only is motion determined into form, it is also directed by effort ; and thus whatsoever does or can exist in motion, is previously to be found in effort. The form, therefore, in effort, of which the simple consists, is spiral, in agreement with what has been already advanced. From the form we may now conclude as to the kind of motion into which the effort runs.

I say then, from the mechanism and geometry of the internal spiral motion there arises first a kind of axillary motion; afterwards a progressive motion of all the spirals round their poles; and lastly, from the axillary and progressive motion, if there is full liberty, and there is no contact, another or local motion in agreement with the former, and indeed tending into perpetual surfaces. But as these subjects cannot be geometrically treated, and still less demonstrated, without having recourse to some finite body or particle, consisting of parts and individual substances, and in which those parts and individual substances become arranged into a position and a spiral form, like those which the effort assumes in the point; so by the method here proposed we shall be

able to obtain a mechanical and ocular demonstration, that such an arrangement or disposition of the parts or individual substances begets and produces not only a common axillary motion, but also a progressive motion, conformable to the position and series of the spirals ; and in addition to this, provided there be full liberty, and no contact hinders, a second or local motion, by which the surfaces are traced out. As the point consists not of parts, it cannot so well undergo geometrical examination, explanation, investigation, and dissection, we shall, therefore, proceed to the consideration of finites and actives, in which the mechanism of the same motion will be gradually presented to view. We shall afterwards demonstrate by experience, and likewise by the laws of mechanism, that in the point, or in the effort of the point, lies concealed the whole power, both active and passive, of mechanically producing, in just order and in regular succession, all finites whatever, or the world at large, both with respect to its smaller and simple parts and its greater and composite ones. Geometry, therefore, and mechanism, in relation both to the parts and to the whole of a body, and also in relation to the world itself, consists in this, that the first figure of motion, state, and effort, is spiral ; and that by virtue of such a figure there succeeds a motion of the whole composite, or an axillary motion ; a motion of its parts, or a progressive motion ; and lastly, from these, a local motion. Such is the sum of our whole work and of its principles; and such the cause of all the parts and composites in our mechanical world.

23. As the subject here treated of is the point,.. or the simple entity of things natural, we cannot in proof of our theory adduce any experience and confirm our principles by it. In subjects so extremely minute and simple we have no experience and no phenomenon ; no motion presents itself to our senses, until we betake ourselves to things variously finited and much compounded, and thus to a series of composites connected with one another, which, taken collectively,

represent our world ; and thus exhibit their phenomena in a way adapted to the mechanism and connection of finite entities, yet not by simple, but by variously compounded motions. On the present occasion, therefore, while treating of the point, nothing in the way of experiment can be produced by which the truth of our principles may be confirmed or tested. We can only observe, that nature, which is a motive force, has neither the tendency nor the capacity of flowing into any other figure of motion more freely than into the spiral; by which figure also its whole velocity is conveyed with the greatest freedom and facility through all its gradations ; and to which, in like manner, it appears to have applied all its mechanical energy and power.

24. Still, however, it follows from reason and experiment, that motion is the only means by which anything new can be produced. Motion itself, which is merely a quality and a mode, and nothing substantial, may yet exhibit something substantial, or the resemblance of what is so, provided there is anything substantial put into motion. If any small body is moved in the direction of a line or a circle, there is immediately produced by the motion the semblance of a line or a circle ; although there is nothing substantial in it, except that small body in the place which it occupies. If the motion were to proceed in a spiral figure, or by continuous spires spatially from the centre to the peripheries, a body of a round form could then be imagined ; and yet there would be nothing substantial in the whole of this space, except the single particle, which makes all that space to be substantial in which it moves, or where it is present. If now the motion be very rapid, so that in a moment the body is present in innumerable places, during that moment it makes all that space substantial, wherever it is present. By motion alone, therefore, something resembling what is substantial can be produced, and it cannot be produced without some other means. Motion itself represents something thus multiple and aggregated ; and there would also actually be a multiple or

## *THE FIRST NATURAL POINT.*

aggregate arising solely from motion, were not moments of time present in the velocity. If now the times of velocity were the least imaginable, the least would also be that which would distinguish such a kind of substantiality or modification from a positively substantiated form, owing its existence to an aggregate of small bodies. On this account also geometers suppose a point to be the origin of geometry; from this point they derive their lines, areas, and solids ; but they add also a motion or fluxion of the point or points. They consider a point without motion to be incapable of anything, however small, toward the production of a line, because the point is destitute of length and breadth ; but by its motion they can form every dimension of a body. In the differential calculus, or the analysis of infinites, they likewise avail themselves of a kind of fluxion, from which they obtain their figures, and the relative proportions of those figures. In a word, it is a natural or physical truth, that things finite are generated by fluxion and motion, and that without this nothing which is the subject of geometry could exist.

25. Seeing, therefore, that we are now brought to the consideration of finites, and are, as it were, introduced into the mechanical world, I propose in the following pages to proceed to the exposition and demonstration of our principles in the following order. First to explain for what reason and in what particular manner a posterior finite, entity, or particle, derives its origin from a prior one, whether by motion or by any other mode and contingency. Then to give a definition of the entity, finite, active, or particle, both in general and in particular terms, also to examine in a circumstantial manner, as we did in relation to the point, all the attributes, essential properties, motions, figures, spaces, and other qualities, belong to that entity. After this I shall take a geometrical view of the subject, and endeavour to see how far we may safely indulge in philosophical reasonings and arguments concerning this entity. Experiments will be adduced as witnesses, if any are to be found ; by which means we shall be able to ascertain

whether the truth of experiment does or does not accord with the truth of geometry. For a thing may be geometrically and mechanically true, but may not yet be confirmed by experiment. There is a geometrical connection of finites even in worlds quite different from one another; but still the same phenomena do not therefore exist in all; for there may be various kinds of geometrical connections, while only one kind is adapted to the perfection of one and the same world. Lastly, I will show the connection of every finite, active, or elementary particle, from its first point and origin ; so that it may be evident whether or not ends and means bear a mutual respect to each other and in what manner.

Having no other end in view, and being influenced by no other desire, than to be able to arrive at the knowledge of things by the most simple and correct method ; in order to discover truth, I do not see that we are at liberty to pursue any other course than first of all to lay down our philosophical principles, and then to explain them, particularly in reference to the very small and most minute parts above referred to ; that we may be able to discern the nature of their form, motion and other modes and attributes, together with the true cause of their origin and existence. After this we shall add an analysis of the whole, that we may see more clearly whether all the particulars do or do not separately and distinctly square or coincide with one another; that is, whether or not our principles are capable of receiving fuller evidence and demonstration. We shall then proceed to experiments, or to phenomena, by which nature in a manner renders herself visible to us, and presents to our view her ultimate figure or external features. Hereby we shall be enabled, to see whether the principles which were at first the work of imagination, and afterwards found to be geometrically true, are also confirmed by actual experiment. Lastly, I shall endeavour to trace the connection between preceding and subsequent principles when they are thus geometrically and experimentally exhibited before us, in order that we may

thereby discover whether anything new is produced which did not previously exist; and also whether all things proceed in successive order geometrically and physically, and thus necessarily from the first entity. If this course and method is pursued in our endeavours to find out the laws of our world, it may be fairly presumed that we are treading in those steps which alone can lead to the discovery of the secret things of nature. Yet, should any person perceive in the principles here laid down only what disagrees with experience, or with analytical geometry ; or should he be able to point out anything imperfect or defective in them; if he will have the kindness to communicate the same to me, I shall receive his hints with gratitude. For truth is but one. Truth is my single aim ; and if any friend will educe from his treasury of knowledge a juster and truer representation of the subjects in hand, his kindness in so doing will be esteemed a most acceptable service. Since then nature can be searched out in this and in no other way; and since we are admitted into its interior recesses by this, and by no other gate; on these grounds I hope for the favourable opinion of the critical reader, who, I trust, is inclined to direct all his attention to this simple entity, and to enter fully into the discussion of the first natural point and to look leniently upon the things he would criticise. But let us proceed in due order with our work ; and I have no doubt the subject—this natural, point—will receive additional illustration in the following pages.

## CHAPTER III.

### A PHILOSOPHICAL ARGUMENT ON THE FIRST OR SIMPLE FINITE, AND ITS ORIGIN FROM POINTS.

1. Since, therefore, there is interiorly in the point, or in its motion, the very quality or actual power of producing other finites, and indeed, in succession, all those which collectively form the world, it follows, that from the points or simples, mentioned in the preceding chapter, this simple finite or first substance is produced. For this simple finite must derive its origin from points ; it cannot derive it from any other source. For it cannot exist from itself; it must exist from other things which are also more simple than itself ; and since there exists in the universe, as yet, nothing but a point, it must consequently be produced from points. This I call a simple finite, because it is the first finite. Moreover, it cannot be finited and limited by itself; it must be so by other things in which there is a power of Uniting; it must, therefore, be finited and limited by points. Consequently, it derives its origin from points, which, as we have said, are the only things yet existing in the universe.

2. Nor can any finite originate from points, except by means of motion among the points. Without motion nothing is produced. In physics, every mode consists in motion. Every thing that happens takes place by a mode or modification. Every modification supposes something that is moved. A finite, therefore, must originate by means of the motion of points among one another.

3. But the motion among the points must also have its

cause. Motion cannot exist among the points immediately, and in this way produce anything new. The cause of motion must be solely in the simple or point itself, that is to say, in the internal motion and state of the point. We must not, therefore, seek for this cause anywhere but in the point, and its active force as acquired by its own internal motion or state. Whatever happens which occasions the points to move among one another, and, when put in motion, to produce something new and finited, depends also itself upon the first cause of the existence of the points, and upon the points themselves. The entire cause of motion, therefore, among the points must be in the point itself. Nor can it come from without, where there is no cause; unless this cause is something separated ; and in this case the cause of motion would have to be most remote and at the same time immediate.

4. How it is that a spiral motion in a point possesses such capability and force, we shall explain in the sequel. Here it suffices to observe, that the first or simple finite must derive its existence wholly from points, and indeed from motion among the points; and that this motion cannot possibly derive its own efficient cause from any other source than the motion and acting power of the very point itself. I would here also observe, that this new motion, or motion of the points among one another, and their state, must necessarily resemble a pure motion, or the internal state which is in the point; in other words, that it must also be spiral; that the centre and periphery are, as in the point, formed by a reciprocal spiral motion ; and that in its finited boundaries it resembles the motion and state in the point, so that like begets like. These observations we have premised in order to define the simple finite ; their truth will be further deduced and demonstrated in the sequel.

5. The simple finite, therefore, may be defined, as being the first or simple finited entity deriving its existence from the motion of the points among themselves; and as being thus the first substance of all the finites.



The attributes of this finite, as also its essentials, together with its motion, figure, space, and all its other qualities, will be further developed in the sequel.

6. That this first finite is not only the first, but also the least or smallest substance, is evident from this ; that it arises mediately from the points by motion, and that it is the first among the finites. Hence it is not only a substance, but also the least substance, which is one and the same with the first or simple finite. From a pure simple, nothing can come but a first finite ; for it is finited by the motion of the simples or points; since motion is the only means capable of finiting and producing what is substantial. On this subject, however, we shall treat further in the sequel.

7. In the whole world there is no other substance than this finite. Composites are indeed substances; but they consist of parts less than themselves, or of other indivisible particles which are themselves also substantial ; and ultimately of this first substance. So that in every compound, nothing can be truly called substantial except the least or smallest substantial of which it primitively and thus solely consists. The one is dependent upon the other for existence, in order that there may be a continuous connection of the finites from one ' end to the other, or a connection leading by mediates from the first to the ultimate end. For, in regard to existence, such is the connection of the finites, that there is nothing in any finite which does not, when compounded, depend by connection upon its first substance. Should, therefore, any compounded entity be resolved into its least substance, the result of such a resolution would be this simple finite from which, in a given order, are successively derived the compositions of all the finites. With regard to their modifications and motions, it is to be observed, that because they proceed only from substantiate, they also acknowledge their first end to be in the first finite. Neither can accidents nor contingencies, by means of which modifications exist, have reference to any other end, or to

any other primary thing, inasmuch as they refer to a certain substance. I call it a substance, because this finite, being the first, is consequently the first substance. If, however, we would go farther back, or beyond the finites to the simples, we shall be able to infer, in like manner, that there is nothing in any compound except the simple ; for this first substance may be conceived as being divisible, as it were, into its simples or into points. We may also be able further to argue, that in any compound or simple substance, there is nothing but the Infinite ; because with respect to its existence and cause, everything subsists and ends in the Infinite ; so that if all first substances, of which compounds consist, were resolved, there would remain in the universe only simples or points. And were all these points resolved, then, since they cannot be divided or resolved without being annihilated, there would remain only the Infinite, such as it was before the existence of the points. We here speak, however, of the first substantial or first boundary of the finites ; for this is the all in finites, finites being nothing without it.

8. The least substantial is geometrical; it is limited, but limited in the fewest possible boundaries. This follows from what has been said, since it is the least finite ; being finited or limited in its least boundaries. It follows also that it is the least geometrical finite. Nothing is geometrical which is without limits ; for geometry treats of the variations pertaining to limits, together with the limits themselves. Geometry, therefore, begins with this first finite; whence this first is also the least geometrical finite.

9. It fills space, but is the smallest among the finites, or is such that there cannot be anything smaller. Since it is limited, it will, among finites, fill space. If there are more boundaries than one, there must, in this case, be a distance from one boundary to another, or space from one limit to another. This we cannot predicate of a point, which possesses only one limit; unless we predicate it by way of

analogy to its internal motion, on which subject we have spoken above.

It is endowed with figure, but figure in its smallest boundaries. This also follows from what we have said. If there is space, there is also figure. If the space is the least possible, then the figure which the space forms, must be a figure in its least boundaries. For a larger figure has several boundaries, since it has to be built up of several points before it is bounded ; while a smaller figure is bounded by fewer points. The smallest figure, therefore, is bounded by the fewest and least limits, just as the figure of a point, which is the most simple, has only one limit.

10. Of all finite figures the figure of the first finite is the most perfect. In the series of finites there cannot be a more perfect figure than that of the finite which comes proximately from the most simple finites, or from points, which cannot admit into themselves anything but what is most perfect, because they exist immediately from the Infinite. Now if the figure of this finite be the most perfect of all finite figures, then the figure of the simple will be the more perfect. The more compounded are the figures, the greater number of modes and variations must they undergo ; so that if they undergo several modifications, it follows, when they have been frequently modified, that in their successive degrees of perfection they differ very greatly from the first figure. With regard to the figure of this finite, what it is when it is most perfect, we shall endeavour to show in the sequel.

11. The figures of these finites are most perfectly similar to one another. One, and indeed the principal, degree and mode of perfection, consists in similarity. Since points or simples are most perfect, because they are also most exactly similar, being produced from the Infinite, from whom nothing but what is most perfectly similar can proceed ; and since these finites afterward proceed mediately from these similar points or simples, it may be said, that of all the figures of finites these are the figures which are the most perfectly

similar to one another. And although it cannot be denied that there may be some difference between these finites and between their figures, still the difference will be the least that exists in the series formed of successive finites. The difference itself arises from a series in the modifications, or in the frequent variations, of the limits. The more frequently limits are varied, the greater number of chances and causes there may be to produce difference; therefore in things much compounded, there may exist, as it were, an infinite difference ; so that, at length, all the compounds in a series of the same degree or genus may be dissimilar. The nearer, however, they are to their origin and first limit, that is, the nearer they are to the first similar entity, the first simple, the first and only mode, the less variation can they undergo, because the fewer are the causes of variation and the fewer the contingencies and modes.

12. This finite originated from the motion of the points among themselves. As nothing previously existed but a point and a simple, it necessarily follows that what immediately succeeds originates from that which precedes. The reason is, that the existence of things must consist in the successive series of entities, from the most simple to the most highly compounded. According to this law of succession, therefore, this first finite has its origin and is born from its prior as from its parent. Origins must be by motion ; without motion nothing can be conceived to originate. It must be motion which finites, and which limits. An aggregate of points cannot be finited or terminated except by motion. There is nothing but motion which gives it any certain limit or boundary; nor is there anything but motion which distinguishes points, before collecting or when collecting into an aggregate. By the accession of motion not only may such an aggregate receive its own proper and certain limits, but its own proper and certain space, its own proper and certain figure ; it may acquire its centre and circumference ; in fine, it may acquire boundaries possessing a certain and similar figure, or a figure possessing certain and similar boundaries.

Without motion, we cannot conceive any formation of a centre and circumference, nor any coherence of the parts or points in this primary, and as yet not even elementary, state. It is motion itself which ties and binds all together; which keeps one thing joined and united with another; which determines one to the centre, another to the circumference, and contrariwise; which confines them, as it were, between certain walls and barriers; a result for which we could not look, if any aggregate, consisting of points or finites, were without motion and thus inert. Whatever is without motion must be dissipated of its own accord. Were there no cause of composition, there would be no cause of coherence; that is to say, the compound would be dissolved by the same cause by which it was compounded; particularly in the present case, or in the state in which no element as yet exists to press equally on all sides, and thus by equal pressure force some entities into a particle or certain separate aggregate; and in which also there is nothing in the entities themselves to make them cohere without an elementary cause, and to form the limits of a given figure. Not only, therefore, must motion be the only bond of connection—the only means of composition; but it must be also a most perfectly similar and regular motion, which brings the entities into a certain similar and regular figure.

13. The kind of motion between the points which forms this finite is in a certain respect similar to that which is in the point itself. Although the relation between the internal motion of the finite and the pure motion in a point is one of which we cannot form a conception, it may nevertheless be concluded from analogy, that motion in a point, and which composes the point itself, is similar to the motion in this finite, or which composes this finite; that is to say, the point is composed by a condition or mode of motion similar to that by which this finite was composed. The similarity consists in this; that, in the point, motion or state is from a centre to a certain given circumference, from this circumference to the

centre, and so on continually and reciprocally ; so that, in a point, the animation, as it were, or reciprocation of motion, is into a figure similar to that which is in this finite. For since all those things which exist throughout the series of finites successively compounding themselves, even to the most gross or ultimate in the world, have their being in the motion of a point; and since a point now ceases to be by itself and begins to be in its sequent or in this first finite, it follows that the same quality must be in it which we have conceived to be in a point: that is to say, the motion in the finite must be similar to the motion in the point; there must be a similar and reciprocal motion from the centre to the circumference, and from the circumference to the centre. In a word, there must be the same kind of motion and the same state in the finite, which there is in the point; and so from the point there must be derived and propagated into the first finite, as into its offspring, the same active power or active force of producing further things. For the various things which proceed in succession from a point are themselves mediates to some further end. If anything new derives its existence from a point, then in this new thing there must be the same quality of producing similar mediates. Without this faculty there could be no adequate mediates; and much less could any other end be obtained. The very inmost connection of causes from one end to the other consists of these intermediates; that is to say, it consists in their production in such a manner that every intermediate is capable of representing one end; and this, by reason of its likeness to that which constitutes the end.

14. It follows, that this finite possesses in itself the same active force as the point; so that it is able to finite and produce the subsequent and more compounded finites; that is to say, it receives from the point its power of Uniting the sequents. For if there is a connection of causes extending from the first simple to the ultimate compound, there must be the same actual power in the subsequent

compound as in the first simple ; that is, the same active power of producing sequents. For when the more simple and antecedent entities become evanescent, in consequence of entering into the composition of the present sequent,74 then this sequent becomes, as it were, the primary end, or one ultimate end of the subsequents ; for the antecedent has no longer any subsistence except in the composition of the sequent, so that in our nascent world there is now no simple or point, but only a finite or first substance. This finite, therefore, becomes, as it were, the end of the following finites ; although, in respect to the point which preexisted, it is only an intermediate. Tf, therefore, this new finite, emerging or existing from simples, is, as it were, the new end of the sequents, then there must be in this finite the same quality and actual power of producing sequents as there was in the point of producing this finite. Thus we have the essence of the point brought into this finite; and the very same primary and latent power of actuating which was in the point, translated into this finite, and at the same time limited.

15. The first finite thus possesses an internal motion as well as the point. In internal motion alone consist the power and quality of bringing forth sequents into act; and were the first finite without this motion, it would possess no force or power, and would always remain inert; neither would it in this case produce anything in addition to itself; unless we suppose that a force came to it from some other quarter; that is to say, unless there came a motion from some cause outside of the finite. But if this motion came from some external cause, the new thing would not emerge from the point or this finite, but from some other origin which would be able always to impart motion to inert things, and which would modify itself in accordance with that series. And these causes, proceeding from this other and new origin, must also have such a connection with one another, as to be able to put whatever is compound into motion. Since,

however, any one thing which brings any other into act, or since every cause, must, together with a train of other causes, lie in one and the same ovum and in the same point, so in every instance in which we say that a thing is successively produced, it follows that a cause and a series of causes cannot consist in anything but the quality of the motion in the first point, brought continuously into the successive finites by similarity ; that is to say, they must consist in a motion which continually follows and successively accompanies every finite ; consequently they must consist in the internal motion and arrangements of the parts.

16. This simple finite must be compounded by means of a motion among the points, and the points ultimately settle into an arrangement in accordance with their motion and figure; consequently, the arrangement thus formed in motion derives its similarity, as also its quality and power of thus moving itself still further, from the motion, figure, and space of the points. If the motion, internal state, and effort in the point are the same; and if the effort, nothing hindering, passes into an act and motion conformable to itself or to its internal state, or if it presents itself as active; then there is immediately an active force among the points which is reciprocal, or in virtue of which one acts upon the other. This being granted, there is a reciprocal action among the points—an action which ends in a position in agreement with both their motion and figure. Because, however, the points are in perpetual motion when disposing themselves into this arrangement, the arrangement must be one which is conformable to the motion, and the end of the motion must be similar to its intermediates and causes. Nevertheless, because in this arrangement there remains an active force in every point, so long as the internal state remains ; and because, in the motion, this arrangement is so formed as to be suited to the motion, it follows that no other disposition of the parts can result, than such as will admit of a quality and power of moving themselves



still further, and as much as the figure of the parts will permit. Any moving body, if there are other moving bodies near it, must necessarily tend to an equilibrium, but does not arrive at it until it comes into a situation in accordance with the motion, form, and dimensions of its parts.

17. This finite is, in regard to its substance, the first boundary of all the other finites. In regard to its motion, it is the point at which the calculation of velocity begins ; and the analogies between finites cannot be reduced to any smaller boundary and measure. For since, in regard to its substance, it is the first and least substantial, it must consequently be the first boundary of all the finites. A point cannot be called the first boundary, because it is not finited. And because the first boundary among finites must be finited and altogether substantial, it follows that this finite deserves to be called the first boundary of the finites; and, consequently, that no analogies between finites can be reduced to a smaller boundary. In like manner it follows that the motion of this finite is the first order of velocity.

18. In relation to things much finited and compounded, this finite is as it were nothing; nevertheless it is a something and a finite' entity. Since it is a least substantial, than which nothing less can be assigned, it must necessarily be such as, in regard to things much compounded, must almost vanish, as being nearly equal to nothing. Still, however, it is a something, and the first boundary of all the finites. For if this finite is the nearest to the simple, it must be near to such as, in a geometrical sense, most nearly approach to nothing.

19. Hitherto we have treated of this subject from an abstract point of view and philosophically; we now come to treat geometrically of the figure and motion of the points constituting our first and least finite. We can as yet scarcely treat of it even geometrically, since it is a geometrical minimum; and nothing is as yet extant with which it can be analytically compared, and thus to which

any analogy can be found. From a first and only boundary no relation can be educed ; for a relation requires two things. Since, however, our finite is limited, we may conceive geometrically some relation between its ultimate boundaries, or those with which it is terminated. We may also conceive some relation in regard to the motion of which our finite has been said to consist.

For a variety of reasons it may be concluded *a priori* that the motion and relative situation of the points thence arising are similar to the internal motion and state of the point; or, that it is a spiral reciprocating from the centre to the circumference and from the circumference to the centre. For if every thing which exists in the finite is most perfectly finited, because it proceeds from a most perfect simple, it follows that the figure of its motion must be most perfect. If this figure is most perfect, it must be circular, since there is no figure more perfect; for a circular figure has no termination, no end, no angle; its termination, end, and angle, being everywhere the same, similar, and consequently one ; in which respect it has a certain relation to infinite perfection. If, therefore, the figure of the motion is the most perfect, we cannot conceive any which is more perfect than the circular, or more nearly approximating to what is most simple, or to the infinite. If, however, the figure be the merely circular, it cannot be the most perfect, unless it be the perpetually circular, circular from every point of view, and in every dimension; namely, from the centre to the circumference, from the circumference to the centre, and so on in continual and perpetual reciprocation. Such a circular figure is presented to us only in the spiral, which flows by continual circles from the centre to the circumferences. For in a spiral there are perpetual circles : there are circumferences at every distance from the centre ; it runs in a circular direction on every side round its centre, and from its centre towards its extreme circumference. So that, throughout

the whole of this spiral space, there is nothing but what is circular; there is no boundary, no end, no angle, but everywhere one and the same angle.

By philosophical and rational induction, therefore, it necessarily follows that if the motion of the points is of the most perfect nature, their motion must be spiral; also, that if there is motion among the points, and if the finite, which has ends and limits, exists by motion, it cannot have its ends and limits by means of any other motion than that which tends from the centre to a certain given circumference. Thus it has a limit in the centre and in every point of the circumference ; a limit in every one point of the surface, extending to every other point in the same; a distance between its points; space ; a figure limited in the most perfect manner. Similarly, it may be concluded *a priori* from principles of reason that the motion among the points is according to a spiral figure; because if the motion among the points finites any finite, and imparts limits to it, the same motion must be in every point, as also in every point there must be the same power of moving itself; for, in the space comprehended by such a motion, there must be a motion in every point or *locus* of its space. A motion of this kind cannot be conceived except in a spiral, where the motion of all the points has the same tendency into the same circle; where likewise the motion can be continuous ; so that the motion of the points may be said to be most perfectly similar both among one another and within one another.

There is nothing more regular in its motion than the spiral; by no other motion could the points tend to their limits and finite anything, without confusion and disorder ; by any other figure of motion the fluent points would become confounded before they arrived at their limit. Nor can any motion of greater potency be assigned than a motion flowing into a spiral. In no other figure is there latent a greater mechanical ability of penetrating from one extremity

to another ; of urging on anything to its destination ; and thus of continuing a motion once begun, by the exertion of the smallest possible force and effort. This is evident from the nature and laws of the perpetual helix ; which in every one of its points, and at every angle, exercises the power of a lever ; that is to say, is everywhere of the most perfect nature. In a word, if in a point and in the finites arising from it, we grant the existence of an internal motion, and of a state and effort arising from that motion, then must this motion and state, according to all sense and reason, tend into a spiral. These statements, however, are only *a priori*. But indeed they are arguments which it may be presumed will not satisfy the minds of my readers ; for we only conclude for certain reasons, that the motion must be spiral; namely, because it is of the most perfect kind and the most highly mechanical. Still the mind will not content itself with this kind of reasoning, failing as it does to assign the geometrical cause, or to explain how it is that there may exist such a figure of motion between the points; how also it really exists ; how, in the first spiral motion, there is geometrically such a force and quality that the points cannot be at rest among themselves, but must be in motion if they are in mutual contact ; and how, when in motion, they cannot possibly flow into any other figure than such a spiral as I have described. Still as the subject was to be dealt with in its proper order, it was incumbent upon me to begin by explaining it in a philosophical manner and *a priori*. In the sequel I shall endeavour to meet the desires of the reader by explaining it geometrically.

20. If the continuous motion be spiral it must be reciprocal ; namely, from the centre to the circumference, and contrariwise. It is evident, I think, that if internal motion be granted, it must, for the reasons given, be spiral. But if the spiral motion be continuous, it must be reciprocal. Without reciprocation, it could not be continuous. Nothing

can move in a spiral continuously unless it moves in such a way reciprocally. Without a return motion there is no continuous motion ; for there would be no motion from the centre to the circumference if there were no return motion from the circumference to the centre; in a word, the very continuation of motion consists in reciprocation and alternation. If, therefore, there is reciprocation, and if the motion is spiral, we cannot conceive such a motion taking place mechanically, unless a figure is conceived of such a kind as will admit of this motion and its return ; nor even then could there be such a motion and its return, unless in this figure *loci* were conceived on all sides, through which any point flowing to the surface might afterwards return. Unless there were such *loci* in the figure, one point in its motion would encounter another ; a single point would thus act as the cause of retardation and rest to another, and thus all motion would cease. If, however, there is a regular reciprocation, then on all sides in the figure of motion there must be *loci* through which the points may always return to the centre; thus there must also be a way from the centre to the circumference and from the circumference to the centre, lest one point should encounter another. If, therefore, a reciprocal spiral motion be granted, it must be granted also that, in the space thus comprehended, there must on all sides exist *loci* through which a reflux and reciprocation may take place.

21. From the motion of the points, parts, or particles, arises the natural and fixed arrangement of all. Consequently, in a finite, by reason of the spiral motion and arrangement in which it originated, there are two poles, one opposite to the other; these two poles are formed like cones. Motion always precedes arrangement. Without motion there would be no disposition of parts. It is only by motion that parts are united into an arrangement conformable to the motion and its figure. It is by motion that parts tend 'to

equilibrium. Motion, therefore, adapts the figure to the position ; as is the cause, such is the effect. It is thus that the parts remain in the position into which they ultimately come in consequence of their motion. Now since the disposition or arrangement of the parts is the form of the motion, it follows, that in this arrangement all the parts continue to move in a spiral, and exercise an effort to motion according to the internal force remaining in each particle. Already the parts have such an arrangement that they all tend similarly toward the same motion, and act simultaneously as one common cause ; so that there is no part which is not necessary, and which is not a part of the motion, and which does not contribute its own share to the general motion. One part consequently maintains a relation to the other ; the adjacent, both to the adjacent and to the remote; that on the surface to the intermediate; the intermediate to the central; the central to that on the surface ; and so on regularly throughout the circle. Hence every part is in series and connection ; the motion of one can be the motion of all as well as of itself; and this in a circle. Such a situation of the parts can be obtained only by means of the spiral. The communication and the reciprocation of motions, the circulation of whatever kind, when the parts -are brought into a regular arrangement, are obtained by means of poles ; so that there are connection, contiguity, and motion, extending from one pole to another ; so that the motion can, as it were, pass out of one pole and enter into the other, and thus pass and re-pass by continuous circles and perpetual spirals. The fact that, in such a motion or arrangement of the parts, the poles by reason of the mechanism of the motion and the geometry of the figures, acquire a cone-like form, will be explained in the sequel.

Similarly, in every finite entity, whose parts are disposed into a spiral figure, there are an equator, ecliptic, meridians, and other perpendicular circles. If there are poles, and if those poles are placed apart and enlarged into the figure of a

cone, then there will be polar circles also, the dimension of these being determined by the diameter of the cone. If there are cones and polar circles, there is an equator equidistant from the poles, together with meridians passing at right angles through it. from one pole to another. If there is a spiral figure on the surface, as well as in the interior circles, then there are circles of latitude formed by the spirals in the surface ; and if these are bisected at right angles, the ecliptic will pass through the sections. Thus do poles determine meridians and an equator ; the spirals determine circles of latitude and an ecliptic; thus also begins the same order in the microcosm which we see in the macrocosm, and thus almost the same takes place in the smallest figure as in the largest, or in that of the world ; for even in the larger, before the figures are developed, they are more inflected and curved. All these relations originate solely from the spiral motion. That in these things consist the power and quality of producing a world, such as we contemplate and such as our senses perceive, or, in other words, of advancing the process of its formation to that end in which its phenomena can be placed before us geometrically, or in a manner conformable to its mechanism, will appear in the sequel.

2'. From the regular arrangement of the parts into a spiral figure, arises a general effort of all, tending to one and the same general motion. This effort, if there is nothing extraneous to prevent it, causes a general axillary motion or rotation of the finite round its polar axis. All effort arises from motion. The parts continually tend and put forth an effort towards the same arrangement into which they are reduced by motion; because they tend toward motion so long as there remains in every particle a power and cause of motion. Motion, therefore, adapts the figure to the arrangement, and in that arrangement presents an image of itself. The form of the arrangement determines the effort, together with everything in the effort similar to what is in

the motion. In a word, the parts in their own arrangement move by effort toward and tend to the same motion, to which by their own motion they had come. There is an effort and striving toward the same motion, so long as there remains in any particle any internal force. If the points or particles are in respect to figure, motion, and force, perfectly similar to one another, they must come into a similar relative arrangement, and exercise a perfectly similar effort. Among things absolutely similar there is only one mode, and it is from a mechanical necessity that they flow together, by that mode, into their own arrangement and into no other. Hence arise the force and tendency toward that motion which is inherent in effort. From the regularity of the parts exercising a similar effort, the force receives determination and direction. When all the parts, therefore, unitedly associate, and combine their efforts towards any given motion, this trend and effort is general or common to all; in other words, it is an effort towards a general motion of the whole particle; a motion which cannot be any other than round its own axis. If we imagine a certain number of particles joined together, and united to one another, every one of which, from its inherent power, is exercising a similar effort to motion ; and if these particles similarly cohere in a right line and in a series, then the effort of all is into a right line or into a series; and consequently the motion arising is in accordance with the effort or exertion. If the particles were disposed and connected in their order, not into a right line but into a circle, so that every one of them exercised an effort at the same angle in the direction of its tangent, then from this condition there would arise, were there no impediment, a general effort of all toward the form of their arrangement, or the circle which their motion traces. It would be the same, were small points disposed into a spiral figure ; for since they have intrinsically the power of self movement, and since they all possess a perfectly similar force arising from their perfectly regular position, it follows,



that no other effect can exist from this common cause, than one common motion to which they all tend, and to which one impels the other, and consequently, by reason of the connection and contiguity, the whole cohering series also; that is to say, they all tend to a motion round the axis.

23. From the effort to motion as exercised by all, there arises a progressive motion of all the parts and spirals, but which is much slower than the common or axillary motion. In this motion is preserved a similar arrangement of all the particles, as also the same figure. If all the points tend to motion in a perfectly similar manner, and if the connection and arrangement of the parts are such that they may be still further moved, that is to say, that there may be a figure of motion, then they cannot be at rest; but, in consequence of the inherent force and effort remaining in every point, they mutually impel one another to motion. Let the arrangement of all the parts be assumed to be spiral, formed in motion and for motion; and thus presenting such an equilibrium that the motion of one part is the same with the motion of the other and of all the parts ; so that the motion of the centre is that of the surface; the motion of the surface that of all the intermediate circles, and contrariwise ; it then follows that all the parts in common are urged into motion. This motion, however, is slower than the common axillary motion, or that of the whole composite ; because all the parts cannot move except simultaneously in their contiguity and connection. When a point is moved at the surface, then, according to its situation and connection, a point must be moved at the centre, and also one intermediately between the surface and the centre. There is a consent of the parts to the same arrangement, because there is a connection between them. In order, therefore, for the whole to be in motion, the motion must be slower than the general motion round the axis. Indeed this motion can advance only a single step, while the common motion performs a whole revolution. Nor indeed can the whole series and aggregate

of the finite be put in motion, unless, in this motion, one and the same or a similar arrangement of the parts be preserved. For there is only one arrangement adapted to their figure and motion in which they can be moved as a whole; and unless this is preserved, the equilibrium ceases, as also the mode, belonging to all, of conjoint and united self-movement. In a word, the similarity and equality of the figure and effort in all being given, there is a mechanical necessity, not only for their flowing together into and composing such an entity, but also by means of such an arrangement, a necessity of preserving itself in every motion, fluxion, and state, of retaining its equilibrium by the preservation of its arrangements, and of everywhere perpetually sustaining itself when given over solely to its own mechanism. Thus it is that the particles in the arrangement, which is most perfectly suited for motion, are necessarily self-moved, and in similar ways ; so long as there remains in each such a force that one may become the effort, stimulus, and incitement of itself and of the other. It will be seen in the sequel, that this motion, which we have called progressive, follows the ecliptic; or that all the circles of latitude or spirals accompany one another; and proceed, at equal distances and in regular order, around their centre.

24. To avoid dwelling upon mere effects and results, and too long deferring the consideration of causes, it will be necessary to premise what is that thing in act, or that active force, in a point or finite, which, by its inherent power, produces this mutual motion. This subject is of prime importance. We have said that, in internal motion, or intrinsically in a simple or particle, there is a power of putting itself in motion which is inherent and permanent ; and, by means of this, a power of finiting or limiting some new aggregate. Unless this power were present, they never could arrange themselves' after a spiral manner, or after their figure of motion. Without such a power and quality, the points, with all their general axillary and progressive motion, would remain inert; one would not act upon the next

adjacent, but each would be destitute of all determination and direction. As, however, we are now treating of points, I wish to introduce these observations only by way of anticipation<sup>^</sup> for geometry is scarcely capable of entering into the analogy and reason of pure motion, or that which is in the simple. If there is a spiral figure, that figure must have a centre. The centre of a spiral cannot be where the centre of a circle is ; for a spiral is continually removing itself from the centre, and receding from the circle. The centre of a spiral must therefore be at a distance from the centre of the circle. If the motion of the parts is spiral, then the centre of the parts spirally moved or arranged, is not in the centre which is in the middle of the particle, but in one which is at some distance from it. Hence the centre of gravity is not in the middle, but is near the middle of the particle, of the separate part or point. Let us, therefore, suppose the centre of gravity to be at a distance from the centre of the equator or outermost circle, and at the same time also from the centre of the axillary motion ; it will follow, that, by the axillary motion, the centre of gravity also is carried round into the same motion, and the particle becomes the most highly active at the point in which we find its centre of gravity, whence it becomes like an actual or active thing. The axillary motion, being thus a motion in act, imparts to the centre of gravity the power and effort to give a direction to the whole particle in accordance with itself and its figure; that is to say, into a second motion or into a figure of motion like its own.

Conceive a particle rotating round an axis, and that its centre gravitates not in the axis but near it; in this case, by means of the axillary motion, the centre tends in that direction in which it rotates with the axis ; that is to say, it tends into a circle, together also with the axillary motion. But as there is a progressive motion, in which the figure and arrangements of all the parts are preserved, it follows that the centre of gravity also must continually observe the same

motion or figure of motion. For if the figure and arrangement of the parts are preserved, and if nevertheless the motion of the parts is progressive, then, in this arrangement of the parts so preserved, but at the same time in motion, the particle progresses in like manner as the centre of gravity; and consequently directs its circular gyration into conformity to its own arrangement and motion ; that is to say, not only into a circle, but into a certain surface ; since this centre moves only one step, while the axillary or common motion performs an entire revolution. In a word, if the centre of gravity is not in the very centre of the outermost circle, that is to say, in the centre of the particle, but at some distance from it, and if the particle rotates round its axis it follows, that the centre of gravity is perpetually impelling the particle to a motion extraneous to itself and circular. And further, if the motion of this centre is progressive, it follows that it endeavours to bring into the same figure of progressive motion, that is to say, a superficial figure, the whole of the particle which is in motion. To place the subject in a clearer light; imagine the centre of gravity to be in the plane of the ecliptic, and the axillary motion to be that of the equator, then, by reason of the centre of gravity, there will be a tendency of the body to move in the circle or gyre of the ecliptic. If the particle has always an axillary motion, and if at the same time the centre of gravity moves onwards but more slowly, then the second motion will be in the direction pursued by the centre of gravity or directing force of the particle ; hence the centre is not always being carried round in the same circle and gyre, but at every revolution advances another step, and this continually, at perfectly regular intervals; till, by progressive steps, it has completed the whole circle, which it does in order to form a concentric surface. The case is the same in our larger system. If the ecliptic continually cuts the equator at equal degrees and times ; and if the nodes thus continually progress until they have gone through the whole circle, it

follows that not one but perpetual and innumerable circles are described and represented ; and, by means of these circles, as many surfaces also. If the ecliptic is very distant from the equator, a larger and higher surface is represented ; if the ecliptic is not very distant, a smaller and lower figure of surface is presented. These observations, however, are only cursory, and made with the view of showing the reason why the finite, the particle, or point, tends to a local motion, and consequently possesses an internal inherent power of moving and urging both itself and neighbouring points; and thus by a continual and perfectly similar actiou, of disposing itself, together with these, into the arrangement best fitted for its own motion and figure.

Therefore not only all the primitive force in the point, but that also which is produced in its sequents, consists in this ; that the motion, state, or effort in a point, tends to a spiral figure. This motion, state, and effort, cause an axillary, and, at the same time, a progressive motion. These together produce another or local motion ; a motion in which consists the active power of Uniting and compounding the sequents, and of modifying them through a long series, in the manner in which we perceive, by our senses, the world at large to be modified. We propose, however, to treat each of these propositions more in detail.

25. The motion of all the points must be most perfectly similar and regular; so also must be the progressive motion thence arising, and also the second motion. With regard to the figure both of this and of the progressive motion, it must be most perfectly regular. For the moving points being perfectly similar, it follows that the internal motion and state, in which alone they consist, cannot be otherwise than perfectly similar. Consequently, everything employed in producing the effect is most perfectly similar. There cannot be a spiral arrangement of the points without regularity ; it is only by the most perfect regularity and sequence that the figure is maintained. If any inequality entered into this

motion, it would immediately tend to stop it and disturb the connection and series of the fluent points. The slightest inequality or irregularity in one would cause a similar inequality and irregularity in another ; and so on successively in all, in consequence of the connection between them; hence also in the whole finite. This motion, therefore, consists in regularity itself; so that one point always follows on over the same path of motion as another ; therefore the motion of one is the motion of the other, and the motion of a volume or of all collectively is the same as the motion of one ; or the motion of one is the same as that of a volume. If, therefore, while in this regular arrangement, there arises a motion of the parts or of the whole, the line and figure of progression will also be most perfectly regular, and thus the periods and degrees will be equal, whence a perfectly uniform figure will be produced. Parts which are perfectly similar and simple have only one way in which they can be moved ; for all have a like potency, a like force and effort, a like figure, and, consequently, a like mechanism and geometry; hence, by a mechanical and geometrical necessity, nothing can exist but what has a perfect simplicity and oneness. In all there is only one and the same mode of their self-motion together with the neighbouring ones ; hence there can result only what has a oneness and similarity of modification. If the same and similar causes conspire to one end, then the thing caused or the effect is also similar, as much so as if it were the effect of only one cause; by a plurality, however, of similar causes, the force employed in producing the effect is rendered the stronger. Thus, from the similarity of all the causes employed in producing the finite, there arises in the finite a perfectly similar arrangement, state, and effort of all; there is a perfect similarity of figure, and of consent to general motion ; consequently, of general axillary motion, and of the motion resulting from these two, or local motion.

26. These principles, however, cannot be proved by experiment until we have arrived at elementaries. The principles

which are formed a *priori* by rational philosophy and a certain degree of geometrical connection, receive confirmation also from visible nature ; were there no confirmation from experience, we should here be only building castles in the air. Still, however, at this stage, we cannot appeal to the testimony of experience ; because we are as yet only at the first outset of our principles, where nothing can present itself to the senses in the way of phenomena; for the entities themselves are thus far such that in them compounds and elementaries may begin. Hence they cannot as yet constitute any element, and thus afford us ocular and perceptible experience, since this is first afforded only in the volume of elementary particles, and in an element reduced to some regular arrangement, in which the phenomena may first be mechanically represented. This, however, we are not to look for until we come to the second element; till then, we must travel in the road of philosophy and geometry. Our line of argument, however, will be legitimate, if, with geometry as our guide, we arrive at the station where elementary nature is rendered visible and sensible by experiments and phenomena ; and if the connection of our positions so accords with reason and geometry that from the same experiments and phenomena their various intermediates receive confirmation. In this case the intermediates leading to the element are themselves also experimentally verified. For if the ultimate end be experimentally attested and confirmed, and if the intermediates which lead thither from the first end be geometrically true, and depend connectedly one upon another ; then by the same experience the intermediates also are attested and confirmed. Similarly, if any intermediate be experimentally and geometrically true, the whole chain of connection extending from the primary end becomes verified experimentally, and thus is consistent with both geometry and nature. But up to the present we have no phenomenon derived from these finites and presenting itself immediately to the senses, unless in a very remote way, as for instance the following. We see that the whole motion of the free and

elementary parts tends to a certain spiral gyration ; that all mechanical power is inherent in this motion, and owing to it. We see the solar vortex itself tending to flow into a similar gyre, and forming by a fluxion of this kind larger and smaller circles, also ecliptics, equators, meridians, and all the other circles belonging to the earth and the heavens; imitating on a large scale the modes of the smaller and simple ; or else, the simpler and smaller imitating the motion of the compounded and larger. That there is a certain arrangement of parts agreeing with these circles is manifest in the universe at large, and from innumerable evidences presented by the bodies which move among these particles or in any volume of these particles. In a word, the whole visible world appears to be full of proofs that the general arrangement of its parts is in accordance with certain circles of the world ; the consequence of which is, that the parts which cause this general arrangement are themselves similar. Of this subject, however, we shall treat in our observations on the first and second element.

27. The kind of connection which this finite maintains with the point is evident from this ; that the finite derives its origin from the point, and that it flows from the motion of the points among one another ; that the motion in these finites is similar to the motion in the point; that in this finite there is the same power of producing sequents as there is in the point of producing this finite ; that there is thus a connection between them, arising from the circumstance of one existing from the other, or the finite existing from the point; thus that there is a connection of causes in producing the compound. Without a connection, similarity, and derivation of causes from one into the other, not a single natural thing is produced capable of maintaining, through intermediates, a continuous relation to its first origin. Unless there were a connection between the existence of one cause, and that of another leading from one substantial to another, there could be no end, nor any means leading to that end.. The end



would be where the connection ceased ; and there would be no intermediate. In the view we have taken of the subject, we see not only the origin of the finite from points, but also its connection with them both in regard to existence and causes; we see the finite derive its origin from a cause latent in the point; and that, by means of a similarity of motion, the same cause is translated, as it were, into a finite of such a kind as is able in like manner to produce its own similitude. Here then is the connection between the point and this finite.

## CHAPTER IV.

A PHILOSOPHICAL ENQUIRY CONCERNING THE SECOND FINITE, AND THE MANNER IN WHICH IT SEEMS TO HAVE ORIGINATED SUCCESSIVELY FROM THE SIMPLE FINITE. ALSO, GENERAL OBSERVATIONS ON ITS COEXISTENT, WHICH MAY BE CALLED THE ACTIVE OF THE FIRST FINITE ; AND ON THE MANNER IN WHICH IT IS GEOMETRICALLY DERIVED FROM THE FIRST AND SIMPLE FINITE.

Our world as yet is lying only in embryo. Nothing which can be called elementary has hitherto received birth; no active as yet exists, which, when joined with any finite or passive, produces the essence of any element. The world, which as yet lies in embryo, consists solely of the least possible finites. No point now appears existing by itself, for every one is in this least finite, into the substance of which it has entered; so that as far as regards existence by itself, the point has entirely vanished.

2. Since, therefore, the finite is universally only of one kind ; and since each one is most perfectly similar to another, as being the first finite or smallest substantial; it follows that as yet this is the only thing that can procreate anything, from itself. Until now we find nothing in the whole nature of things capable of modification, except this first substantial, and afterwards the finites or entities proceeding from it. Imagine, therefore, a universe of this kind filled with these smallest finites, and in every one of them a power and quality similar to those in the point, and produced in the finite from the point; it follows that by the same law of

connection, a certain similar finite derives its existence from the fore-mentioned smallest finites, but one comprehended within more numerous and larger terminations and limits; there arises, in fact, what may be called another finite. This other finite cannot arise from itself, but from one more simple. But besides this finite, there is nothing but the first and least substantial, from which, as being more simple and the only thing existing by itself, this second finite derives its origin.

3. Nor can it derive its origin from the more simple and only existing finite except by means of motion, which is the only thing that binds together the particles, which reduces them within fixed bounds, and keeps them there. Without motion, as we have frequently observed, nothing can be finited and limited. It is motion which gives both figure and space; which distinguishes one aggregate of least finites from another; which fixes a distance between the centre and the ultimate boundary, or between one end and another. It is motion, therefore, which is the means and cause of the first finite existing in the second and more compounded.

4. Nor can any motion be conceived between the finite substantials, unless also its cause be at the same time conceived. Now the cause cannot be conceived to exist extraneous to the substantials, since these are the only things which as yet exist. The cause, therefore, must be in the substantial itself, and inhere in it as something essential which produces the thing caused. If, therefore, in the first substantial we have an arrangement of parts or points in a continuous spiral series, and if there is an effort to an axillary and local motion, we are immediately supplied with a cause and power by means of which these first substantials are enabled by their motion to flow together into some new finite.

5. But the cause cannot be efficient, or give rise to an effect, unless there is some contingent means by which it may go forth. The contingent means is this, that the series and

abundance of these smallest substantiate is so great, that they are in contact with one another, and that in consequence all are in a state of reciprocal pressure. Unless this were to happen, the new finite could not be conceived to have come into existence. If there were no such possibility as this, that the abundance of substantiate was so great that one pressed upon another, or that they became a volume or large aggregate, then by the operation of this cause, there could not exist any finite similar to its prior or parent; but, in the place of this finite, there would be an active, of which we shall speak in the following chapter.

If, therefore, there is a least substantial, and if in this substantial the cause of producing a new finite is latent, then we can conceive only two possibilities; one being this, that so great is the abundance of smallest substantiate, that one by contact presses upon the other—a result from which a new finite exists; the other, that the abundance of smallest substantiate is not so great that one by contact presses upon another—a result from which exists the active of the first finite. Let us however come to the definition of our finite.

6. It is another finite entity existing from the motion of simple finites among themselves. It is, therefore, the second substantial of all finite things. That it is the second substantial arising from the motion of the finites, is evident from this; that the universe consists as yet only of first and least substantiate, and consequently cannot derive its origin from any other source. Likewise, since there is a connection of all the finites with the first entity, this second finite existed successively from that which proceeded from the first simple entity, that is to say, from the first substantial.

That this finite came into being mediately by motion, is evident from this ; that there is nothing but motion which can give existence, and which can finite boundaries or fix them to certain limits. It is motion only which can give figure and space; without motion nothing could flow together

into a bounded aggregate. The cause of anything being bounded is motion alone. It is motion, therefore, which distinguishes, bounds, gives figure, makes one thing equal to another, retains it within its limits, and so holds it together that it can subsist as one finite entity capable of being separated from another.

7. From the foregoing remarks it follows that this finite consists of simple finites only, because it is from these alone that it originates.

8. It is not divisible into anything smaller than the simple finites of which it consists. By division we here mean such as is geometric. Hence, in this division, we cannot proceed farther than the first substantial, from which it exists. Geometrically, it is not divisible into points; because points are mere simples, and consequently beyond the sphere of geometry.

9. It is another geometrical entity which is limited, but within very small boundaries; and there is no finite which is smaller, except the first substantial of which it consists. This follows from the theory of its origin and existence.

10. It is endowed with a figure similar to that of the first substantial. For it arises from the first substantial, just as the latter arises from the point. It originates by a similar mode and motion, and consequently by a similar figure of motion. Since then its origin is similar, as also the motion by which it arises, it follows that the figure arising from it is similar. From similarity in origin, figure, motion, and cause, nothing exists but what is similar; the difference being only that of dimension.

11. Its figure approaches as nearly as possible to the most perfect figure of the finites; but it is not the most perfect. The figures of all these finites are similar; but, nevertheless, there may be a certain unlikeness among them. We have said that the figure of the simple or point is the most perfect, and consequently the most perfectly

similar ; the next to which, in perfection, was the figure of the first finite ; because it had proceeded from a simple and most perfect entity. With this first substantial, however, first begins mode. This it is which first begins to be susceptible of modification ; for modification pertains to that which is substantial ; and everything substantial is susceptible of modification. Everything which is dissimilar, and recedes from perfection, arises from modes. The more numerous, therefore, are the modes, and the longer the series of their succession, the greater is the dissimilarity, and the more imperfectly does the thing exist. If the series of modifications be manifold, so great may become the dissimilarity between entities compounded by the modifications of antecedents, that not one will appear similar to another; not one will be perfect either as to figure or any other essential. It is, therefore, by modes, that whatever renders anything imperfect and dissimilar exists. Now since the first substantial is the first entity capable of modification, nothing can be conceived in it as geometrically imperfect and dissimilar. In, however, its subsequent or second finite, something dissimilar and imperfect begins to be capable of existing ; because this finite arises by the modification of the prior, and from the prior. Still the dissimilarity and imperfection cannot be so great as in the entities which succeed. No entities, therefore, which are many times compounded, can be fully and absolutely like one another.

12. The internal motion, arrangement, and state of this finite are similar to the internal motion, arrangement, and state of the first substantial. For from a similar cause, power of motion, quality, and figure, by which the substantial originated from points, does this finite also originate from the first substantials. Consequently the effect, the thing caused and bearing the impression, must be similar; a conclusion which is geometrically evident.

13. The motion of the whole, or the common axillary

motion, also the motion of the parts or the progressive motion, as also the second motion, if it has freedom, is similar to the common, progressive, and resulting motion of the first finite. From a like cause proceeds a like effect. In the individual parts of this finite, or in the first finites, there is nothing dissimilar, unequal, or angular ; the figure of all is similar, as likewise the figure of the arrangement of the points. In all there is a like space, a like motion thence resulting, whether axillary, progressive, or local; as also a like force and effort tending to these motions. Both kinds of entities or finites, therefore, are geometrically and mechanically similar. There is nothing angular either in their figure or in their motion ; whatever is within them is circular, because it is spiral; whenever any inequality arises, it does so in consequence of inequality of figure, or difference of angles. Hence it may be geometrically concluded, that nothing dissimilar can be produced from what is purely circular and spiral. In the very production itself there is a mechanical necessity that what is produced shall be like that which produces it. There is derived, therefore, into this finite, from the primitive power, a similarity to itself, both in regard to figure and motion, whether axillary, progressive, or local. For the same reasons also, it follows that the situation and progression of the centre of gravity in the second finite, is similar to the situation and progression of the centre of gravity in the first.

14. The velocity of the second finite, in regard to its general, progressive, and local motion, is less than the velocity of the first finite. The modification of active force •consists in velocity. It is by velocity that the state of the active force is determined ; so that velocity is thus, as it were, the limit of the motive force. In order to move a larger mass from its place, a greater active force is required than to move a smaller. There must always be a proportion between the active force and the mass. If there is the same active force and a larger mass, the velocity becomes less than it

would be if the mass were smaller. In the present case, the active force remains the same, both because the figure is similar and one and the same, and because the number of parts is the same. The mass, however, increases according to the degree of compounding; consequently the relation between the active force and mass becomes greater and more disproportioned ; consequently, also, the modification of the active force, which consists in velocity, becomes less ; that is to say, there is a diminished velocity in the mass and larger compounded body than in the smaller; for which reason the velocity of this finite, both as to axillary, progressive, and local motion, becomes less than the velocity in the first finite.

15. The first velocity ratio is in the motion of the first finite; the second ratio is in the motion of this second finite ; and this finite is, in regard to substance, the second boundary. In the first finite there is a ratio between its progressive and axillary motion; the progressive is slower than the axillary; and hence we are supplied with the first velocity ratio. In the second finite, also, there is a ratio between the progressive and axillary motion ; hence we are supplied with a second velocity ratio. And since the first proportion is similar to the second, we establish this analogy ; that as the progressive motion of the first finite is to that of the second, so is the axillary motion of the first to that of the second. In regard to substance, however, this second finite is a second boundary, because, in the first substantial is the first boundary, and in the pure simple there is none.

16. In itself, and in its own internal state and motion, it possesses the same force and quality as the first substantial ; so that it is able to set bounds to and produce succeeding and more compounded finites; that is to say, it has received from the first substantial all its power of setting bounds to the sequent. Nevertheless, this power by which it is enabled to set bounds is no longer that of the first sub-



stantial, but becomes its own proper acquired power. That in this second finite there is the same quality of setting bounds to and compounding sequents as there was in the first, follows from the similarity of internal motion, progressive motion, and figure. Similar motions in each supply us with a similar result. This power, however, is no longer that of the first substantial; because this had already exhausted all its own in producing the finite, and preserving it in a state similar to its own. Hence its force has now passed into its progeny, which, by reason of its similitude, possesses in potency the same as the first substantial had in compounding it.

17. In relation to things much bounded and compounded, the second finite is small, and as yet scarcely comprehensible geometrically. Since it is next to the least substantial, it must necessarily be small; and particularly in relation to things much finited. That it is as yet scarcely comprehensible geometrically, appears from this, that in regard to substance, it is only the second boundary. Geometry requires at least three boundaries before it can determine anything by analysis. There must, therefore, be a third before geometry can acknowledge this finite as its own.

18. It cannot be concluded from principles of geometry, but only from those of reason, that the motion in a point is spiral. However, in the motion and arrangement of the sequents, both the geometrician and physicist may see that it is spiral. Geometry only defines figure, describes it by lines, investigates its angles and other properties, and gives demonstrations by analysis and rules proper to itself; but it is quite unable to demonstrate that there must be a figure of this kind in the point and first substantial. That there is such a figure, both in the point and in the first substantial, must be concluded from arguments *a priori* and *a posteriori*; next must come mechanics with its powers; and finally geometry completes the train. If, therefore, it be taken for granted that this figure of motion exists in the first substantial, then

a similar figure of motion in its subsequent products follows by geometrical and mechanical necessity.

That reason may infer *a priori* that there is such a figure in the point, in the first substantial and the succeeding Unites of the same quality, appears from this ; that reason is unable to admit any other cause or any other means of existence or of being, than motion ; since without motion, and without change of state by means of motion, nothing further could possibly exist; it therefore acknowledges motion as the first thing which produces and sustains anything. The same reason, likewise, acknowledges that by such a motion there is an occupation of space; that this space has its limits extending from one extremity to the other, from one point of a limit to another; that the space, therefore, has form ; because reason cannot represent motion without space, nor space without form, for these are attributes of motion. Nor can reason admit of the existence of motion, unless at the same time it admits of a given direction, or some path along which it tends; that is to say, some figure of motion before the space is formed, or some path which the motion, as it proceeds, describes and figures out. Nor does reason stop here, but advances still further ; inferring, for instance, that among the finites there must be some primary thing which is least, and that there must be some simple antecedent to the least finite. Here reason stops, because into the Infinite it cannot penetrate. It therefore acknowledges that the origin of things is in the simple ; that in the simple there is a certain motion, together with all the attributes of that motion, just as in things not simple, but only so by analogy.

Admitting, therefore, as reason does, the existence of motion in the simple, and the origin of things to be from the simple, it also recognises in the simple the existence of something most perfect, equal, and similar ; for it as yet discerns no mode, except the one which has to arise from the first and least substantial, and its successives ; it consequently sees nothing that is mutable, unequal and dissimilar, except in those things

with which modes exist. Without modification it can know of no change of state, or variation, in the limits of any entity. Whatever, therefore, it admits as being jn\_ the simple, it admits as being most perfect ; and if this is most perfect, so also must be the figure formed by its motion.

Beason, therefore, perceives that there must be something in the motion and figure of the simple, which is absolutely perfect; if there be something absolutely perfect, then, from a series of conclusions drawn from *a priori* principles, it will also admit that its figure is absolutely perfect; and the only figure which has this degree of perfection is the circular; and if the figure of motion is conceived as being in space, then no other can be conceived than the absolutely perfect spiral. Nor does the chain of reasoning stop here, but proceeds still further ; so that, by adding one link to another, we can make the chain reach to geometry. Thus if the figure of motion is spiral, and if the motion which runs out into this figure encloses space, reason immediately concludes that the figure of the motion is such that its ultimate boundary is a circle ; because a circle is the ultimate circumference to which the motion by a spiral course arrives, and because it cannot, by any spiral course, go beyond this circumference. And if so, then all its spiral motions must end in the circular, or that which bounds its surface, or is the ultimate of its motion, and in which are the limits both of its motion and of its figure. Granting this, that is to say, granting the existence of a centre, a circumference, and a spiral figure of motion from the centre to the circumference, we are enabled to infer what the figure of spiral motion is. For reason perceives from *a priori* principles, that the spirals which are nearest the centre must be the most highly spiral, and that those nearest the circumference must be the least spiral; that is, they are almost circular.

The same is the case with the figures of motion between the centre and circumference. The spirals near the centre are

the most highly spiral, and the more the motion approaches the ultimate circumference, the less spiral do they become ; till, in the last circumference itself, they become the least spiral. Thus we may arrive *a priori* at the figure of motion. Geometry, which does not venture beyond its lines and analyses, is itself unable to conclude that the figure must be of the kind we have mentioned ; but only shows by its lines and calculus what the boundaries of such a figure are.

Reason, whether *a priori* or *a posteriori*, or both together, can see that one finite proceeds successively from another ; and that if any new finite is created, there must be a motion of the finites among one another ; it concludes, that in the preceding finite there is a certain force, by which it may be put in motion, in order that the succeeding finite may exist; that in motion is the cause and the very force itself, or that which causes the existence of the sequents by a motion among one another. Reason concludes therefore *a priori*, *a posteriori*, and from both together, that the figure of the motion must be such as possesses within it such a force and quality as to enable it to be the cause of the sequent, or the cause of some motion by which the sequent may be created. Such then is the extent to which we may proceed by argument *a priori*, or by rational and natural philosophy.

Here, for the first time, mechanics and its powers come to our help. Without the help of mechanics we cannot conclude anything with certainty. We must confirm our *a priori* observations by mechanics, and thus *a posteriori*. The science of mechanics then confirms the fact, that in the spiral motion [of a substantial] resides all its power of freely flowing from one extremity to another, and that it cannot arrive more easily at any end by any other motion ; so that, if anything is to be conceived as continuously in motion, that continuity must be conceived of as spiral. In the lever, mechanics sees its potency and forces ; in the inclined plane, its motion; in

the perpetual lever, a perpetual potency ; in the perpetually-inclined plane, perpetual motion ; in the spiral figure, which represents both, it sees concentrated all its capabilities.

From mechanics we learn that a body in motion moves according to the centre of its motion, or its centre of gravity ; and tends in the direction in which its centre tends ; all the parts of the body conspiring with the centre. If the centre of gravity consists in motion, so that the centre is itself formed by a continuous and perfectly regular motion ; in this case, we learn from mechanics, that such a body, already in motion, has a tendency to a still further motion, which is under the direction of the centre of gravity. Reason itself sees that there is nothing else to direct such a body but its centre, with which all the parts of its internal state conspire ; or in which, as it were, all the parts, periods or degrees of motion are concentrated. Such a point will be the directing one of the whole body, because no other point in the body can do this; the direction must, therefore, be according to the centre of the whole. If, therefore, this centre of gravity be not the centre of a quiescent body, but the centre of some motion, it immediately becomes lively and active, or a living force, which in a quiescent body is dead and inert. Mechanics likewise confirms the fact that a body put in motion moves according to its centre ; and that a body, consisting entirely of motion, not only moves according to its centre, but that by this motion its force becomes living and actual, inasmuch as it has a tendency to move with the whole of its body consisting of motion. But of this we shall speak in the subsequent chapter.

We must now finally come to the principles of geometry with its lines and calculus. For geometry shows not only that such lines as we have mentioned may be assigned; but that, when assigned, the diameters, angles and circles they form, have their relation and analysis.

19. We proceed then to the geometry of this spiral. The

reader must pardon me, if I here detain his attention by lines and geometry, while perhaps he may be wishing to hasten on to the important subjects which await us in the sequel.

Fig. 1.

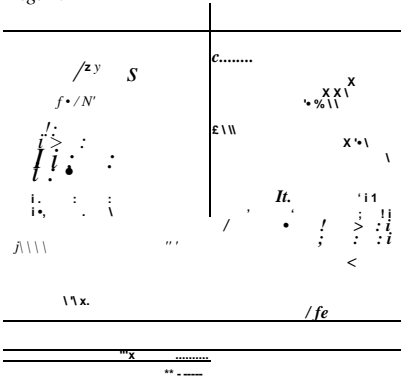

In figure 1 we have the spiral figure formed by motion, wheie the motion begins in the centre a, and by continued spires passes through 6,  $li > i$ ,  $k$ , to  $d$ ,  $e$ ,  $f$ ,  $g$ , or the ultimate circumference, which is circular, and in which the motion terminates; so that the whole boundary of the spiral is equi-distant from its centre.

Now since this figure is described by motion, this motion must be either greatest in the centre and least in the circumference, or least in the centre and greatest in the circumference. There is no third state unless it be one of quiescence. By either of these motions a spiral is formed, which is bounded by a circular periphery. Let us first enquire, on geometrical principles, into the spiral figure which is formed, when the motion is greatest in the centre and least in this circumference; and from this derive our inference with respect to the other case. That the geometry of the spiral may be better understood, let us conceive of it as some large or immense volume, flowing by spiral motion into such a vortex; for geometrical figures are more easily presented to our thought by large than by small boundaries.

If the motion is greatest in the centre, and least in the circumference, then it must gradually diminish as it passes from the centre to the circumference. The diminution of this motion cannot be otherwise than according to a simple proportion; because it arises only from the resistance of the moving points. And since there is a consecutive series of these

points from the centre to the circumference, the motion is retarded by this series at every successive step ; and inasmuch as the cause of retardation and resistance is simple, the variation of velocity is simple ; so that the greatest velocity is in the centre, it is less in the circumferences, and least in the ultimate periphery. Hence at each step of the progression the velocity in the several circumferences becomes less and less; it is less in  $e$  than in  $a$  (fig. 1.); less in  $h$  than in  $b$ ; less in  $i$  than in  $h$ ; least in  $d$  and  $e$ ; and none in  $f$  and  $g$ . This variation is the simple one of the ratio of the distances from one point of the arc to another, and so on. Since every successive resistance arises from the series of points flowing into the same figure, and the resistance can be considered only according to the figure into which the series of points flows; it follows, that according to the figure itself, the variation of velocity is simple; but not so, if considered in reference to the diameter from  $a$  through  $b$ ,  $c$ , to  $d$ .

Since the motion is spiral, and is every moment more and more directly receding from its centre by the radius or diameter, another variation presents itself, which must be taken into consideration, both as it is in the spiral series and at every successive distance from the centre. Since we have thus another variation, we have in this case, according to the common rule, a duplicate ratio from the centre to the circumference, or a ratio in accordance with the diameter from  $abc$  to  $d$ . Thus, when a body falls through any medium, if at each moment there be added uniformly to its natural simple arithmetical ratio a certain further degree of velocity, the velocity becomes duplicate ; or it is the ratio of the simple ratios when squared.

In this manner we may compare the spiral with the parabola, whose ordinates and diameters are in a duplicate ratio, or in the ratio of a given number or line to that number or line multiplied into itself, or of its square to its cube.<sup>1</sup>

<sup>1</sup> The reader will note an unusual definition of a duplicate ratio. A duplicate ratio is the ratio of the squares of the quantities.—Tr s.

When the ratio, therefore, is given, spirals may be transposed into another curve. Thus—

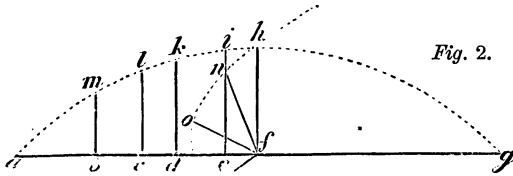

Fig. 2.

the spiral diameter  $f q$  may be transferred to  $b$ , as  $b m$ ;  $f o$  to  $c$ , as  $c l$ ;  $f n$  to  $d$ , as  $d k$ . Or we may take any arc of a spiral (for the most simple ratio is in the arc), and regarding it as an axis, may erect upon it all the ordinates of the spiral.

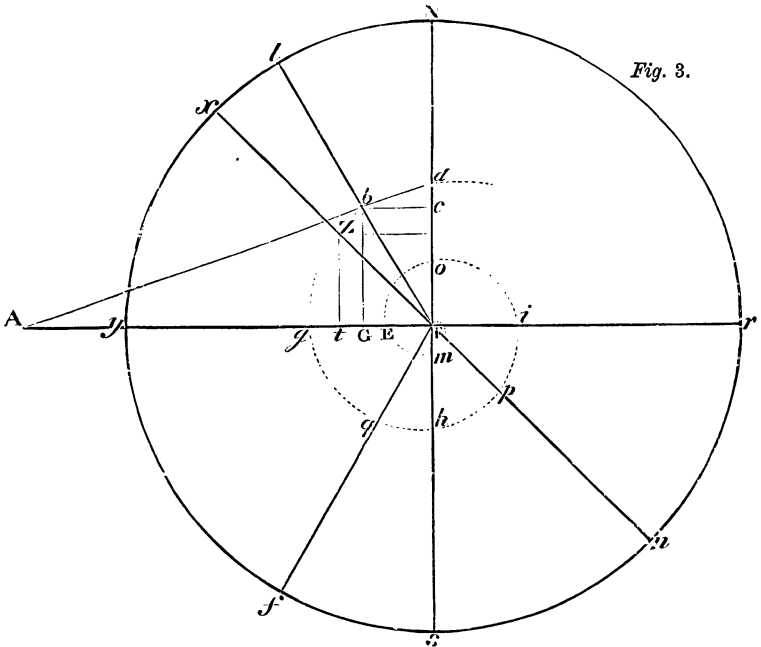

Fig. 3.

The ratio of the spiral figure being given, its lines may then be determined by an analytical computation of differences or minimals (see fig. 3). Since the figure is spiral, it follows that all the circles continually recede from their ultimate circumference and approach nearer and nearer to the centre ; and that no two points can be given which are equi-distant from



this centre ; no two diameters equal to each other; for  $Nd$  is more distant from the centre than  $yg$ ;  $yg$  than  $sh$  ;  $sh$  than  $ri$ ;  $ri$  than  $No$ , and so on. Now the ratio of these being duplicate, [the squares of successive digits] their differences are in arithmetical progression, as 3, 5, 7, 9, 11. The differences of these, however, or the differences of the differences, are always equal; just as in the foregoing numbers, 5 - 3, 7 - 5, 9 - 7, 11 - 9 = 2.<sup>1</sup> Let the length measured along the diameter from the circumference of the spiral toward the centre =  $l$ ; a difference =  $a$  ; the difference of the differences =  $b$  ; then if  $a = 3$ ,  $b$  will = 2 ; and  $a + b = 5$  ;  $a + 2b = 7$  ;  $a + 3b = 9$  ;  $a + 4b = 11$ , and so on. Let now the length  $Nd = l$ , and it follows, that  $yg$  may =  $l + a$  ;  $sh = l + a + b$  ;  $ri = l + a + 2b$  ;  $No = l + a + 3b$  ;  $ye = l + a + 4b$  ;  $sm = l + a + 5b$ , &c. The intermediate parts are obtained from the ratio of the angles ; for if  $Nd$ , be to  $No$  in duplicate ratio, then we have the

<sup>1</sup> The original diagram is not well drawn; there are also some printer's errors in the text which we have set right. There are also difficulties in the argument. For in fig. 1 a spiral is described in which the radii of successive spires measured along a semidiameter vary in a duplicate ratio. But in fig. 3 we have the spiral of Archimedes, which has not this property. The following is suggested as an alternative reading referring to fig 1, but as to lettering to fig. 3.

Let the altitude as measured on the diameter from the circumference of the limiting circle to some initial point on the spiral =  $l$ : the first differences of the altitudes corresponding to equal angular units, quadrants for example =  $ay$ ,  $a_2$ ,  $ct_3$ , etc., in which  $a_1 = a + b$  ;  $a_2 = a + 2b$  ; etc.,  $b$  being the constant second difference, or the difference of the differences. Then if  $a = 3$ , and the second differences for one quadrant =  $b = 2$ ,  $a + b = 5$  ;  $a + 2b = 7$  ; and so on. Let now the initial altitude =  $l$ , and it follows that the altitudes corresponding to successive quadrants are  $l + a$ ;  $l + a + (a + b)$ ;  $l + a + (a + b) + (a + 2b)$ ; etc. Suppose we wish to interpolate the altitude for 30° beyond the third quadrant from  $l$ . Since the increment of the altitude for the fourth quadrant is  $a + 3b$ , one-third of this quantity must be added to the previous altitude, giving

$$l + a + (a + b) + (a + 2b) + \frac{1}{3}(a + 3b) = l + 4b;$$

and similarly for any other intermediate angle. In the spiral of Archimedes, fig. 3, where the first differences are constant and equal to  $b$  for one quadrant, if  $Nd = l$ , since the succeeding altitudes are in arithmetical progression,  $yg = l + b$ ;  $sh = l + 2b$ ;  $ri = l + 3b$ ;  $No = l + 4b$ ; and the difference between the radii of successive spires, measured on a common diameter, is in every case =  $4b$ . If we draw the tangent to the curve at  $d = dA$ , and from a point  $\&$ , near enough to  $d$  to permit practical coincidence between arc and tangent through  $bd$ , drop a perpendicular  $be$  upon the radius  $Fd$ , we then have  $FA : Fd :: be : cd$ . But in the limit when the angle  $bFd$  becomes infinitesimal,  $be = rdf$ , and  $cd = dr$ , whence, the radius being  $Fd$ , we have the differential equation for the subtangent  $FA = r^2$  and by the differential calculus we may also obtain the tangent  $dA$ , the rectified curvature  $dg$ , the area  $dFgZd$ , and any other value we please. See also the translators' preface.

difference  $do$ ; and because the differences of the differences are equal, they will be in the ratio of the angles ; hence when  $Nd$  is given, so is  $sh$ ; so also in the same circle is given  $Nd-sh$ ; as also the halves of  $do$ ; and consequently  $xZ$ , which is midway between  $d$  and  $g$ , will =  $I + 1 + Jb$  ; and  $fg$  which is  $j$  of the distance from  $g$  to  $A$ , or  $f$  of the quadrant, will =  $I + a + j I$ ; and  $pn$ , which is midway between  $i$  and  $h$ , will =  $I + a + 1|&$ . Now let the angle  $bFd$  be assumed as  $yV$  = of a circle, or 30 degrees; or let it be  $J$  of the quadrant of a circle ; then  $lb = I + 1 + J6$  ; in short, by the differences of the differences we obtain  $dF$ ,  $bF$ ,  $ZF$ , and all the diameters in the same quadrant. We obtain, therefore, by these means  $bF$ , the angle  $bFd$ , and the right angle at  $c$  ; we also obtain  $be$  or  $CrF$ ; likewise  $cF$  or  $bG$ ; consequently the proportion  $bG : dF :: AG : AF$ , or the equation of the spiral curve in its quadrant. The same method we pursue in obtaining other values. When, therefore, in any quadrant, the equation of the spiral circle is given, we may then, in the usual way, form the differential triangle  $deb$ , and consequently by proper formulae and the differential calculus, we may obtain the subtangent  $FA$ , the tangent  $dA$ , the rectified curvature  $dg$ , the area  $dFgZd$ , and any other value we please.

That the reader may better understand the subject, we will add another explanation.

If the ratio is duplicate, the differences of all the semidiameters are in a certain arithmetical proportion, and the differences of these differences are always equal.<sup>1</sup> If in our computation, the semidiameter  $Fd$  be assumed =  $d - a - b$ , and  $Fo = d - a - mb$ , then all the semidiameters from  $d$  to  $b$ ,  $Z$ ,  $g$ ,  $q$ ,  $h$ ,  $p$ ,  $i$ ,  $o$ , as far as the centre, differ in arithmetical proportion and according to the ratio of the angles.<sup>2</sup> If  $Fd = d - a - b$ , and  $Fo = d - a - mb$ , and the angle subtended by  $db = \wedge$  of a circle, then the semidiameter  $Fb = d - a - \text{TM}^*$ .

<sup>1</sup> This is not so in fig. 3. The differences of the differences would be equal if the diameters were the squares of successive digits.—**Tbs.**

<sup>2</sup> We suggest as an alternative : If the semidiameter  $Fd$  be assumed =  $d - a$ , where  $d$  is the semidiameter of the limiting circle, and  $a$  is the altitude or distance from that circle to the spiral at the point  $d$ .—**Tbs.**

The radius  $Fg$ , where the quadrant is,  $= d - a - \text{TM}b$ ,  $Fh = d - a - \text{TM}b$ , because it is the half of the circle, and so on to  $Fo = d - a - mb$ . In this manner we may obtain any semidiameter ; as we here do  $Fd$  and  $Fb$  at a given angle ; and the angle  $bFd$ , the right angle at  $c$ , and the semidiameter  $Fb$  being given, we obtain  $be$  and  $GF$ , consequently the ratio of the ordinates  $bG$ ,  $Zt$ . &c. ; also the ratio of the abscissae  $gG$ , or  $gE$ , or  $gF$ , or the equation of the spiral curve in any quadrant. This being found, we obtain the differential triangle  $bed$ ; and consequently, by further calculation and formulas, the tangent  $dA$ , the subtangent  $AF$ , the curvature  $dZg$ , the area  $dbZgF$ , as also the centre of motion or gravity. If  $m$ , or the difference of the differences  $= 4^l$  or  $5^\wedge$ , that is to say, if  $d - a - 4b = d - a - \wedge b$  ; and if any angle be given (as one of  $30^\circ$ ); then for  $360^\circ$  substitute this angle, so that instead of  $d - a -$  we shall have  $d - a - \text{TM}b$ . If the angle be  $75^\circ$ , then it will be  $d - a - \wedge b$ , and so on.

We now come to certain laws of motion. Let such a vortex as we have spoken of be conceived upon a large scale ; or let us imagine a spiral motion running over a considerable distance from the centre to the circumference, or in the opposite direction. Let this motion be least in the circumference and greatest at the centre. In this vortex, let a certain very heavy body be conceived as falling; in which case we affirm, that a body, heavier than the vortical element or its volume, will be carried from the centre to the circumference ; but, if lighter, it will be carried from the circumference to the centre. For the heavier body follows the stream of motion, and tends with this motion to circumferences more and more remote, till it reaches the last. If the weight of the body be such that it cannot be whirled by the stream of particles in a vortex, then it will tend from the centre, along the diameter, to the circumference. The contrary will be the case, if the falling body be lighter than the volume of moving particles in this vortex.

<sup>1</sup> See note 1, p. 122.

With regard to the velocity of the very heavy body in falling from the centre to the circumference, this velocity will diminish in the duplicate ratio of the distances from the centre. For the motion of the falling body, represented by the diameter of the vortex, from the centre to the circumference, will be similar to the motion of the parts in the vortex ; which, in the direction of the diameter from the circumference to the centre, is in a duplicate ratio. If, however, the motion be greatest in the circumference and least in the centre, then the velocity will increase; and for the same reason as before, in the duplicate ratio of the distance from the centre to the circumference.

If in the kind of vortex in which the motion is greatest in the centre and least in the circumference a heavy body tends from the centre to the circumference, and in its path does not move along the diameter, but is deflected by the vortex into innumerable spiral circles before it arrives at its ultimate circumference, then we affirm that the velocity of this body is diminished almost in a simple ratio ; but, in a diameter or line described by a perpendicular fall, its velocity is diminished in a duplicate ratio. For if the body is carried sideways into circles, it is carried into almost the same stream and motion as the flowing parts ; which move in a simple ratio along the spiral, but in a duplicate ratio through the diameter. If, however, the motion is least in the centre and greatest in the circumference, and the body, as before, is carried sideways into gyrations, then its velocity is almost in a simple ratio from the centre to the circumferences, that is to say, in its passage through the spiral circles, but not so in a perpendicular path along the diameter.

If a body moves not in a right line along the diameter to the circumference, but through circles, it follows that its weight is not so great but that it may be carried along in the vortical current. If a heavy body descends from the centre of a vortex of this kind to a certain given circumference within the vortex and there stops, it follows that in

this circumference there is an equilibrium of its weight, and of the volume of those parts of the vortex which are in this circumference, or at this distance from the centre.

If a body stops in any given circumference, or at any given distance from the centre, it follows that it is carried into a circle, and revolves around its centre always at an equal distance from it. For since it stops at a certain distance, it is in a state of equilibrium with the volume of the parts at this distance; consequently it is carried by their motion into a circle; but in whatever part of the circle it is, there is the same equilibrium. Hence, as it keeps an equal distance from the centre, it moves in a circle.

If the body revolves round a centre at a constant distance from it, and hence in a circle, it follows that the motion of this body in this circle is always uniform. For, at the same distance from the centre, the velocity is the same; this velocity being, as we have said, increased or diminished in a duplicate ratio to the distances from the centre.

If in any volume of the parts of a vortex, at the same distance from the centre, a body is directed by some forces so as to move to ulterior circumferences, it follows that, in pursuing this direction, the body moves along some other path than the common one of the vortex, and that a curve is described, partaking both of a duplicate and of a simple ratio. The motion in this curve is not unlike the motion of a projectile in the vortex, and partakes of [elements of] velocity both uniform [circular], and accelerated in a duplicate ratio [radial].

If a body in this vortex, tending from its centre to some circumference, becomes, from certain unknown causes, lighter and lighter, it follows that its motion is nevertheless in such a ratio that its differences are in arithmetical progression ; and that the differences of these are equal; as in the case of a body falling along the diameter from the centre to any circumference. For if at each moment the body did not

become lighter and lighter, the velocity of the body running outwards would be in a duplicate ratio. But if at every moment there were an accession or recession of anything which increased or diminished the velocity of this motion, observing a duplicate ratio, still the differences of its differences would be equal. This, however, would be the case, only if the body issued out along the diameter in a right line from the centre.

With regard to the velocity of a body at any distance from the centre of a vortex in which the motion is greatest in the centre and least in the circumferences, I observe, that it is in a [sub]duplicate ratio of the distances [from the ultimate circumference] along the diameter. Let the distance from the highest circumference measured along the diameter toward the centre =  $I$ ; the velocity —  $c$ . Then according to the common rule,  $L :: c^2 : C^2$ ; that is to say, the velocities are in the subduplicate ratio of the lengths or distances from the ultimate circumference. Or thus, if the whole distance from the ultimate periphery to the centre =  $z$ ; and  $z - l = r$  one radius, and  $Z - L = R$  the other radius; we shall then have this relation;  $z - r : Z - R :: c^2 : C^2$ ; or the velocities are in the subduplicate ratio of the differences of the radii. If the motion is least in the centre and greatest in the circumference, then the velocity is in the [sub]duplicate ratio of the radii.

In the same manner the times [in the first case] are [inversely] in the subduplicate ratio of the distances from the ultimate circumference to the centre; for, according to the general rule, the times are [inversely] as the velocities. Again, in the contrary case, or that in which the motion is least near the centre and greatest near the circumference, the times are in like manner in the subduplicate ratio of the radii.

If the medium or the volume of particles through which the body falls is different in two different vortices, the same body will require a longer time for its fall in one medium than in the other; although it will continue to observe a duplicate ratio to the distance in its perpendicular descent; and also in

THE SECOND FINITE.

each medium the same ratio of velocities and times, with a difference only in degrees and periods. Hence if, with any velocity which the body ultimately acquired in its fall from the ultimate circumference to some other which is nearer the centre, it moves uniformly through a circle or in a right line, then, according to the well-known rule, it will perform double the space or double the distance in the same time.

If in a vortex in which the motion is greatest at the centre and least in the extreme circumference, there move two bodies at unequal distances from the centre, but so that each in its place is always at the same distance from the centre, or moves in a circle ; then the squares of the periodic times of each body will be as the squares of the radii divided by their complements extending to the ultimate circumference. In fig. 1 (p. 118), let  $dc = l$  or the length from the ultimate circumference ;  $ca = r$  or the radius of the same circle;  $db = L$  ;  $ba = R$ ;  $da = z$ , or the whole radius. In this case, the squares of the periodical times of the circle  $c$ , to the squares of the periodic times of the circle  $b$  will be thus :

$$t^2 : T^2 :: \frac{r^2}{z} \text{ or what is the same, } t^2 : T^2 :: Lr^2 : IR^2.$$

The reason is, that the velocities at  $c$  and  $b$  in the figure are computed according to the general rule  $I \setminus L \setminus c^2 \setminus C \setminus$  (observe  $t$  denotes the time and  $c$  the velocity), or  $Lc^2 = IC^2$ ; therefore  $c = \frac{I}{L} C$  the velocity in the circle  $c$ ; and  $C = -$ . — the

velocity in the circle  $b$ . If the circumferences of the respective circles be divided by the velocities, we then obtain the periodic time. Instead of the circumferences, let the radii be taken, because they have the same ratio to one another as their circles ; in this case  $ac = r$ , and if divided by  $\frac{C * JI}{-----}$ , becomes

which is the periodic time of the circle  $e$  ; while the

periodic time of the circle  $b = \frac{R - JI}{c \cdot Li}$ . Instead of  $c$ , or the

velocity in one circle, let us put its equivalent  $>JI$ , and instead

of  $C$ ,  $\sqrt{L}$ ; in which case the periodic times are  $\frac{rR}{\sqrt{I}}$  and  $Jj$ .

Squaring these, the result is  $\frac{rR}{IL}$  and  $—$ ; therefore  $t^2 : T^2 :: \frac{rR}{IL} : —$ ,

according to the proposition. If the motion is least in the centre and greatest in the circumference, then the squares of the periodic times are as the cubes of the distances from the centre, or  $t^2 : T^2 :: r^3 : R^3$ .<sup>1</sup> In the contrary case, however, of

which we have spoken above,  $t^2 : T^2 :: \frac{r^2 R^2}{L L} : —$ . But in or near

the [semi-radius] of the vortex,  $L$  does not much differ from  $r$ , or  $L = r$ ; and in like manner  $I = R$ . In this case or in the [semi-

radius] of the vortex, if instead of  $L$  we put  $r$ , and instead of  $I$  we put  $R$ , we have the forementioned proportion  $t^2 : T^2 :: r^3 : R^3$ .

Nor does the computation in each case much differ, if the bodies are on each side almost equally distant, each from the

[semi-radius] of its own vortex; in which case  $I$  will not so much differ from  $R$ , and  $L$  from  $r$ , but that it may be almost

substituted for it.

Let two circles be given in a vortex whose motion is greatest in the centre and least in the circumference, the

ratio of the velocity in the two circles is required. By computation the velocities in those circles are as the products of

the radii and of the times. For if  $t^2 : T^2 :: \frac{r^2 I^2}{L L}$  and instead

of  $I$  we put  $c^2$  or the velocity, its equivalent will then be  $t^2 : T^2 :: \frac{r^2 E^2}{c^2 Q^2}$ .

Whence it follows, that  $c : OwTr : tR$ . In the other vortex, however, in which the velocity is greatest in

the circumference and least in the centre, the velocities are in the subduplicate ratio of the radii, that is to say,

$r : 7\mathcal{E} :: [c^2 : G^2]$ . If, however, in each case the body is in the middle of the vortex, both computations coincide;<sup>1</sup> so also will

<sup>1</sup> This is not so. The first proportion should be  $t^2 : T^2 :: r : R$ .—Tbs.



they if the two circles be at equal distances from the centre ; for then  $b = R$  and  $L - r$  nearly.

In a vortex whose motion is greatest in the centre and least in the circumference, the centripetal forces are as the altitudes divided by the radii. Let  $v$  = centripetal force ;

then is  $v : V :: \frac{IL}{rR}$  — or  $v : V :: IR : Lr$ . The reason is. that the velocity near the circle  $c$ , or at the first altitude  $I$ , is  $I : Li : c^2 : C^2$ , according to the rule ; or  $Lc^2 = IC^2$  and  $c^2 = \frac{IQ^2}{L}$ . Now

the velocity is a mean proportional between the radius and the centripetal force. The radius =  $r$ ; hence  $r : \frac{C^2}{JL} ::$

$\frac{JIC^2}{JL} = v$ , or  $v = \frac{C^2}{Lr}$  = centripetal force.. Since  $C^2$  is equal or

similar to  $L$ , omit — and we have  $v = \frac{C^2}{Lr}$ . In the same

manner at the other radius or  $Z$ ,  $\frac{L}{R} = F$  : therefore  $v : V :: \frac{IL}{rR}$

But in the vortex in which the motion is greatest in the circumference and least in the centre, the centripetal forces are reciprocally as the squares of the radii <sup>1</sup> that is to say  $v : \sim F' : R^2 v r^2$ . In the former case, as we have shewn,  $v : V :: IR : Lr$ . In the middle of the vortex, however, or in two circles equidistant from the middle, there is not much difference between  $I$  and  $R$  and between  $L$  and  $r$ .

20. Finally, that the links of our argument may be duly connected, it will be sufficient to show the connection of the second finite with the one preceding; since I have already shown the connection of the preceding one with the point. For if there is a connection of the second finite with the first and of the first with the simple, it follows that there is a connection between all the three, and of the last with the first. That there is a connection between the second finite and first substantial, appears from its origin ; for it is from

<sup>1</sup> This does not agree with previous statements.—Tr s.

the first substantial alone that the second finite originated. It appears, also, from the manner of its origin ; because it derived its existence from the first substantial, in the same manner as the latter derived its existence from the point. Consequently, there is a connection between the three in regard to mode. But to speak specifically in regard to motion and arrangement; since the internal motion and state of this finite is the same as the motion and state of its antecedents, and the motion and state of the antecedent is the same as the motion and state of those which preceded it, or of the points, there appears to be, in regard to motion and arrangement, a similarity between this finite and its antecedent, as also between this, antecedent and its preceding simple ; so that the motions of the first and third bear a ratio and analogy to one another. For instance ; as the motion of the first is to the motion of the second, so is the motion of the second to that of the third; and so on in a continued geometrical relation : or as the axillary motion of the former is to its progressive motion, so is the axillary motion of the latter to its progressive motion. And if the progressive motion of the former were the same with the axillary motion of the latter, there would be a continued geometrical ratio between them ; but this is not always the case. There is, also, in regard to the power and quality of producing subsequent finites, a connection between the second and the first. In a word, there is, in regard to every one of its parts and modes, a connection between the second finite and the first, consequently between the second finite and the point, through the medium of the first substantial.

**GENERAL OBSERVATIONS ON THE COEXISTENT OF THIS FINITE,  
WHICH WE CALL THE ACTIVE OF THE FIRST FINITE.**

In the present chapter I ought to refer to the existence of another entity; because it arises from the first substantial

or least finite equally with the second finite which has been discussed. And because it draws its origin from the first finite, I here present observations upon it; for this entity. is\_ the coexistent of the first finite.

At the commencement of this chapter it was seen that as yet, in our nascent world, there was no other substantial than the one which we have called the primary; and that the second finite derived its existence from the first finites only by means of motion. Before, however, its existence was possible, I have supposed that one substantial was near to another and that they were in mutual contact; whence there was a mechanical necessity that the finite entity should coalesce into another similar to its first parent. In case, however, it should not happen that one pressed upon the other by mutual contact, I now observe, that nevertheless a new entity, not so similar to the finite, would arise from this substantial. Since, therefore, only these two suppositions can be made, namely, either that the finites closely touch each other and are in mutual contact, or that they do not; and since I have stated that the finite came into existence only in the former case, it remains now for me to say what that is which proceeds from the first substantial, supposing the substantials were not in mutual contact, but dissociated and separated. I observe then, that, in this case, there would naturally exist a certain new entity dissimilar to the forementioned finite; and since no third supposition can be made, we proceed to inquire what is this kind of entity which could come into the world with its other coexistent and coeval entity.

We have then to demonstrate from the connection between the existences of things, that the same cause must operate in the production of this entity, which operates in the production of the second finite; each proceeds from the same substantial; therefore also from the same cause. If one be a parent in which no diversity can as yet be considered, then, by means of the same force and mechanism which it possesses within

itself, it must generate both the one and the other. Unless there were the same cause and the same substantial to produce, there must result some different entity; which is contrary to the tenor of our argument. The first thing, therefore, which we must presume in the connection between the existences of things, is that there is only one cause in one and the same subject, which gives rise to each production ; since there is nothing else which can as yet be predicated of the substantial. It will appear in the sequel, that the same axillary motion in the substantial produced this active by the same force and actual power by which it created the second finite of which we have treated.

If there is a connection between the things, it also follows that what was produced from the same substantial and by the same cause is similar in all the essentials of motion and figure ; or, that the active, in regard to its motion, figure, and numerous essentials, is similar to its coexisting finite or finite proceeding from the same origin. For if its origin and cause are the same, it follows that it is itself similar.

Now there is nothing which can produce anything dissimilar between the second finite and this coexistent active, except that of which we have spoken, namely, that the second finite took its origin in some volume of substantials which were in contact with one another; but that the active existed from no such volume, of which the parts were in contact with one another. There is only one mode which generates the difference. This mode can produce only the following result; that the coexisting finite shall consist of a certain volume of substantials confluent by their motion into some new finite, but that this new finite shall run not in the volume, but outside the volume, without any consociates, into the same figure of motion. Since, therefore, the cases are only two, as we have said, so also there is only one mode which can vary the effect, or occasion the finite to exist with several consociates or without them.

The origin of this entity is, therefore, outside the volume

of several; as is consequently this entity itself, which spontaneously runs into a certain gyre, and by its motion describes a certain surface, which consists only in the motion of one substantial; whence it deserves to be called an active, and indeed the active of the first substantial.

Unless there were two entities in the nascent world, one active and another passive, no elementary could be produced; as will be shown in the sequel. In the present case, we have one entity capable of moving, and another entity capable of being moved. One is an entity which acts ; the other an entity suffering itself to be acted upon ; from which two contraries may be compounded a third, which will be an elementary compound, and, together with its associates, will be capable of applying itself to every motion. Of this, however, we shall speak in the sequel.

## CHAPTER V.

**OBSERVATIONS SPECIFICALLY ON THE ACTIVE OF THE FIRST FINITE; ITS ORIGIN FROM THE FIRST SIMPLE FINITE; ITS MOTION, FIGURE, STATE, AND OTHER ATTRIBUTES AND MODIFICATIONS, SHOWING THAT THIS ACTIVE IS ONE, AND CONSTITUTES THE SUN OF OUR SYSTEM ; THAT IT ALSO FORMS THE FIRST ELEMENTARY PARTICLES.**

1. The active of the first substantial is only the motion of one substantial running into circles by means of which a surface is formed. If it happens that the first sub-

\* substantial are not in mutual contact, then, in obedience to their effort and inherent force, they run out into local motion; there is nothing to prevent their running out with all their force and setting themselves fully in motion. The active, therefore, of the first substantial is nothing but the first finite passing into a local motion. This is the reason why we call it an active, and why indeed it is so, as it has a local motion ; for active force consists solely of local motion.

2. The axillary, progressive, and local motion in a simple or point cannot be investigated in any other way than as an unknown quantity in algebraic analysis, namely, by means of what is known ; and, consequently, by means of what is posterior and geometrical; and from the axillary, progressive, and local motion, as given in the sequents, it may be concluded that there was a something similar in their first origin; and the quality of the motions in the points may be elucidated by a similar analysis and mode of computation. Because in the simple there is nothing substantial that is moved, but nevertheless a something which

must be understood as being similar to motion and figure, we must assume it as an unknown quantity, in order that we may introduce it, together with known quantities, into our algebraical or geometrical calculations. The geometrical data; therefore, being taken as known, by an arithmetical and analytical computation, we may arrive at that which is not geometrical, or which is unknown. In no other way can we arrive at a knowledge of the axillary, progressive, and local motion in a point. Assuming, therefore, that there are these motions in a point, it follows that every point possesses an active force; and that the aggregate of these points disposes itself by motion into an arrangement conformable to the similar motion and figure of each ; and that it thus exhibits the first substantial, or its active, according to our -description in the third chapter.

3. If in the first substantial the points dispose themselves into a spiral arrangement, it follows, by mechanical necessity, that this substantial must have an axillary rotation. JFor these points could not be disposed into such an arrangement, unless they all conspired and consented to the same arrangement and figure, and were all so situated as to be •constantly able to preserve their figure. Since, therefore, all are so arranged so that they all have the same spiral motion, they hence, by their common effort, and force, mutually urge themselves into one common motion. This motion will be accordant with their arrangement, and consequently can be no other than the common motion of all the points, or of the entire substantial, round the poles or their axis. By spiral flexures round one pole, these points tend from the centre to the surface, in the same manner as they tend by spiral flexures round the other pole, from the surface to the centre. There is, therefore, between the poles, an intermediate motion into which the points tend by reason of their arrangement and effort; namely, a motion according to the equator, or round the axis or centre of the equator.

4. If, in the first substantial, the points dispose them-

selves into a spiral arrangement, it follows, by mechanical necessity, that this substantial is progressively moved in accordance with the arrangement or order of the spires; that is to say, there is in it a motion of the parts or a progressive motion. For all the points are in the arrangement and figure of their motion, and linked into spirals by a perpetual connection and series. Since there is constantly in every point a something actual, one point must necessarily act and press upon the neighbouring one; consequently upon the whole series, upon all that are connected with it, or contiguous to it. And since there is nothing in their figure to prevent their being moved, there consequently results—a progressive motion ; and this can be no other than such as is accordant with the preservation of a similar figure and arrangement of the parts. The motion, therefore, will be in regular sequence, or accordant with the circles or arrangement of all the spires, or with the general arrangement.

5. The centre of gravity is not in the middle of the substantial, but near its middle; and it follows the progressive motion of the parts and of the figure. As its arrangement or figure is spiral, its centre cannot be in the middle. It would be in the middle if its arrangement or figure were simply circular; if, therefore, we grant that its arrangement or figure is spiral, we must also grant that the centre of this figure is at a distance from its middle. Because they are points or particles which compose its arrangement or figure, it follows that the centre is its centre of gravity. Since the centre of gravity is not in the middle, but on one side and since the points or particles are in progressive motion since, also, in this progressive motion, the same figure of arrangement is always preserved ; it follows that the centre of gravity likewise progresses, and that this progressive motion of the centre of gravity is the same as that of the whole figure, or of all the parts.

The centre of gravity is in the plane of the ecliptic, not



in the plane of the equator; and its progressive motion is according to regular sequence, or according to the ecliptic of its figure. Since the centre of gravity exists by reason of the spiral figure and arrangement, it must invariably keep the path of that figure ; and since this path is the same as that of the progressive motion, and is thus in the plane of the ecliptic, by which all the spires are bisected between the poles, the centre of gravity is in the plane of the ecliptic, and not in the plane of the equator. Hence the centre of gravity moves on with the current of the parts, according to regular sequence, or according to the ecliptic.

6. By reason of its axillary motion, there is an effort in the whole compound to produce in itself a second or local motion; and consequently this second or local motion is in accordance with the motion of the centre of gravity. If the centre of gravity is not in the middle of the compound but on one side, the compound gravitates to this side ; and, where it is heaviest, there is a continual tendency to fly off in the direction of the tangent. The case is the same as if you were to make a circle heavier in one part than in another, and then set it rotating round an axis ; while rotating on its axis the circle will tend toward the part which is the heavier; and therefore, if the circle were in freedom, it would fly off in the direction of the tangent to the heavier part. Now because the centre of gravity follows the general or axillary motion of the whole compound, and cannot pursue a straight path in the direction of the tangent, but, on account of its rotation, moves in accordance with this tangent and its continual movement round in a circle (that is to say, the same revolving motion as the centre of gravity), it consequently describes a circle consonant with its motion and velocity.

Since the centre of gravity has not only an axillary rotation, together with the compound, but likewise progresses in its plane or in accordance with the ecliptic; the local motion describes not only a circle, but also a surface. Since the

progressive motion is slower than the general, and advances only one step while the general motion accomplishes a whole circle; and since the centre of gravity progresses in a similar manner, and in the plane of the ecliptic, it follows, that at every rotation it makes some advance, and in its rotation moves itself sideways every moment; and thus constantly makes some other and new section and node of its gyre with the equator. It consequently moves its folds spirally; and these taken collectively form the surface.

7. All the actives of this kind flow with one and the same velocity, neither less nor greater; they always describe similar gyres and circles; nor can they form any either less or greater. Inasmuch as the active runs out according to the determination, direction, or motion of its centre of gravity, and according to the tangent of its motion : it consequently cannot do so with any velocity greater or less than accords with the force given by the axillary rotation. If the axillary rotation be swifter, then its power of flying off becomes greater, and consequently it makes a swifter excursion ; if the axillary rotation be slower, its excursive motion is slower. The force itself is more active according to the magnitude of the velocity. If, therefore, the axillary rotation of the compound gives activity to the force; it follows that, since the velocity of the axillary motion is the same; since the distance of the centre of gravity from the middle is the same ; since the figure of the compound is always the same; the active we describe cannot flow into circles larger or smaller than such as are proper to it, nor with any other velocity than such as is similar to that of the generative and directing force. If the velocity is greater, the circles formed are smaller ; for by a greater velocity the rotation is completed the more quickly. The contrary is the case, if the velocity is less. If the velocity is the same, and the distance from the centre of gravity to the middle is the same, then perfectly similar gyrations will be performed.

8. In this active there is nothing substantial, with the

exception of that one which alone is in a state of motion ; yet a surface may be represented by motion, just as if it consisted of substantials only. A representation by motion of what is continuous is very common. For if a particle, moving in any given direction, describes a line or a circle, a line or a circle becomes immediately represented by this motion ; and the continuity, coherence, and contiguity appear the greater in proportion as the motion is swifter, or as it is more repeatedly present at any given point. Thus, figure 4, if the little ball D be v

round by the radius

Fig. 4.

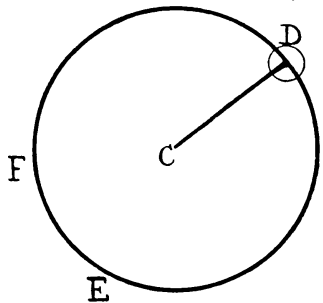

proceeding from the centre C, as by a sling, a circle will be represented by such a rotation; although in the circle there would be nothing substantial but the ball itself. The point where the ball is present, is perpetually substantial and material. If the velocity is so great that its progressive positions and periods are imperceptible, it follows that in every point of the circle the ball is, as it were, present and perceptible. A resemblance to a substance may therefore be produced by motion.

9. From these observations it follows that in the surface of the active, there is no point which can be truly called substantial, except the one where the substantial in motion is itself present.

10. Nevertheless this entity is most perfectly active, and also endowed with a considerable power of acting upon the nearest finites. The power of acting accompanies local motion. In local motion itself resides all motive and active force ; and without this motion it is impossible to conceive the existence of any *vis viva*. Now, since an entity of this kind consists only of motion, so that the whole of its form is nothing but motion, it follows that the whole of this formed entity is most perfectly active. Acting force is greater or less according to the magnitude of velocity. With

a smaller velocity, which is, as it were, a smaller measure of local motion, the force is less ; in a greater velocity, the force is greater. If, therefore, in a moving body the velocity is the greatest possible, then its energy of acting will be the greatest possible. If the entity which is acted upon and which thus acts, possesses any weight, then its energy is augmented in proportion to its weight; although the degree of velocity is enabled to supply what is deficient in mass. If the body moved be so acted upon as to be itself enabled to act in every direction, at every point and at every angle, it possesses a more multiplied and larger energy than a body in motion which is able to act only on one part and at one or at few angles. Let us assume some real surface consisting of finite entities only, let this surface be assumed as perpetually moving, then it will similarly be possessed of an active force ; but one which is determined only at one angle, namely, the angle of its contact with the entity upon which it runs; it acts only at one part, or similarly in every place, and it may, therefore, be said to act with a simple force. The active, however, of which we before were speaking, has no determinate force of acting ; but is enabled to act, at all angles, upon each finite it meets; it can act, for instance, at a right angle, an oblique, obtuse, acute angle, or perpendicularly; thus at all angles and at all parts of the body. There is no point in the body opposed to it upon which it cannot act at all angles; nor, in any body that meets it, is there any angle upon which it may not act in a similar manner, either with its whole force, or with the half of it, whether that force be greater or less. In a word, it is enabled to come to, to overtake, or to come into collision with any other body. There is nothing in any kind of action, which it does not possess. For it is the only thing in motion, and nothing is present which can detract anything from its determination ; everywhere it traces its own periphery; and its action upon another particle is according to the position of its periphery, and the position of the particle upon which it acts. And since it is cap-

able of being in every position, so in every position it acts according to its angle, upwards, sideways, and downwards. In a word, there is nothing in any activity which cannot be present in this. The surface, therefore, which is thus formed by the motion of one, is a real active entity of motion.

11. Nowhere in this surface can there be conceived a point, which is not acting, although at different times. For though the entire surface consists only of one point or substantial, yet by motion it is always, as it were, present in every imaginary point of its surface; and hence every point of this surface is acting, but only at different times, for it cannot be in every point of the superficies at one and the same instant. In proportion as its periods are shorter, or its velocity greater, it is more or less active.

12. In respect to this active, finites linked in a series, or in an aggregate, are passive. For a finite linked with others in a series, or in an aggregate, possesses none but an axillary and progressive motion; no local motion, which yet is the only active one, except in a series. For without local motion no activity can be even conceived. The finite, therefore, is passive in relation to the active, which has none but local motion. Every finite is also an active, in so far as it has an axillary motion and consists of particles which are in a perpetually progressive motion, and thus it has a force of acting. However, from this force of acting—because the finite, when in a series or aggregate of others is, as it were, under restriction—nothing proceeds but the ability, inclination, and effort to actuate itself in some different way, or to pass into a local motion ; moreover this force is directed and determined to the neighbouring finites, in order that a new finite may be produced. Therefore, it is passive in so far as it is restrained and has not become active.

13. This surface may, according to the different degrees of velocity, be represented as more and more like a continuous

and finite surface. If the velocity is the greatest possible, the moving substantial in the surface is present at any point within the least possible time; and is hence more frequently present in any point of the surface than if the velocity were less; consequently the figure or surface, so represented by its presence, differs from a continuous surface or figure only in regard to its periodic presence. The shorter the periodic times, the more perfect is the simulation of a continuity, and contrariwise.

14. This surface has no real dimension, but it may be called an apparent, imaginary, and pure surface. It has no length, because it consists only of one substantial ; nor breadth, except in the place where the substantial is; in the infinite number of places in which the substantial is not present, it is destitute of breadth; it has, therefore, no dimension except at one point, and this one point does not of itself constitute a surface. The surface, therefore, is void of all breadth. Much less has it a third dimension or depth ; for of this it is manifestly void ; except when, by its eccentricity [oscillation of the plane of rotation ?], it is translated from one place to another, so that, by means of these translations, the surface may apparently occupy space. On this subject, however, we shall speak more at large in our observations on the fifth active. Neither has the surface any real centre, for since the surface is not real nor always in the same place, neither is the centre ; unless it is so considered relatively to the surface which it describes by its motion.

15. When present, it acts perpetually upon every finite ; by its presence it is enabled to act upon the finites and to dispose them to a certain motion, arrangement, and figure. In the sequel it will be evident that it cannot act upon actives flowing close by it; or that it is rarely in contact with them, so as to be able to exercise upon them any action. Upon every finite, however, which is present, it acts, and by its motion disposes it into a situation. For since it is able to act in all directions, as well directly as obliquely, or to one

side or the other, or upwards and downwards, it follows that whatever comes in its way it drives, impels, and urges in a different direction; for since it is perpetually acting and soliciting, it will at length urge the body to some place where it can no longer thus be acted upon, and where it may remain free from its impulse and action ; that is to say, it will urge it into some arrangement and figure, of which we shall speak in a following chapter. It is, however, to be understood, that a single active cannot impel any finites into any definite arrangement ; this can be done only by a space consisting of several actives.

16. Several actives of this kind may flow within one and the same space, without any collision or conflict. For if several and innumerable actives revolve in the same space, one cannot possibly come into contact with another till after an infinite number of revolutions and periods. Imagine how many points there may be in one surface, while in all these points there is only one substantial, or one point which is substantial, and innumerable others which are destitute of it, before it can present itself in them. If, therefore, there were innumerable points in one space, they could not come into contact with one another, unless two substantials were present in one and the same point ; an event which could not take place among an infinite number of points, except after an infinite number of returns to the same place or point of the surface. No collision can take place such that one can run up against the other which precedes it; because the velocity of all is equal and the circumference described by all is equally distant from any given centre. If the motion be equal, one cannot strike another or overtake another on its path from behind, or more speedily or by a greater velocity come upon another; all, however numerous, will maintain their orderly sequence : thus there will be no impact. Consequently one will not easily meet another and occasion a conflict; because, as we have said; it can be present at one time only at one point of

the surface. There may be an infinite number of places occupied by others; these places may be left vacant, until the point returns, after having passed through a long series of circles. In a word, if all the points have the same velocity and the same circumference ; and if the circumference consists of only one substantial: if all observe the same periods in returning to the same place; it follows that a case of contact can seldom happen, but that all the actives must perform their gyrations without hindrance from the others flowing with them in the same space.

17. Several may simultaneously adapt themselves to any angle and space ; and taken collectively they may represent any figure. For if several, in one space, may perpetually perform their revolutions without impact, opposition or conflict; so at the same time may they apply themselves at every angle, and to every space. If by impact or conflict with finites, they are deflected in another direction or to some distance, at that very distance they immediately describe their own same peripheries, nor do they bring it back again ; for in whatever place they are, they are always in their own circumference, whether it be at a greater or less distance from the finites. They are in no other place than their own circumference ; for they cannot possibly run out into any other than their own, or the one into which they are perpetually carried by their own inherent and natural force. If there are several actives of the same kind in one space, these imaginarily occupy the space by their virtual and apparent circumferences; and in these there is no place or point which they do not touch and, as it were, occupy.

With regard to our other observation, that, when taken collectively, they can represent any figure; it is evident from the following circumstance, that all these circumferences can be present in one space, and this a very small one, and that one periphery may apparently, as it were, cross and cut another; that near one surface there may appear



innumerable others, crossing as it were through that one; as may be seen in figure 5, where we may perceive one surface crossing over the other, according as the centre of each is within or without the surface of the other. For were the surfaces real and consisted only of finite entities, then the nearness of one circumference to the other would be only that of contact ; and in one space there might

Fig. 5.

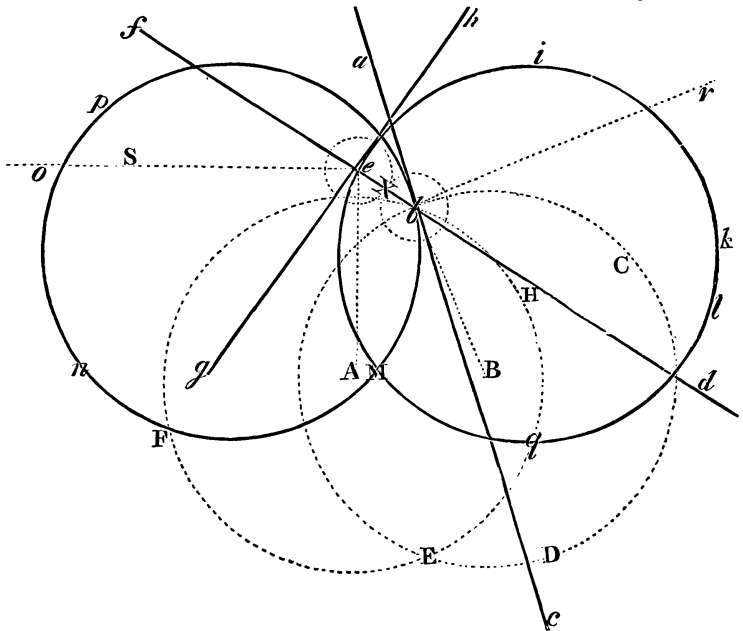

be as many as could find a place in it. With these actives, however, the contrary is the case ; for they do not constitute any real surface, but only one that is apparent and figured out by motion. Surfaces of this kind may be without number, for there is between them no conjunction by contact ; hence the surface of one may be carried through the surface of the other. Innumerable surfaces may, as it were, flow across one. The smallest part of one and also the largest may extend beyond the surface of  
 i<sub>k</sub>

another, and may again withdraw itself within the interior of this other. In a word, there may be represented in one space as many surfaces as may, in the chart of a circle, be described from an infinite number of centres both within and without the circle of the other. For we may place their centre wherever we please. Since therefore these surfaces may be described from innumerable centres, whether these centres be assumed as within, or on, or without the surface of the other, it follows that, when taken collectively, they may not only occupy a small space but may also collectively represent any figure.-

18. Several in one space can rarely be in contact with one another, unless they are present in too great number. For if the number is so great that in their motion one must press against another, then can they first meet together and at once coalesce into one finite. Of this subject, however, we shall speak in our observations on the third finite.

19. If they meet one another, they nevertheless continue the same rotation over a surface. Actives, wherever they are, are in their own periphery. No acting force urges them into any other periphery than their own. If they are diverted from their position by collision with finites or with their moving associates, then they are deflected into some other position ; but still always into one in which they continue to describe their own periphery; because wherever its substantial is, there also is its periphery; hence we cannot say that it has its periphery in any fixed and determinate place. In figure 5, if  $e$  and  $b$  be two substantial actives which meet each other in  $X$ , the motion of each in the direction of the tangent instantly ceases; each also may change its place ; still they continue to gyrate, or to be in the same place; but to gyrate as it were from a different centre ; for the substantial  $b$  may run out from the same place  $b$  into the periphery  $CDE$ , into the circle  $HEF$ , or into the circle  $MFp$ , or into any one of an infinite number of other circles, according

as it receives its direction from any other active or finite meeting it.

20. Innumerable actives may occupy an exceedingly large space. They may occupy a space as large as the solar one, and much larger than it. That the solar space is occupied entirely by these actives and by those of the second finite, will be explained in the sequel.

21. They may also flow within an extremely small space, within a surface consisting of finites. We have stated above, that these apparent surfaces may occupy a small space; that they may exercise their force upon the contiguous finites ; and impel and dispose them into a certain regular arrangement. They may flow, therefore, within a surface consisting of finites.

22. Several collectively in one space possess a greater force of acting than a smaller number. For from several in one space several surfaces exist ; the motive forces and actions are, as it were, more in number; one and the same body may be more frequently acted upon by them; by one directly, by another obliquely ; that is to say, one body may be acted upon by several in a variety of ways, more frequently and, as it were, continually. The more numerous, therefore, are the actives, the greater action and force can they simultaneously exert upon all the bodies they meet, so as to leave not one of them intact.

23. This active arises from the same force and cause from which arose its coeval or coexisting finite. The power of this substantial to pass into gyration, arises, as we have frequently said, from the internal force or motion of the points. It is from the same cause, also, that several points pressing upon each other by mutual contact, give rise to a certain new finite. For one substantial tends to a periphery similar to the periphery of this active ; so do a second, a third, and innumerable contiguous ones ; if, therefore, they all tend at once to the same periphery, if also one is contiguous to the other, then ought all collectively, in consequence of this motion, to

flow together into such an arrangement as I have shown in the case of the second finite. Thus the cause of the second finite is the same as the cause of this active. Therefore both are called coeval and coexistent; since they proceed from the same origin and the same cause, and may come into existence at the same time and at the same moment.

24. The apparent surface of the active is similar to the surface of its coexisting finite. For the cause impelling both the one and the other into motion, is one and the same; and hence there exists a similarity in the surface.

25. The fact of the active running into circles, is favourable to activity only by enabling it to be everywhere present, and to act everywhere; but the fact of its being able to exert force upon the bodies it meets, arises solely from its velocity and mass.

26. It could exist before its finite, and could be the cause of the contingency that second finites arose. In our series of first principles, there is nothing more difficult than the knowledge of the causes from which contingencies have been produced. Indeed, the cause itself lies hidden in the first motion; but, as it is contingent, and as there may be a great variety of contingencies, we must seek for the first cause from the first motion ; and not only the first cause, but also all the others. We cannot penetrate, therefore, into the causes of contingencies, except by means of a knowledge of the successive existence of things ; and if we are without this knowledge, we are unable to discover the nature of the contingency required for a thing to exist in such and in no other manner. In our nascent world it as yet seems possible only for the two contingencies before mentioned to exist; therefore we may arrive at the causes of those more easily than at the causes of subsequent contingencies.

With regard, therefore, to the cause of the contingency, or existence of a second finite, this we may in some measure discover from the existence" of the first substantial. For if there were one only first substantial to occupy the nascent

world, it follows that all the substantials must have been so in contact that there was no space left for them to run out into their apparent peripheries. Yet reason dictates, that, if this was the case in one place, it was the same in another, because the whole of that space was of necessity similarly full. But because, according to our hypothesis, actives had proceeded out of it, it follows that the substantials were no more in contact with one another than would allow of the existence of actives ; if, therefore, they were not in contact, it follows that, in the first place, actives existed, and that after these, finites were necessarily produced. For actives occupy space; they perpetually act upon the adjacent finites, urge, solicit, and impel them from place to place, until the finites have betaken themselves to some quarter where they are free from the influence thus exercised upon them and need not fear further attacks. If, therefore, the first actives have already arisen, and if the space is filled with actives, it follows that the substantials, flowing as yet into no gyre, become more and more confined, so as gradually to be rendered less able to pass out into rotations and become active; this restraint increases, till by contact one presses upon another, and they are thus enabled to congregate together into one finite and new particle.

27. Because the centre of gravity always remains at an equal distance from the middle of the substantial so long as the same velocity of progressive and axillary motion remains among the moving points, or so long as the same figure of motion continues; therefore also the substantial itself, continually running out into spiral circles according to its centre of gravity, can do no otherwise than keep at a certain distance from a given centre, or always describe the same equal periphery and surface.

From figures 6, 7, 8, we may see the figure which the moving substantial must describe, and the circles by which it forms its apparent surface. It can describe only a larger circle, because it proceeds from the margin of one pole to

the margin of another. Thus Fig. 6, at  $gF$  and  $ab$  are poles,  $ab$  and  $gF$  being polar circles. The circles which it

Fig. 6.

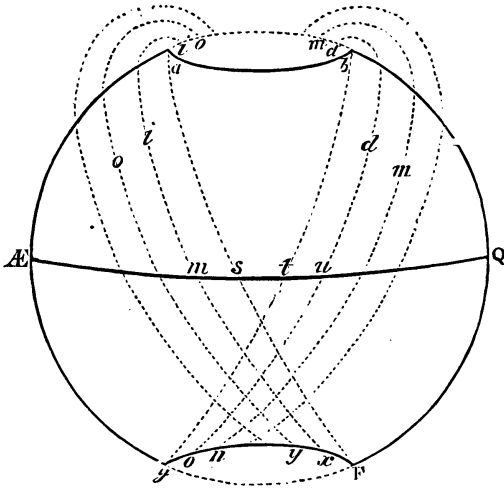

describes are  $gb, od, nm, \&c.$ , from the lower pole to the upper which are marked by dots. From the other side of

Fig. 7.

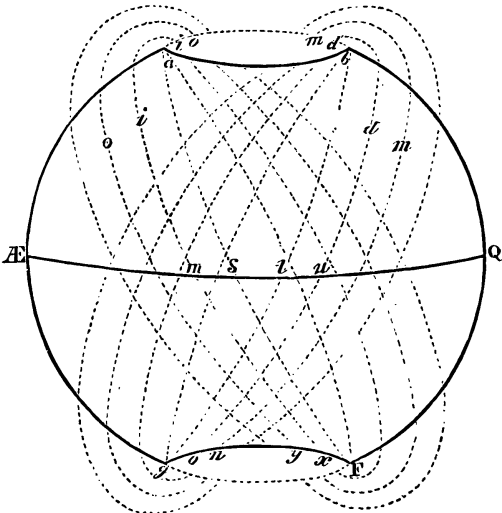

the upper pole it runs back by similar circles to the lower. Fig. 7 represents the same at each pole. The motion of this

active is represented also in figure 8 ; where 2EQR is the equator; the pole, which is made conspicuous, being situated

Fig.

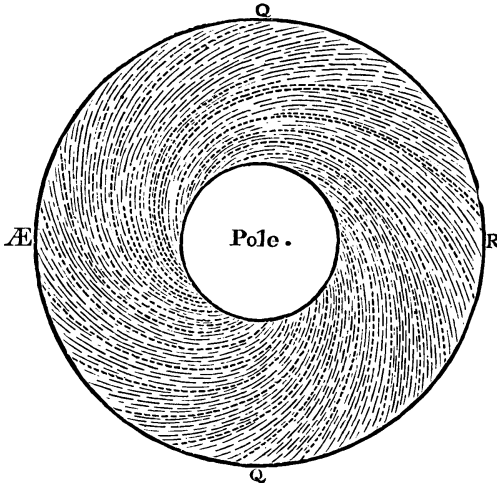

in the middle. Thus are formed larger circles, meridians, and circles of latitude. If these are bisected at right angles, we obtain their ecliptic.

28. With respect to the force acquired on account of the velocity, it is evident, from the mechanical laws of motion, that the quantity of the motion is produced from the mass multiplied into the velocity, and that the momentum is in proportion to the mass and velocity. Therefore a body moving rapidly has a greater power of acting or pressing than a body moving slowly, so that if it is the same body in motion, the force is proportioned to the velocity. But inasmuch as the force arises in like manner from the substances, and a heavier substance with the same velocity has a greater force and momentum than a smaller one, hence a smaller or lighter substance may have the same force as a larger, if the velocity in the smaller be proportionally greater than it is in the larger substance. And although this substantial which is moved be the smallest, nevertheless,

on account of its immense velocity, which is of the first degree, this smallest substantial must likewise possess a force proportioned to its velocity.

29. Let us now come to experience. But here again, destitute of experience, we have formed our principles ; for the senses have no experience of things so minute. These actives are beyond the sphere of the most subtle sense ; for they act upon those more compounded particles, whose motion being conveyed by contact with the particles constituting a still grosser element, form at length a communication with the organs of the senses. We thus see, as it were, from afar, but nevertheless by reason, that there are entities in which resides all possible power of activity. When we arrive at the actives which are more compounded and which constitute our elementary fire, we may then for the first time physically and geometrically demonstrate that it is in this, or a similar action of the actives, that all igneous force consists. Of this subject, however, we shall speak in the sequel.

The fact that a body may by internal motion be made to pass into another motion, is one which ocular experience every day testifies. Every being in the world which possesses animation, whether man or brute, is impelled or actuated by internal motion only. The various members, such as the arms and feet, follow, together with the whole body, the motion of the muscles; the muscles follow the motion of still smaller organs, or it may be still smaller muscles; the organs follow the motion of others, which are most highly subtle, and which are determined into action by the soul through the will. Thus the first motion comes from the most subtle, and proceeds gradually to the more and more compounded ; until the entire machine passes into motion. In this way arise the mechanical imitations of those who have contrived automata or human figures attached to clocks; and which are internally supplied with motive powers and tendons, that not only move their arms and feet but put the whole machinery into a local motion. What is more common



than for a particle to be put, by its internal motion, into a rectilinear or circular motion, in case the centre of motion within be not in the centre of the particle but at a distance from it ? If in the case of a watch, the~“ chain, by which the elastic power of the spring is restrained, is snapped, the whole machine is thrown into a hurried, circular, and local motion. These are things too well known to require further observation.

30. By way of conclusion we must now briefly speak of the connection between this active and the finite. This connection has been indicated throughout the whole of the description of this active. It has been shown, for instance, that this active derives its origin from the first substantial, from its internal motion, and from the power of this motion, by a perfectly regular form of fluxion. And since the second finite, which is the coexistent or coeval of this active, has been shown, in our preceding chapter, to have derived its origin from the same cause, and its connection with the first substantial has been demonstrated, so also from the same demonstration follows the connection of this active with the first substantial; especially as the only difference between the two relates to the contingency of each in regard to its origin.

Although the second finite and the active proceed as twins from one parent, still each is of a contrary character. The one is, as it were, quite opposed to the other. The One is most highly active, the other is most highly passive; so that they cannot mutually consort and associate with each other in the same place. Therefore in the following chapter we shall have to show in what manner they ultimately come into concord; how one consociates itself with the other, so that both can be in the same place and live one common life. Let us however leave this Proteus or Vertumnus of ours, that is to say, the active, which is able to convert itself into all shapes, and proceed to ulterior subjects; first premising, however, a few observations on the active of the point.

WHETHER THERE IS ANY ACTIVE BELONGING TO THE POINT ;  
AND IF SO, WHAT IS ITS NATURE?

We have already spoken of the active of the substantial, or of the one which had proceeded from the first substantial. The question now is whether we may presume that any active proceeded from the point. On this subject we observe, that from the same argument used in showing that an active proceeded from the first substantial, it may also be shown that an active proceeded from the point. In both there is the same kind of motion. In the point there is a spiral motion from the centre to the surface, an axillary and progressive motion equally as in the substantial ; by the same reasoning, therefore, we may infer the same cause and effect. Therefore it may be affirmed, without any room for doubt, that the point may become an active in the same manner as a substantial; but as in a point nothing exists but what is simple, and which, therefore, escapes all geometrical apprehension ; and also as there is nothing in it which can be presented to the idea by lines, but only by way of analogy with geometrical lines, I have purposely omitted all description of its active ; although it must be acknowledged that the point may become an active in like manner as the first substantial.

From analogy and comparison with the active of the substantial we may in some measure conceive what is the active of the point, namely, that it is a point impelled into motion by its own internal force ; and indeed into concentric spiral circles, by means of which a most perfectly exact surface is formed. Still, however, we can conceive of nothing substantial in this active except motion ; inasmuch as the point cannot be said to be substantial, though by the highest degree of motion it becomes, as it were, substantial. The motion of this active, however, is almost pure motion, and consequently surpasses every degree of velocity. It may

thus be said to be the most perfectly active; because this motion, which is almost pure and surpasses every degree of velocity, seems capable of imparting a substantial virtue to its simple ; whence it follows also that this point, in consequence of its motion with indefinite velocity, can be present, as it were, in any part of its surface in an instant. Moreover, of this active it may be said, that it has no dimension ; neither breadth, nor depth ; that an infinite number of them may be present in one space; indeed, that they fill all space both the least in the world and the greatest; so that it is, as it were, an entity everywhere present, filling the whole world in its smallest spaces ; in consequence of which there cannot be said to be any vacuum, for whatever space intervenes between the most minute entities may be occupied by this active. That these actives may in like manner be in motion without encountering or interfering with one another; that they may represent any figure, and may accommodate themselves to any angle ; not to mention innumerable other things of which we have spoken in our observations on the active substantial, and which, on account of the simplicity of the point and the purity of the motion, cannot be geometrically conceived. Since, therefore, things which are so near to what is infinite, and which, as it were, derive their origin immediately from it, are remote from all geometrical and finite apprehension, we must pass on to the mechanical part of the subject, and to the contemplation of the world.

## CHAPTER VI.

THE FIRST AND MOST UNIVERSAL ELEMENT OF THE WORLD-SYSTEM, OR THE FIRST ELEMENTARY PARTICLE COMPOUNDED OF FINITES AND ACTIVES ; ITS MOTION, FIGURE, ATTRIBUTES AND MODES; ITS ORIGIN AND COMPOSITION FROM THE SECOND FINITE AND THE ACTIVE OF THE FIRST FINITE ; IT CONSTITUTES THE SOLAR AND STELLAR VORTICES.

Thus far in our world we have two kinds of particles ; the one most highly active and endued with all possible power of motion ; the other altogether passive, and endued neither with moving power nor with local motion; whence also the one is plainly contrary to, and the reverse of the other. The active always acts and impels. The passive is always acted upon and resists. One is most perfectly mobile ; the other in its place, in regard to local motion, is inert. The question therefore is, what can be produced from two entities so contrary to each other ? For the one cannot as yet be in the same place or space as the other ; the one flies away, as it were, while the other pursues. Consequently they cannot be in the same world, unless they are so separate that the passives may occupy their place and the actives theirs.

Before, however, anything elementary can exist, it is necessary that in the world there should be two things, one active and the other passive ; one which is perpetually in local motion, another which is not in local motion. Without these two things no third can be produced which shall partake of the active and of the passive ; in a word, nothing natural can come into being. For nature is the union of the faculty which bodies have of acting and being acted upon, with the power and force of inertia. Unless the active were

a something separate, the passive a something separate, and both together constituted one body, there could be nothing in agreement with nature. Nothing proceeds from pure Unites but what is similar to them; from the actives of the first' finite, nothing but what is active; there is need, therefore, of the two for the production of natural bodies.

Since, therefore, there now exist in the world only these two bodies which are so adverse to each other and so separate, and since in the one we have the highest energy and activity, in the other the highest inertia and passivity, we cannot possibly conceive them to be so separated, but that they must unite into one body. For if the actives perpetually act, and the passives perpetually suffer themselves to be acted upon, there must necessarily arise a third body, so that the actives may always be enabled to act and the passives to be acted upon. For if one kind perpetually impels the other, and urges them at every angle into every place, it at length urges them into an arrangement in which they are exempt from all the influence tending to remove them further out of it.

Since, therefore, the one does not cease to act and the other to be acted upon, we may proceed, before each comes into the situation adapted respectively to its action or inaction, to inquire what this arrangement or figure of arrangement may

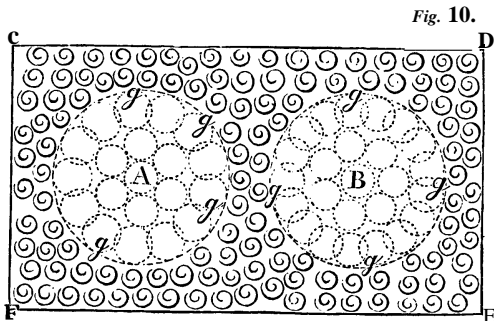

be, so that each may remain in the space of this figure and the force of each also continue. Let A and B be spaces filled with

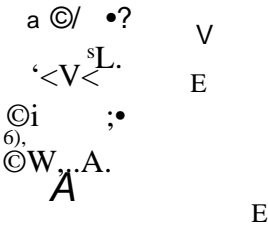

pure actives, around which are finites or passives. Since the enclosed spaces A and B do not cease to act, till those which surround them are reduced to such an arrangement that they can perform their common motion in one and the same space, it follows that the figure which results is similar to fig. 11 ; the internal space of which,

or EEE, consists of actives, and the external surface ABCD, purely of finites.

We may also assign a mechanical reason for the existence of such a figure, resulting from the conflict of two entities so different from each other. For if, fig. 10, the space AB, consisting of pure actives, perpetually acts upon the surrounding finites *g, g, g, g*, these surrounding finites must necessarily be driven in motion round this active space ; if they are put in motion it must be such a motion as accords with their figure, in passing into which one follows the other in a connected series. This motion round the active space cannot be any other than one which produces a spiral and circular figure. How it is that such a motion accords with the figure of the finites, will be shown upon mechanical principles in the sequel.

Wherever, therefore, there exists a small volume of this kind, consisting of actives and passives, there must necessarily result such an arrangement as accords with the nature of each ; so that in this arrangement and space each shall subsist according to its own proper force and nature. Therefore these twin-born entities, which are so adverse to each other, coalesce into one figure; although previously to the existence of this figure or arrangement they were perfectly separate.

By means of this new figure there is thus a connection of

each with the first substantial from which they derived their origin. For if from one entity there exist two which afterwards combine into one, then by this one both are connected with the first.

2. The particle thus produced I call the first elementary particle ; because it is compounded of two, one active, the other passive. From these two the particle derives that elementary nature which is the origin of all the changes that follow before the world comes into existence. But to gain a knowledge of this particle, we must have a definition. It may therefore in general be defined as being the first elementary particle, compounded of the second finites and of the actives of the first finite, possessing a perfectly impressionable and elastic surface. Its other essentials follow from these ; we must, therefore, treat of these separately.

3. It is an elementary particle compounded of the second finites and of the actives of the first. For the actives cannot of themselves form a volume, because they cannot be in contact with one another; for one cannot be in contact with the other ; though one surface may pass through another promiscuously, and though, as occasion may happen, there may be in the same space either more or fewer ; besides which their surface must be diminished. For the surfaces of these actives are only similitudes, representations, and ideas of surfaces, of which there may be in the same space a greater or less number. Hence they do not constitute any volume, but only occupy space; provided there be surrounding finites to enclose the space. This space may be called an active space, or a space of motion. But there is no space which is full of contiguous particles, unless so far as it terminates in the finites which surround it. Hence we arrive at a boundary of space, yet not resulting from the actives, which terminate nothing; but from the volume of the finites which surround them. This particle, therefore, consists of second finites and the actives of the first finite.

4. The second finites constitute the surface, and the actives

of the first finite occupy the internal space. In no other way can they combine into one particle than by that of an arrangement- in accordance with the nature of each, that is to say, with the motion of the active and the inertia of the passive, the actives occupying the internal space, and the passives forming a certain surface round it. Thus may the actives, together with the finites which are around but apart from them, flow, as it were, naturally into a certain surface. The mechanical principles by which the finites suffer themselves to pass into these surfaces I will explain in the sequel.

5. The surface of this elementary particle is held in a state of suspension and equilibrium by these two forces. If there is motion, then nothing which is continuous can be produced without equilibrium. Equilibrium is the principal means by which two things in motion can be kept in perpetual conjunction. It is by equilibrium that they come into that arrangement, and by equilibrium that they are preserved in it. If this equilibrium is not most perfectly exact, the bond of connection is broken, and the composition, as- such, perishes. All concordance, agreement, and unanimity, is therefore the result of equilibrium. On the most perfect equilibrium depends the perpetual preservation of arrangement and form. Equilibrium is the third or fourth analogue or proportional which results from the degree of motion in two or more bodies. A product of this kind cannot be obtained by the analogies of the antecedent motions except by means of space, extension, arrangement and form ; all of which are present if equilibrium is obtained. The essentials, therefore, of equilibrium are the same as the essentials of two or more motions from which is obtained a product which exists only from essentials that as yet have no existence, nor indeed do exist until the equilibrium is obtained. In two motions there are present potentially extension, space, arrangement, and figure ; but yet these do not actually exist till each motion proceeds to its equilibrium. To this it proceeds by forms, spaces, and arrangements ; yet it cannot stay in any space, form, or arrangement, before it arrives



at its ultimate or true equilibrium. Now it is a primary thing in this elementary particle that the essentials of equilibrium should be present. For there is space, being that which the actives and finites occupy at the same time ; there is expanse or surface, being that which the finites form ; there is an arrangement of parts, and in like manner, form. In regard, therefore, to the equilibrium of the surface, we observe that it cannot exist between two forces unless there is as much pressure on one side as on the other. Unless there were an action of this kind on the extremely thin surface of water, bubbles could not exist in the air. Unless there were equilibrium of pressure on all sides, no vapour could maintain the surface of its particles, nor ascend into the upper regions of the air without being dissolved ; no liquids could be formed by the fire into expanded vapours, and be wafted into the atmosphere. And here let it be observed, that the surface itself is intermediate between the force pressing from without and the force pressing from within. There could be no circular cavity or spherical expanse in fluids, unless within there were equality of pressure all round. There could be no convexity, unless the reaction on one side corresponded to the action on the other. Convexity itself is a sign of a perfectly equal pressure on both sides. In this way then the equilibrium of a surface is acquired; in this way a surface may be continuous, and acquire and preserve a certain natural arrangement of its parts. With regard to internal force, this we find in the enclosed active space. If this space consists of actives only which continually act, and which can do so in every direction, we are here supplied with a force on one side of the surface to which some force on the other ought to correspond.

Now with regard to the force on the other side, or the reacting force, we have observed in a preceding chapter that there is an active belonging to each point which occupies all the least spaces and fills the interstices lest there should be anywhere a vacuum. This active is present between every

one of these elementary particles, and acts upon the convex surface and perpetually reacts precisely as the internal force of the actives acts : the surface is thus kept in equilibrium between two forces. Since therefore there is an acting force directed from the actives toward the concave surface, and an acting force directed from the finites toward the convex surface; since also there is a figure belonging to every force in the surface or to every particle, mechanically conspiring to this and to no other arrangement; it therefore follows that there is an absolutely exact equilibrium, by means of which the surface is perpetually kept in its own and natural arrangement, as it were, and by which it can exist under any motion ; neither can it ever be destroyed, unless the contiguity, either in each individual particle, or else between the finites constituting the surface, begins to fail.

To the above force we may add a force on the external part of the surface, arising from the reciprocal pressure of every particle according to the altitude. This pressure becomes mutual, as soon as the arrangement of the parts is formed by motion, and, by means of this arrangement, the vortical figure. In the sequel we shall explain the mechanism of the finites which constitute the surface ; we shall show how they perpetually tend toward the interiors, so that the superficial expanse itself, consisting of finites, is in a certain perpetual reaction against the force of the actives which are fluent within. In this manner then we see the surface of this first elementary particle to be in a state of most perfect equilibrium and balance; so that no surface can be in equilibrium with greater exactness, more particularly as nothing is enclosed with the actives which can possibly change in any way their moving, force and motion. And much more must this be the case with the actives of the point, or with the finites which trace out the surface, and in regard to which no means can as yet be conceived that can produce a variation. Hence it follows, that the surface may be said to be expanded by the actives enclosed in it; also that

the surface, in equilibrium between two forces, has its natural arrangement.

6. This surface is most highly impressionable and elastic. This is evident from the fact that there is nothing in the active—space within, which is contiguous ; for actives cannot present to us anything really contiguous. They are only the similitudes and representations of surfaces, which may apparently be in contact with one another, but are not really so. They are only the phantoms and ideal forms of surfaces. They are only the motive forces of certain extremely minute substantials which represent themselves under the appearance of figure. One of these figures may therefore pass through another wherever it may be, and thus a thousand superficies may flow through and across a single one. In a word, there is nothing contiguous presented to us either by these figures or by the actives. Since, therefore, there is within nothing contiguous which exerts pressure, but only similitudes of surfaces or moving forces in effigy and figure, there is consequently nothing within which resists, except the action of each enclosed active, which by its local motion presents the illusion of the form of such a surface. In a word, since there is nothing within which is contiguous, but only what is most perfectly active, which moves and turns every point with the most perfect potency, what other result can follow than that the surface formed by these or by an active space of such a kind, yields without resistance ; is in a moment impelled toward the interiors ; is as it were sentient of every external force, or is receptive of every possible impression ; is in an instant and in every point able to bend itself, as it were, towards its interior space, where there is nothing resisting and contiguous? In a word, its surface becomes most perfectly impressionable, nor is there anything more so. If however, there was anything contiguous within, and if the surfaces were real and capable of being in mutual contact with one another, then this surface, expanded by what has contiguity, could not be impressionable, and turn itself instantaneously toward the

interiors, unless also that which had contiguity and was within were equally yielding. Now what is contiguous and within, could not possibly yield, unless every surface or particle constituting what is thus contiguous were equally impressionable. But every particle cannot yield, unless there be something else within which is not contiguous. We arrive, therefore, at this conclusion, that there can be no yielding in any surface unless there be something within which is not contiguous, but which nevertheless acts and exerts pressure as if it were contiguous.

Since, therefore, these actives do not resist as if they were contiguous, but act and push in every manner, it follows that if every point of the surface were pressed by some external force toward the interiors, it would immediately leave the natural arrangement of equilibrium which it ought to maintain with the enclosed actives, and begin to lose its equilibrium. Inasmuch, therefore, as the points constituting the external surface cannot subsist together without equilibrium, or the figure, arrangement, and expanse from which the equilibrium exists, they are impelled by the enclosed actives, or the active space, into their former and natural place; the former and natural figure being thus immediately restored, and, after this exercise of force and opposition, becoming what it was before the pressure was applied. The surface, therefore, is not only most perfectly impressionable, but it also very quickly returns to its former natural state; or what is the same thing, is most highly elastic. For its elasticity consists in this, that it immediately rebounds into the place from which it was driven and is the same as it was before. This principle may also be illustrated mechanically; for if the enclosed actives are capable of acting in every possible manner and direction then they perpetually act upon that point which withdraws itself within the figure, and by reason of which the space is rendered unequal, or some part of the equilibrium is destroyed. Therefore as the actives are always present with their motive force, they cannot cease to act till that point of the surface

which was displaced by the external force is again brought back to its place.

Nothing, therefore, can be more elastic than the surface of this elementary particle. For the surface is, as we have above stated, perfectly equipoised, and consequently nothing antecedent to this can surpass its elasticity. Now if to this is added, as we shall explain in the sequel, a perfect similarity of the finites in the surface, and hence a motion and arrangement of all throughout the absolutely similar surface, then there can be nothing which can describe or trace out this surface more exactly, and preserve it in this state. In consequence, therefore, of the forces pressing equally on all sides, this surface must always exist in a state absolutely similar to itself, and must almost instantly return to the arrangement from which it had been disturbed. That its elasticity is nevertheless more perfect in its state of expansion than of compression, will be seen in the sequel.

Its rebound is equal to the pressure, or it recoils and reacts with the same force with which it is pressed. This follows in general from the fact, that it rebounds to the same state from which it had been driven by some force, and especially from this, that the more it is pressed the more it presses back and reacts ; and that the reaction is less when the pressure is diminished. If the surface is pressed toward the interior, the enclosed actives immediately react and restore its figure; if the surface is pressed more forcibly toward the interior, the actives still more strongly act or, as it were, react. If the surface is much bent inwardly, the more numerous are the points of the surface within the active space which can be acted upon. If it is not much bent inwardly, the fewer are the points within the active space upon which it can press and exercise any action. Its rebound, therefore, is always equal to the pressing force, or it rebounds with the same force with which it is pressed. We may here add the observation made in a preceding chapter concerning the actives, namely, that a larger number of actives act more

strongly than a smaller, and consequently still more strongly if they be driven within a narrower space, because then more may be imagined in an equal space than in a space more expanded. It follows, therefore, that the reaction is as great as the action. How it is that under every pressure the surface remains similar to itself, and that no tremors can be imagined in its expansion, will be explained in the sequel.

The sum of the forces before and after collision is the same, or in every collision or impact the quantity of force is preserved. This will be seen from the figure and mechanism of the particle, better than from all the demonstrations which might be adduced. This particle is, as it were, the very figure of elasticity ; for since the forces of its rebound and elasticity consist in the action of the actives which are within, and since the actives are nothing but motive forces in figure or formed into apparent surfaces, since their sum and quantity after the collision or pressure remain the same as before, it follows that the sum and quantity of forces are also the same before as after the collision. The forces, however, are increased in proportion as the space is lessened by the pressure or impact, and these increments of the forces are inversely as the spaces.

The surface when liberated from the compressing force is immediately restored, that is to say, in regard to its expansion and space. That in every degree of compression the figure remains similar will be shown in the sequel.

7. The weight in the surface is imperceptible, for which reason it cannot be said to lose any; and in the particle thus expanded we cannot conceive of any momentum but what is the smallest possible or none. Momentum is compounded of the masses and velocities, or is calculated from the mass and the magnitude of the velocity. If the body be perfectly elastic, it will be, as it were, without weight, for it is thus rendered more ready to yield to the reciprocal force of the elasticity. The finites themselves which constitute the surface of this particle, inasmuch as they are the smallest

possible and proceed directly from the smallest substantials, occasion the surface to have the smallest possible breadth ; there is also nothing contiguous to exercise repression, but only a certain active space which acts merely and does not—resist; the surface also lies between two forces kept in a perfectly equal and natural balance. In such a medium, therefore, (if we may so call that which is none), there can exist no weight as a cause of resistance. The lighter the medium and the subject of contiguity, the less is the resistance, or a less amount of resistance is perceived. In water the weight of a sailing ship is not perceptible ; still less is perceptible the weight of bodies floating in the air, whose particles nevertheless are in contact with one another. In the present case, as there is nothing contiguous, so there is nothing resisting, but only that which acts, and this not only backward but in all directions. Therefore as nothing can be conceived in an active space which can be described as resisting, so there can be no weight in the surface or series of finites.

8. From these observations it follows that nothing can be conceived either without or within the surface of this particle as resisting, but only as acting. For by their action actives resist not only at one angle but at all angles ; therefore they cannot be said to resist but to act; for resistance implies direction to an end, and a place from which the resistance comes. Since, therefore, there is nothing resisting, the medium of which the space consists is as nothing and as without resistance. In such a medium we cannot imagine any weight because there is no resistance. By the same continuous action, by which the actives formed the surface, by the same will they preserve it. It was by their action that they came with the finites into their arrangement or equilibrium, and by the same action will they preserve it. The cause of existence is the same as that of subsistence ; the cause of formation the same as that of preservation. For if the finites went within the active space they would be immediately acted upon, and they could not be sent back in any other direction than

toward some point in the surface. Wherever they came back they would come to their like, and consort with them into the same motion. Now since there is nothing to offer resistance, since there is nothing in the active space which can be said to be heavy or to have weight, and yet since there is elasticity, it follows that the resistance consists in the action of the actives not determined to any given angle, but still that it may have a determination as if it were resisting; for since the force acts in every direction, there must be a force acting in that direction in which the resistance is conceived.

9. The finites which constitute the surface are connected together in a contiguous series. They cannot possibly be disposed into any other arrangement and form than the spiral; extending, for example, from one pole by spirals forming a surface into another, evidently in the same manner as in the finites themselves. From the same cause the same effect follows ; from the same seal the same impression. In the surface, therefore, of the elementary particle every finite or separate part is connected as to its poles with its proximate finites.

10. In this surface the force and effort of all the finites are always the same and perfectly equal. If the finites are connected with one another, then what happens in one must necessarily happen in another. By reason of contiguity what happens in one is made perceptible in all. If one is compressed, the same degree of compression is by connection communicated to all. If by reason of a smaller degree of compression some are free to perform an axillary revolution, so are all the others. Such as is the axillary motion, such are the force and tendency to a local motion. Therefore in the surface of this elementary particle the force and effort of all the finites are equal.

11. The motion and rotation of one finite in the surface of an elementary particle is the motion and rotation of another and of all. The finites or particles which constitute



the surface, cannot be connected here differently from what they are in the finite itself; they are connected, that is to say, as to their poles and into a spiral figure; from the centre to the surface, and from the surface to the centre, by means of spirals, and from one pole to another. There is thus a connection between them all. If now in this arrangement, connection, and contiguity, one is moved about, so are all in contact with it. If the axillary motion is diminished in one, by means of the connection it is diminished also in another, and in all that are in contact with it. Thus do all the points in the surface, in consequence of their connection with one another, experience the same changes, and this by a natural and mechanical necessity.

12. The change of state in one finite causes a change of state in another, throughout the whole surface of the elementary particle. This follows from the connection of their first principles, and from the causes adduced in the theory of each finite. In every separate part or finite which constitutes the surface of the elementary particle, there is, as we have above stated, an axillary motion, a progressive motion of the parts, and, if there is space for it, a local motion; there are also a spiral figure, poles, and other properties which we have predicated of the first finite in our theory of its formation. These finites are mutually connected, and this at the poles where several of the parts are in contact with one another. If they are connected, then, when one is in a state of compression, all are reduced within narrower bounds, because all are in series and connection. If they are compressed as to their poles or equators, their axillary motion is retarded or stopped ; they cannot have any axillary rotation if they are compressed by their neighbours ; if they are compressed, the progressive motion of their parts is impeded or stopped ; if, the axillary motion is diminished or stopped, in the same ratio its effort or tendency to a local or second motion, or its power of actuating itself is diminished or stopped ; *for* it is the axillary motion which is the cause of local motion or of

active force. The forementioned finites, therefore, in the surface of the elementary particle, may with facility continue to exist, because, with respect to a great part, they are destitute of all active force. Thus, in consequence of the connection between them, the change of state in one causes a change of state in the other.

Change of state in each particle or finite of the surface proceeds from an external cause and from compression by means of contact. All the motions that are in any finite, are mutually dependent on one another. If the axillary motion is diminished, so is the progressive, so also is the effort to local motion ; for the axillary motion is the cause of the local. The effect ceases if the cause ceases. The effort or tendency to a local motion is plainly such as is the axillary motion; the axillary cannot be stopped except by contact and compression that is to say, by some external cause. If the finites are compressed as to the poles or equators, the tendency, forces, and motions of all are diminished.

13. Since these finites are in connection one with another and constitute the surface, they cannot possibly become actives ; but they generally remain passive and inert. If there is a mutual contact between them, then their axillary motion is retarded or stopped by this contact, in the same way as by compression ; and consequently, together with their axillary motion, their active force and tendency to a local motion. Thus do these finites in the surface of the elementary particle, become more or less passive and inert, according to the closeness of the contact.

14. If the finites of the surface were disengaged from their series, or liberated from their link with their associate and neighbouring finites, they could not become actives and betake themselves to a local motion, but must immediately pass into some series of the proximate surface, and join themselves to other finites of the same kind. They have no space for spreading and running out among the elementary particles ; much less have they any space there except what those circles require,

## THE FIRST ELEMENT.

which they must naturally describe. There is, therefore, no space left between the contiguous elementary particles for them to perform even a single rotation ; neither have they sufficient room interiorly with the actives of the first finite.' Nor is there any number of them by which their force can be rendered stronger. When, therefore, they are liberated from their connection with the other finites, they have no power of excursion; but must betake themselves into the structure and series of the proximate surface, and there stay, and with their fellows describe some associate surface.

15. Nevertheless, from one elementary particle there may exist many actives, which, together with the enclosed actives, may occupy a larger space. This will be seen in our observations upon the active of the second finite.

16. A small volume of finites may present a large volume of elementary particles. For the elementary particles are extremely expanded; and because their finites constitute only a surface, a small volume of finites may consequently supply an infinite number of such surfaces and an immense expanse ; just as a small volume of water may supply a large volume of vapour, as is well known from a variety of experiments.

17. This elementary particle, consisting of finites and actives, may be compressed into one still smaller and smaller; and again it may be expanded from a smaller into a larger. Since the surface is poised between two forces, it follows that in whatever space it is, it can, as such, maintain its equilibrium. Since also this surface is most perfectly yielding, it may consequently withdraw itself into a smaller space. The finites themselves are of such a nature that they can move in aggregates ; in an entire space as well as in any superficial expanse. They can, therefore, flow through any surface, as well when compressed into a smaller or expanded into a larger space.

18. In every degree of compression the similarity of the surface is most exactly preserved, notwithstanding that the surface

may be larger or smaller. An active space can be surrounded only with a perfectly regular figure, so that all the actives or their apparent surfaces may so fall upon that cavity as not to have anything angular upon which to exercise their force. Now when all the finites have passed into such figures, that there is nothing anywhere upon which they may impinge as angular, their figure is then the one which is the most perfectly adapted to their space and motion, and this is one cause of the similarity of figure being preserved. The other cause is to be found in the actives of the point, which flow extraneously and act upon the whole external surface with a perfectly simple and almost pure motion ; for these actives leave no place empty, but exercise a perfectly pure action upon all, and almost in an instant. Nor do they allow of any angle in the surface upon which they can act more than upon any other part; therefore also we have an intrinsic cause for the superficial expanse always keeping perfectly similar. Nor can the finites which compose the surface progress according to any other than their own proper figure ; for whatever be that to which one finite tends, into the same tends the other, and all simultaneously or the whole surface. Since, then, an enclosed active space does not permit itself to be circumscribed by any other than a round figure, nor likewise the actives of the point which perpetually act without, nor the finites themselves which form the structure and expanse of the surface, therefore nothing can exist to render the figure dissimilar, whether the particle be under a greater or less degree of compression.

19. The series of finites flowing through the surface, may flow in a simple, double, or triple order, according to the degree of compression by the adjacent finites. During the compression, the surface must converge altogether toward the interiors, since it cannot retain its former expansion ; for the surface consists of finites cohering in a series and flowing in contiguity ; hence in any compression, the expanse becomes less, and the excess must betake itself somewhere, which it can do only in

the direction of the interiors, by means of spiral circles; hence, it would seem, the surface may be doubled and tripled ; nevertheless, however duplicated and multiplied, the surface retains its figure, and the Unites their arrangement and piTP—gression : for this they are enabled to do from the centre to the circumference as is the case with the finite itself; and much more from one circumference to another.

20. In a state of compression the elementary particle begins to form certain polar cones towards the centre. In proportion to the

Fig. 12.

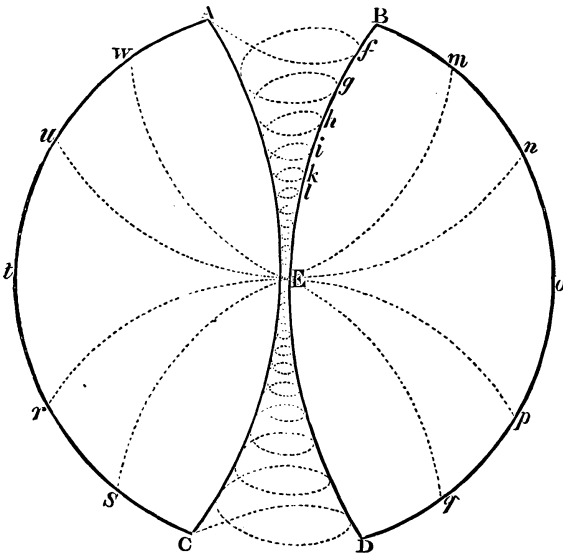

degree of compression, it becomes more and more like some finite in which the points or particles flow from the centre to the circumference, through the poles toward the centre, and so on always reciprocally. Since, then, it more and more resembles the nature of the Unites or the figure of motion of the particles in the finite, the superficies consequently, according to the degrees of progression, betakes itself towards the interiors, doubles and triples itself, until at length it evidently becomes like some finite, so as to have poles or polar cones. Such an elementary particle will

perhaps not be unlike fig. 12, where the whole space consists of fluent finites, as also the space  $AECsr^w$ , whose polar cones are  $AEB$  and  $CED$ . On this subject, however, we shall speak in the sequel.

21. In the greatest degree of compression the elementary particle evidently changes into some new finite. Here is the limit of compression. According to the mechanism of their motions, the elementary particles cannot change their figure into any other than one like that of the finites, on account of the sameness of the nature and force of all the successives. Of this, however, we shall speak subsequently.

22. The particle thus ceases to be elementary. For there is no longer any active space round which the surface flows ; there is no surface which can be more completely compressed and expanded. The enclosed actives likewise have gradually banished themselves. Together with the surface have gradually disappeared all compressibility and all elasticity, and consequently everything elementary.

23. The enclosed actives have a greater power of acting and reacting upon a compressed, than upon an expanded particle. If they are reduced to a smaller space and within narrower boundaries, then, according to what we have above stated, they have a stronger power of acting.

24. Under too great a compression, the enclosed actives begin to lose their force. For if no more space remains than is equal to the circle or surface which the active describes and figures, it has then no longer any room for running out; and if it be deprived of this, it follows that it is deprived of its force, which consists in its liberty to run out according to its innate force. Moreover, by means of complications of series or surfaces, the sides of the surface begin to thicken. Hence also the actives cannot exercise such force upon them as upon a surface consisting of one or two layers or series. The more, therefore, they are compressed, the less is their force.

25. Moreover, in the greatest degree of compression the

actives evidently disappear; they attach themselves to the finites which occupy the surface, and plainly cease to be actives.

26. It also follows that the elementary particles cannot be destroyed by any degree of compression, but that they ultimately become a new finite. The series of finites constituting the surface approximates more and more to the figure which they are naturally capable of having and representing by their inherent motion or force ; and this figure is similar to that of every finite.

27. In their greatest degree of expansion they may be destroyed and dissolved. By their expansion the connection which one finite has with another is ultimately dissolved ; and consequently when this takes place, the expanse can no longer be considered as contiguous, but as a rarified and dispersed number of finites, which, liberated from contact, begin to take on a more rapid axillary motion and to become actives ; nor can they take the same path, or have the same periphery and surface, as when expanded by connection. By too great an expansion, therefore, they may ultimately perish.

28. They may be dissolved also by actives acting upon them from without. For if there is an active space without, and such an elementary particle approaches and enters it, it might be possible for it to be dissolved by the force of the surrounding actives ; but this will not be the case, if it remains in a volume and in contact with the other elementary particles.

29. These finites may become actives. For when set free, they have the force which the finites have, or the first substantiate of which they are compounded. They may, therefore, become actives and occupy space, in which they may similarly exercise their active force. Of this, however, we shall speak in the sequel.

30. Or, otherwise, when at liberty they may pass into the surfaces of others which are similar, and there continue their motion. For they cannot perform their active or local motion between their elementary particles, inasmuch as the interstices are too small to allow them to perform their entire gyration ;

hence they run with a simple force upon the convex limits of the elementary particles; and by falling into them, are received within their series and superficial expanse as their companions. In this manner they become passive and inert.

31. In this elementary particle there may be presented all possible degrees or kinds of elasticity ; but according to the degree of compression. If these elementary particles are compressed, their surface is immediately doubled and multiplied, and made capable of exercising a stronger resistance. The actives also, confined within a smaller space, receive a stronger power of acting; therefore the elasticity which is greatest in the greatest expansion of the particle, is gradually rendered more resisting and stubborn. Hence it follows that they are more impressionable when they are expanded, and less so when they are compressed. In the highest degree of expansion their surface is most highly impressionable, becoming gradually less so the more it is compressed ; till finally in the highest degree of compression it becomes hard and non-elastic and at the same time ceases to be elementary. For when the elasticity ceases, then also that ceases which is elementary, or which renders the particle elementary; or, in other words, which enables it to move in particles, to apply itself to every locality, to form a vortex and exercise an infinite number of other functions, which, if the elasticity of the parts he maintained, result from their acting in a volume. For the actives have disappeared, so that now nothing remains active ; and yet without an active nothing elementary can be conceived.

32. One elementary particle touches and presses upon another and by means of this contact forms a certain continuity of one particle with another. As every particle possesses a surface and occupies its own space, it may likewise touch another particle. Without contact nothing contiguous can be formed. It is from contact that contiguity exists ; and, together with it, all elementary nature, which has its existence and consistence in contiguity. The greatest contact, or that of the



greatest number of points, appears, according to the mechanism of the figure, to be around the poles; at the equators, however, where the particles are roundest, the contact is only in the smallest possible point.

33. These elementary particles cannot be in contact, except in a manner accordant with the motion of their surface and their figure. As their elementary principle consists in a capability of being moved in particles and also in volumes, so that the motion of the volume is as that of the particles and the motion of the particles as that of the volume ; inasmuch also as by reason of the compressibility and elasticity of every surface, they can be in every motion and apply themselves to it, and in like manner touch one another only in one point at the equators, it follows that they cannot be put in motion one among another except in a manner conformable to the motion of their surface and their figure, all other motion being contrary to them, and either stopping, disturbing, or impeding their great mobility, and consequently introducing irregularity into their general motion. This circumstance, however, being purely mechanical, and following mechanically from the motion of the parts, there is no need for further observation upon it.

34. These elementary particles cannot touch one another except when arranged in parallel. The poles of all are in a parallel arrangement or line, as also all the larger and lesser circles ; and they are kept in this parallelism by the mechanism of their figures, and their contact at the poles. Their arrangement is of a spiral form, and similar to the arrangement of the parts in every finite ; being, as it were, a kind of spiral twist. Since, therefore, in the surfaces of all the elementary particles, the arrangement is similar and of the kind we have mentioned, it follows by mechanical necessity, that their mutual arrangement must accord with the current of these particles as they run into a spiral, and that naturally they are simultaneously moved in accordance with this general fluxion of all. Thus it is that they connect their sides, and unite in

contact, and are carried consentaneously into every larger motion. In a contrary arrangement there arises a reaction, a kind of opposition between the particles in contact, and a disagreement, preventing the motion of the parts in each from being free, and producing a disturbance of the equilibrium. The very mechanism of the arrangement and figure, therefore, occasions the particles to move among one another with great ease, if the second motion of one surface is the second motion of the other; that is to say, if their arrangement is according to the arrangement of the parts in the surface and according to their figure ; as when helices are in motion among one another ; in which case they must attach themselves to one another according to their motion and figure. It is at the poles principally that the parts are in contact; at the equators the contact is only in one and the smallest point. Consequently nothing can so mechanically direct the position of every particle in motion, as a contact between several parts, and which is to be found only at the poles. Hence it follows that all their larger and lesser circles, as also all their poles, are exactly parallel with one another.

35. Nevertheless they may be easily displaced from their position ; but they immediately return to it as their natural one. Since their conjunction is only in a few points, and since the particles themselves are most perfectly compressible, they are consequently not so firmly connected with one another but that they may be easily dislodged from their situation by any external force. Because, however, their mechanical arrangement is in accordance with their axes, and consequently is their natural one, they spontaneously relapse into it after displacement.

36. Several of these particles, or a volume, when put into motion, cannot move about otherwise than in accord with the parallelism or arrangement of both. This is a consequence of what has just been said. For if a volume of particles is circumfluent, all of which are by mechanical and consequently natural force kept in the same position, the whole volume

cannot be circumfluent in any other way than by keeping the same arrangement which the particles severally possess. For each particle contains the cause of the whole; the whole follows the direction and determination of each one. The motion of the volume, therefore, can be no other than the motion of the parts; that is to say, the several axes are in the motion of the volume, and are the axes of its motion.

37. From the motion of the volume of the particles a vortical motion exists. And no other particles can be better adapted to a vortical motion than these, by reason of their figure and elasticity. Not only are they kept mechanically in their arrangement, but also conformably to it one moves when the other moves. In consequence of this connection, though on so minute a scale, the one brings the other into its own motion. All, therefore, which possess a similar force, figure, and mechanism, are easily brought into the same motion ; and because the motion is circular, it is vortical. The very high elasticity is also another cause of their perfect aptitude and susceptibility to a general motion. By their elasticity the particles are suited to move in every place and under every degree of compression, that is to say, they can move under any force, pressure, and weight so that they can continue similar in the space and figure of their motion ; and if any inequality be impressed upon them, it becomes distributed equally through all. Since, therefore, by reason of their very high elasticity they can always continue similar in figure, they are consequently all most highly adapted to one and the same general motion ; and, as we shall show in the sequel, they all spontaneously flow into this motion, if only a state of action be supposed. Since, therefore, the superficial figure of all is most exactly alike, as also the motion which forms this figure ; since all have the highest possible compressibility and elasticity, and exercise the same common effort, it follows, not only that all have the greatest aptitude and tendency to a general or vortical motion, but also to a continuance in it, as it were, without any tendency backwards.

38. Upon the exercise of the slightest force they naturally flow into a vortical motion. For since they are not only most highly susceptible but also most highly suited to a common or vortical motion ; since the form of each particle respectively conspires to this and to no other motion ; since also all tend to a local motion, as will subsequently be shown ; it follows that merely in virtue of the origin of their motion, whatever that origin may be, they tend to no other than a vortical motion : just as the least sound, the least commencement of motion in the air, sets a volume of its parts into a wave motion from the centre to the circumferences and on every side circularly \ as we see also in water and in every element whose phenomena can be observed by the senses. This tendency is more particularly observable in the present case ; in which one particle, as it were, assists another in the performance of the same gyre as its own; a gyre into which, in consequence of their elasticity, all most readily and similarly flow ; therefore from the least beginning of motion they flow spontaneously into a vortex. If their motion is vortical,, there must be a centre of motion from which it begins ; and the distances from it form its peripheries.

39. There can be no other vortical motion among the particles than such as is in accordance with the figure of each particle,, and constantly refers itself to some axis of motion or gyration ; likewise the vortical motion forms a certain polar axis. Since all the particles have their poles and axes, according to which they arrange their situations parallel to one another, they also so dispose their general motion that this also shall have a like axis to which to refer itself.

The circles of vortical motion among those elementary particles which are farther from the centre inflect themselves more and more till they come into a right line with the axis. For if these forms and surfaces, which have a perfectly circular motion, were without an axis, they would then run into circular peripheries and surfaces ; since, in this case, there would be nothing dissimilar

to drive them out of this course into any other. But if the figures and surfaces are axillary, and if their arrangement is parallel to their axes, they will then recede from these peripheries, and turn themselves in a direction parallel to their axes ; a result which follows from the mechanism of the parts.

This happens until the vortical motion ends in a right line, and so quite vanishes in a direction parallel with the axes of the particles. If the circles, in the course of their progressive motion, gradually turn themselves towards the axes which lie parallel to each other, the motion passes from an oblique to a rectilinear direction, or to an arrangement the same as that of the axes.

A vortical motion arises from the exercise of a motive force in a given centre ; and when thus begun from a centre, the greatest motion is nearest to the centre, and the least at the outermost peripheries. Wherever the force of motion begins, it sends the particles next to it into a gyre. At the first commencement these particles always resist the acting force before they become accustomed to the motion, and before they urge the entire volume into the same gyration; for these particles are in contact, and one cannot move without another ; *if* therefore one moves, so will another, so will also the adjacent particles to some considerable distance ; and these also, before they can follow the others into the same motion, must first be urged by the particles near ; but when once moved they spontaneously follow. In the same way the atmosphere, when struck, at first resists, but when accustomed to the acting force, the parts near it pass altogether into the same motion ; for by reason of the contiguity of the parts the motion spreads itself to a gradually increasing distance from the centre.

The polar axis of the particles is the same as the polar axis of the zodiac, and their equators the same as the zodiac of the solar vortex. Because this first element is the most universal, passing through all the vortices, and is a contiguous medium between the eye and the sun as well as all the stars

of the heavens, it follows also that it is the most universal element of our own solar vortex. And since we see in the middle of this vortex a sun, which is most perfectly active and always acting upon the volume of these particles, we cannot come to any other conclusion, than that it is this element more especially which is put into a vortical motion. From the orbits of the planets we learn, that its motion observes principally a greater circle, or the zodiac ; which, according to the principles we have laid down, is the same as the larger circle or equator of each particle, while the poles of these particles are the same as those of the zodiac.

40. Superficial matter or finites, flowing through a surface, may, near the poles, pass into the surface of the neighbouring particle. The greatest contact, as we have said, is at the poles ; because these are perfectly paralied to one another, and the particles are all, as it were, conjoined to one another by the poles. Consequently one finite may, at the poles, pass into the surface of the other. In every particle the polar circles have a certain degree of latitude; hence at the poles they are in contact with one another in many points. The very reciprocation of the motion of the finites, also, through the surfaces, exists at the polar circles ; by means therefore of their vicinity there may be effected a communication of the surface of one with the surface of another, and consequently a passing of the matter of one into the surface of the other.

41. By this translation of the finites and superficial matter from one surface to another, the surfaces of the particles may be diminished or enlarged; that is to say, they may become smaller or larger, and thus may bebrought into equilibrium, in regard to space and weight, with their adjacent and allied particles. The contingent reasons why one elementary particle may not be similar to another may be innumerable. For if the space occupied interiorly by the actives be larger, there results a larger surface and a larger particle. If a larger quantity of finites surrounds either the same or a similar space, it follows that the surface will be in like manner larger or smaller. If

an immense space filled with actives presses a volume of finites into a narrow compass, and gradually forms them into these elementary surfaces, there may be many reasons why one element may be larger than another. In a word, the elementary particles, at the commencement, may be unequal, although we must conceive that, so far as contingent causes allow, nature will always preserve its own identity. Nevertheless, if elementary particles, unequal to one another, come into existence, still they can be reduced into equality with one another by means of the transition of the matter of one surface into that of another. For when by their vortical motion all the particles are brought into a regular arrangement, if, at any distance from the centre and under any degree of compression, they do not all with equal ease flow into the same motion and figure of motion (for they ought all to be equal, since without equality of parts there is no equality of volume) then, by means of the mechanism exemplified by the influx of one through the poles into the surface of the other, they may be brought into equality one with the other, and may all occupy a like space, and have a like quantity of matter or number of finites in the surface. Were I to go farther into the subject of this natural equation, I should open up an immense field for contemplation; and one in which I should have to present to my readers opinions which at first might not appear to harmonize with their ideas.

42. The enclosed actives follow their particle as if in their own natural location, and they are not sensible of the local motion of their particle. The case is the same with the finites which occupy the surface, if there is a local motion of the volume. We cannot conceive of place except in that which has contiguity ; for place has relation to parts in contiguity; neither is there any relation of place where there is nothing contiguous. The apparent surfaces of the actives give rise to no contiguity between them ; for no one surface touches another ; nor does one active as to its figure hinder another ; neither do the parts keep together in real surfaces; that is to say, they can have

no relation of parts in contiguity. Therefore one active cannot be said to be distant from another, unless the distance be conceived as imaginary, and a boundary be presumed in the apparent surface, which, in consequence of the change of place and the varying determination of the active, cannot be supposed. Now since every active, with all its imaginary surface has no defined position, the same is the case with them collectively, so neither do they collectively occupy the entire space. Their place and boundary of gyration is where the surface of the particle is, and collectively they constitute a unity. For the same reason neither can the surface, itself or a whole elementary particle, in its general motion or volume, be said to experience any change of place. For there is no interchange of place between one particle and another.

43. The cause of their compression arises from the action of one upon another, by means of a motion proceeding from some large space occupied by the actives. For if there is a large active space, there is immediately an action, at the boundaries next to the space, upon the circumfluent elementary particles, which in these outermost bounds are agitated by the actives, each according to its nature ; consequently, the motion between the elementary particles is most rapid at the boundaries of the active space ; this motion is passed on from these to the particles next in contact, and consequently spreads around in a vortical form. The greatest motion, therefore, is at the first beginning of the motion. In all other parts, the motion is derived from the particles here situated to the next, from these to the next, and so on in succession.

44. A compression of the particles may arise also from their mutual pressure. When the elementary particles are reduced by motion into a regular arrangement, so that the volume acquires an arrangement in agreement with the figure of each of its particles, there arises hence another pressure which is the mutual pressure of the particles; the pressure of one upon a second ; of a second upon a third ; and so on throughout all the radii and circles of its volume.



For if from any cause, such as that of motion, the volume be brought into a regular arrangement, it will by the same cause be retained in it; for when the cause ceases, there is a cessation also of the effect. All the elementary parts therefore, are put into this motion by the large active space, and by themselves and their own effort into a local motion ; from these the motion is passed on, at various distances, to the contiguous particles. One particle therefore is urged into this motion by another; by this motion one is pressed by its neighbour; and consequently the most remote by the first through the intermediates. By the operation of the same cause, they are perpetually retained in the same arrangement or figure of motion. Hence there is a perpetual action and pressure of one upon the other ; and this pressure is proportioned to the altitude. This pressure cannot exist except in a vortex, or volume in motion, and which is thus brought into a regular arrangement.

45. There is in the volume the same elasticity and degree of elasticity as in each particle. Since the particles throughout the volume are in contact, it follows that in a volume of this kind not only does elasticity exist, but also the same degree of elasticity which is in each particle. For one particle cannot be sensible of anything of which the other is not. The sensation is passed from one to the other in the same manner as the motion. The reason of the motion is the same as that of the pressure, as we have stated above.

46. These particles exert pressure according to their altitude in their vortex. For since pressure arises from the motion of the particles, it follows that where there is the greatest motion of the parts there also is the greatest pressure. It is from degrees of motion that degrees of pressure arise. For it is a law both of mechanics and of nature, that local motion is the cause of action ; or that active force consists in local motion. If the motion is greater at the centre than at the circumferences, there is consequently a greater pressure at the centre than at the circumferences, a pressure which decreases in pro-

portion to the distance from the centre ; therefore both the degrees of motion and the degrees of pressure are to be estimated according to the altitude.

47. These particles also exercise a pressure altitudinally proportional to the base or area subtending the altitude. For if the pressure be according to the altitude, the pressure upon a greater number of parts is greater than upon a less. Upon all the parts of one body the pressure is equal ; if there is a greater number of parts, the pressure is upon a greater number ; consequently the pressure is increased and multiplied according to the number and quantity of the parts that are in opposition ; that is to say, according to the base or area subtending the altitude.

48. They press equally upward and downward, according to the altitude. In all motion and action, the reaction is equal to the action. Bodies that are moved resist with a force equal to that by which they are impelled and urged into motion. And since the vortical motion is in the direction of the circles and the radius, and is also intermediate between the two, it follows that the pressure is the same as the action, according to the altitude; and since the action is the same as the reaction, and the reactive pressure of the particles in the elements the same as the pressure, it follows that the pressure and reactive pressure in the element are equal, as is also the effect produced upon all the opposing particles at the same altitude.

49. These elementary particles do not press so obliquely as air particles. There is another mode of pressure which is According to the axis of the volume formed by the axes of every individual particle ; as will be seen in the theory of the magnet. For there is no contact between parts arranged as those are which we find in the highest periphery, or in the equator; but the contact is principally in the polar circles; hence there arises one kind of motion and pressure which is according to the axes, and another which is according to the equators. All the motion between the axis and

the equator is oblique; and the particles must participate in this obliquity, both in regard to the motion or pressure which is at the equators and that which is at the axes; and this motion or pressure cannot be the same as the motion of direct pressure according to the equators of the particles or to their altitude in the vortex. Of this, however, we shall speak in our theory of the magnet.

The altitude of the particles is only in the direction of the plane of the equator of each particle, or in the direction of the plane of the zodiac of the solar vortex. The equators of all the particles form our zodiac ; the poles of the particles are our zodiacal poles ; hence their altitude is in the direction of their mutual contact, and consequently in the direction of their distances in the plane of the zodiac.

50. This element is the most subtle, the first and most universal, of our mundane system and of the universe in general. Inasmuch as this element is the first, it follows also that it consists of the smallest elementary parts. That it is the most universal, may be concluded *a priori*; because it is the origin of all the subsequent elements ; because also it consists of the smallest constituent parts, can occupy the smallest spaces, and be present where no other element can ; therefore it may without doubt be concluded, that it is also the most universal. We may come to the same conclusion also *a posteriori*; for in the starry heavens we see with the eyes all the stars, as it were, present to us, yet this presence cannot be effected without contiguity. Consequently from reason instructed by the senses we learn that there is nothing more universal than this element. From reason it follows that, in every system, both the greatest and least spaces are occupied by this element; and that this element is of all others the most perfectly contiguous. As all the essentials of contiguity are latent in every particle; as all the particles may be mutually applied to one another, and in consequence of their form and situation may all conspire to one consentaneous motion ; as in virtue of their extreme elasticity

they may accommodate themselves to every motion; so also in virtue of their simplicity they are the first and most subtle element, and consequently admit of the fewest possible modes and variations. Thus from reason, instructed by the phenomena presented to the senses, we learn that it is in virtue of this universal element that all things in the starry system appear, as it were, present. Whenever they do not appear so, it is only in consequence of our being accustomed to measure distances by comparing the angles made by distant objects with those immediately near the eye. It is in virtue, therefore, of this element, that we can contemplate the remotest stars, as also the planets by their reflected light.

51. In this elementary particle, all that had pre-existed is latent, such as the point, the first finite, the second finite, and the active of the first finite. We have thus in a microcosm the whole of our macrocosm ; we have the entire world, so far as it has developed itself, in each particle, in which, therefore, we may contemplate a compendium of the whole world-system. For from a point produced from the Infinite arose the first substantial ; from the first substantial, its actives as also its passive, that is to say, the active of the first finite and then the other finite. Thus does this first elementary particle, consisting of the active of the first finite and also the second finite, comprise within itself all that as yet is active and passive in the world. Thus we have the world concentrated in a single particle. I entreat the indulgent reader to pardon me for venturing to speak so positively of the elements and entities of the *natura prima*, which are so unknown and occult, as if they were objects well known and familiar to the senses. It would indeed be rash in me so confidently to lead him through such an unexplored region, a region of so many clouds and shadows, were I not aiming, through the medium of the principles explained, to arrive at an element in which we are able to make experiments, and which, by help of these and geometry, may be subjected to the most rigorous

examination. When we have arrived at this stage, if it appears that there is a geometrical harmony between the experiments and our principles; if a connection is pointed out between the first entity or simple and the forementioned element, I then flatter myself that I shall have won the assent of my reader ; more particularly as, in the present age, there is no other way left for us to open the secrets of nature.

**A GEOMETRICAL DISCUSSION OF THE FORM, AND A MECHANICAL DISCUSSION OF THE ARRANGEMENT AND MOTION OF THE PARTS AND OF THE COMPOUND, IN FINITES, ACTIVES, AND ELEMENTARIES.**

We are now at liberty, for the first time, to explain the geometry and mechanism, or the form, arrangement, and motion of the entities or particles, since we have now spoken of finites, actives, and elementaries. Between all these prevail the greatest similarity both in arrangement and motion; because it is one and the same force which conduces to and creates form, arrangement, and motion, in finites, actives, and elementaries. They may, therefore, in consequence of their agreement in these respects, be geometrically and mechanically described together. With regard to finites, we make the following observations.

1. The particles in a finite or compound are similar to one another, in regard to form, arrangement, and motion ; the individual parts of these again are also similar, and so on up to the first point in which lies the primitive force and first cause of finiting the sequents. It is in similitude that the sequence and connection of things in regard to existence and subsistence consist. In the first motion and form there is no angularity or inequality ; nothing which can by derivation be rendered geometrically or mechanically dissimilar. It is an entity without modes, being most simple and most perfect. Derivatives do not inherit any dissimilitude from this entity

Consequently similitude is produced in its compounds, and again successively into the compounds of these.

2. The arrangement of these similar entities is obtained by motion, and the form both of the motion and arrangement is spiral; hence arises an effort to a similar motion and form ; and afterwards, again, a similar effort as we have above shown from principles both of reason and geometry. Poles also and polar cones are necessarily formed by this spiral form. With regard however to these spires or spiral circles, I observe, that the spires nearest the centre have a greater curvature, and those farther off a less, both in the polar cones and in the surfaces ; also that in the polar cones the kind of spire is different from what it is in the surfaces, whether it is nearer to, or more remote from, the centre. A finite which is an aggregate or assemblage of parts reduced by motion to a certain arrangement does not , consist of one surface, layer, and row extending from the centre to the outermost surface, but it consists of several; for it is a particle whose individual parts are similar to one another; it has a convex form, but at its two opposite ends it has its poles gradually widening from the centre, and hollowed out into the form of two cones. Thus we see, from the geometry of the figure and mechanism of the arrangement, that both in the polar cones and at the surfaces, the spires at the centre have a greater curvature than the spires at the surface. With regard to the spires of the poles' the reader is referred to Fig. 12 (p. 173), where the polar cones are AEB and CED, the spires near the centre, *l, k, i*, have a greater curvature than the spires *h, g, f*, above; a curvature which becomes less and less in proportion to the distance from the centre. The same is the case in the surfaces extending from one pole to the other, till we come to the outermost surface in which the spires are similar to those which are represented in the following figure (13), and which run from *g* to *b* and so on ; in the interior parts however they pass through several gyrations or circles running round the surface, before they come to the

other pole. The cause of this fluxion is mechanical. Let the particles in this figure be conjoined at their poles, and thus connected together into a line or chain ; let the chain thus formed be so gyrated as to cross from one pole in the figure" to another and to produce a surface ; in this case we cannot turn it round without forming spires, running over the surface from one pole to the opposite. In this manner will similar particles turn themselves, when connected as to their poles; they will first pass into spires similar to the polar

Fig. 13.

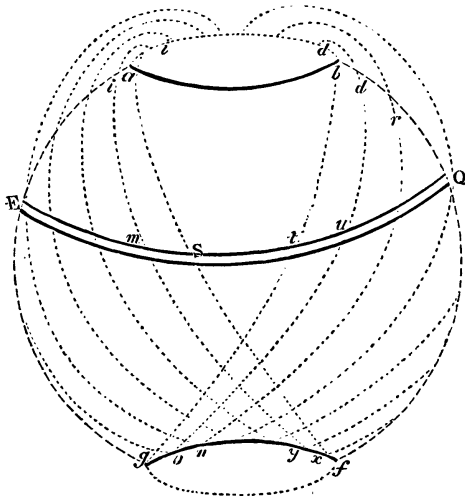

before they can be brought over the surface to the opposite pole ; and thus by a continual relation to their poles, they will advance into a new surface and onward to the ultimate or outermost, where, both in the polar cones and in the surfaces, the spires are of less curvature ; the situation of the parts relatively to their figure and centre being always preserved.

3. A small cavity is left in the middle, which on one side extends farther from the centre than on the other. If we have a spiral as in Fig. 1 (p. 118), where the centre is in *a* and the flexure of the spire in *h*, *i*: it follows that on one side, the distance from the centre is greater than on the other :

st property which is essential to every spiral. If the arrangement of the parts are spiral, then whatever be the manner in which the spires are formed, the distances from the centre are unequal, being greater on one side than on the other. The same is the case in the present instance. If we would turn round the forementioned chain which consists of particles of the same form linked together into the form of a spire, always preserving the connection and arrangement of the parts relatively to the centre, we shall find that there is no way of doing so without making the distance on one side of the centre greater than on the other. From the same mechanism it follows that the plane of the ecliptic cuts all the superficial spirals midway from their centre; so that there is as great a length of spiral on one side reaching to the centre or pole, as there is on the other.

4. The centre of gravity is situated outside the middle and is in the plane of the ecliptic. If the figure is spiral its centre cannot be in the same place in which it would be if it were merely circular; if the cavity in the middle be wider on one side than on the other, the centre of gravity cannot be in the middle. In like manner in no other plane but that of the ecliptic can all the spiral arcs be cut in the middle; this is the plane, consequently, to which all the spires have on every side a concordant relation.

5. Before passing from the form of this finite or its geometry to its motion or mechanism, we will add that in every finite, active, and elementary, there are larger and smaller circles, an equator, ecliptic and meridians, because there are poles as in Fig. 7 (p. 150), where is the equator, which is in the middle between the poles and parallel to the polar circles *ah* and *gx*. The meridians run perpendicularly from it to the poles. The circles of latitude are the same as the spires in the surface (Fig. 7, p. 150), such as *lg*, *aF*, and the others. The bisection of these will give the ecliptic, whose poles are consequently in the polar circle.

There is an axillary motion of the whole particle; it is



most rapid when the particle is most at freedom, less rapid when in a state of compression, and there is none in the highest degree of compression ; as is evident from what has been previously said. In like manner, there is a progressive motion of the parts, *in consequential*, or according to the plane of the ecliptic. The progressive motion is also greatest in the greatest state of freedom, and least or none in a state of compression. Also, from an axillary arises a local motion ; this local motion is determined by the centre of gravity, and is directed by the progressive motion into the form of a surface.

7. With regard to actives, it follows from their mechanism that the local motion by which the surface is described is spiral; that in this apparent surface there are poles ; that it has larger and smaller circles, like finites; and hence that in respect to form, finites and actives are similar to each other. As in figure, p. 191, where *hg, do, iy, ax*, are perpetual spirals, which in their course form the nodes *t, u, S, m*, with the equator, and which are also equal to one another. Moreover, if the motion of the active is spiral, there must be poles. Without poles no surface can be formed by a spiral motion. The dimensions of the circles or polar cones depend upon the geometry of the spires. The other circles necessarily and geometrically follow the spiral figure itself, such as the equators, ecliptic, and meridians, all of which are concomitants of the spiral motion.

8. The elementary particles, in regard to their figure, are similar to the finites and actives, because they consist of finites, or parts of the same kind, character, and form. Their similarity consists in this, that the finites constituting the surface of the elementary particle are disposed into a spiral arrangement and form, and are consequently endowed with poles or polar cones ; as also that by their surface are represented an equator, ecliptic, meridians, and all the other circles. Al<sup>o</sup>, that in the cones there is a different kind of spire from that in the surface; just as in finites and actives.

In elementary particles the centre of gravity is in the surface;

particularly during a state of compression when the surface is, as it were, convoluted into several folds. For if the figure is spiral and similar to the form of the arrangement of the parts in the finites; if several and complex surfaces be formed by compression, then, according to the geometry of the spiral, the centre cannot be in the middle as it would be if the figure were circular, but must be at a distance from the middle. And since, in the present case, there is no distance from the middle except in the surface (for in an active space there is no middle, because no kind of distance or weight), there is thus immediately passed on from the centre to the surface all that is said to have weight. The centre of gravity therefore is in the surface, particularly in a surface composed of several folds and strata; it is also in the plane of its ecliptic.

In every elementary particle consequently there is an axillary motion. For there are the same separate parts in it as in a finite having an axillary motion ; it has the same arrangement ; the same force, if it be in a free state ; and consequently, from the force common to all, there arises a common motion, conformable to the equator, or round the axis. From parity of reason and of causes it follows that in every elementary particle there is a progressive, as also a local motion ; or a force and tendency to a local motion.

The axillary, progressive, and local motion of the elementary particle is the same in its state of expansion as in its state of compression. The elementary particle, when compressed, undergoes this compression not as to the separate parts constituting the surface, but only as to the active space and the multiplication of the surfaces. For interiorly in the space there is nothing that resists, but only that which acts; thus the active space cannot compress the surface. Therefore the elementary particles are almost in the same state of freedom when compressed as when dilated; and consequently the separate parts in the surface are almost equally mobile, and possess the same force in a state of expansion as in a state of compression.

The elementary particle, in a state of expansion, tends into a larger circle; and, in a state of compression, into a smaller. The more an elementary particle is compressed, the more its surface is multiplied, and the greater number of spiral circles and surfaces are there with which the active space is surrounded ; consequently the more does the centre of gravity recede toward the interior. Inasmuch as the centre of gravity directs the local motion, the nearer it is to the centre of the particle, the smaller is the circle into which it directs its course, but the circle is larger if the elementary particle is surrounded with fewer folds and surfaces. The consequence of this is that the elementary particles, upon the slightest action, tend to flow, in their volume, quite spontaneously, into a circle. For if every particle tends to some motion, then do they all, both as to their volumes and as to each separate particle, tend to this motion ; if only a slight cause of motion or of action in their volume be given. Thus they are fully disposed and ready for a vortical motion ; a mode of motion which, for the same reason, they constantly follow. For if the particles nearer to the large active space are in a state of greater compression than the particles which are farther off, then those which are nearer to the space tend to a smaller gyre and circle, and those which are farther off to a larger; as is evident from the rule, already given.

Finities constituting the surface of the elementary particle cannot be connected and conjoined in any other way than at the poles : and in an arrangement perfectly similar as to the centre of gravity of each. For there is a perpetual action exercised upon them by the enclosed actives, or the actives of their own space. These actives exercise their least action upon the convex side of the finites, and their greatest upon the poles, if the poles be turned toward them ; consequently, with regard to the actives, both within and without, they can form an equilibrium by no other arrangement than by the one in which the part least subject to action is opposed to the active space ; this part is the circular, and the lightest, in which

there is no gravitating centre. Therefore by the continual action of the active space they cannot occupy any other situation than such as is suited to the action of this space ; that is to say, the finites must turn their convex side to this space, and consequently become connected together at their poles. Their centres of gravity are in like manner kept in a similar and corresponding position.

9. There is a mechanical, geometrical, and physical necessity both for the arrangement and motion of the parts and their compounds. Entities which are in motion receive their impulse and direction according to the force experienced and to their form ; and by motion are impelled and directed into equilibrium. And if they are set in motion by any force, it must be in a way adapted to their form and force ; that is to say, in accordance with their geometry and mechanism. Into this arrangement, motion, and form, and into no other, can they come, as the result of any contingent cause or physical necessity. Although, however, causes may be necessarily contingent, yet they do not for this reason cease to be contingent. Nor in case there were offered any sufficient reason for the things which are contingent in the world, or in case the connection of things were assigned in regard to their existence and subsistence, as also the connection of their modes, would any absolute necessity be proved; but only a physical necessity, from which subsequently flows a geometrical and mechanical necessity. With regard, therefore, to finites, actives, and elementaries, it may be stated that, from a geometrical and mechanical point of view, they can be formed in such a manner only and in no other. It is necessity which moves and produces form ; it is necessity which moves and produces form in that particular manner; a necessity without which nothing could exist regularly or naturally ; nor could the world subsist or have come into being.

## CHAPTER VII.

### THE ACTIVES OF THE SECOND AND THIRD FINITE.

1. The primitive energy in the point, such as has been explained, cannot but produce derivatives, and in so doing, when the occasion is presented, must raise itself higher and higher, and by its multiplication into itself produce other things similar to itself. That is to say, from the primitive force in the point, which arises from the continual spiral motion from the centre to the circumference and back again, other finites cannot but be produced successively by multiplication into others; so that from the point there must exist others similar to the point; and hence by its multiplication this point must ascend to higher and higher powers ; so that from these points finites derive their existence by an order of succession, or one after another, as also actives one after another; all having a perfectly similar nature, with a difference only in dimensions, such as there is between greater and less. This follows not only from the fact that the primitive force in the point is most highly active and given to motion, most regularly, similarly, and perfectly active ; but it follows geometrically also from the fact, that beyond all others the spiral form is the most perfectly mechanical, without angularity, without inequality, and devoid of every mode which can produce inequality out of it. Now since a form of this kind is presented to us in the point; and since it exists by motion ; it follows that all the force which can ever exist in such a motion and form of motion, will extend itself by derivation in a most perfect and similar manner. For there can be nothing

## *ACTIVES OF THE SECOND*

in the form itself to beget any difference or inequality; nor is there anything in it to diminish the force. By means of this primitive force, therefore, one finite exists from another in successive order; as in like manner do the actives, which are all of a nature similar one to the other, and indeed of the same nature with the point. Everything mobile, therefore, both in the several world-systems and in the whole universe, exists and perpetually subsists in the point.

We have, therefore, this force produced in the first substantial ; and from the first substantial in the second ; a force which is employed not only in finiting itself, but likewise in actuating itself as often as occasion arises.

2. All the finites which arise from any point have a similar power both of finiting and of actuating themselves. Since the primitive force is passed on to the sequents, and is similar in the sequents to that from which the sequents derived it, the sequents may similarly finite themselves; that is to say, may flow into a similar form, and may also actuate themselves ; that is to say, may run out into surfaces.

3. The active of the second finite is the same as the second finite itself put into a free state. The active of the second substantial is no other than the second substantial itself (of which we have treated in chapter IV.) put into a free state, and thus rendered active. For if this substantial exerted no pressure upon anything by contact, but were free from all contact and at its own disposal, then, in consequence of its having a derivative force similar to that existing in the point and the first substantial, it cannot but in a similar manner render itself active and exhibit itself as the same as the active of the first substantial; for the origin of both is similar, and the cause of their origin is similar. Hence, therefore, it follows that the second finite becomes active if there is no contact; and that the internal force of the second finite is determined into motion, and passes into act if there is no pressure.

4. The active of the second finite consists of particles which

are first substantiate; for it is the same with the second finite put into local motion.

5. The active of the second finite may derive its existence \_\_\_\_\_ from the same causes as the active of the first. With regard to the active of the first finite, we have stated above that it exists from the contingency of the first substantiate not being in mutual contact. The same contingent cause may exist for the origin of these actives of the second finite. The existence of actives supposes a space into which they may project themselves. This being given, the finites immediately actuate themselves; and evidently divest themselves of the nature of the passive.

6. The active of the second finite possesses the same qualities as the active of the first. Since all the actives are perfectly similar to one another, and owe their origin to the primitive force in the point to which they are consequently made perfectly similar, one active will possess the same properties and forces as another. From the same and a similar cause proceeds the same and a similar effect. The active, therefore, of the second finite runs into surfaces of the same kind as the active of the first. This active acts upon the finites it meets in the same manner as the active of the first; it possesses a momentum proportioned to its velocity and weight, in the same manner as the active of the first, not to mention other similarities which it is needless to recite.

7. The only difference between the two is that the active of the second finite describes larger circles than the active of the first; and that it does not move with so great a velocity in its peripheries. The circumstance of its describing larger circles follows from the ratio between its dimension and the dimension of the first active from which it existed. The dimension of the second active is larger: the distance of the centre of gravity from the centre of figure is greater : the velocity of the centre of gravity is less; it therefore passes out into larger circles and moves more slowly than

the first substantial. These results follow mechanically from the difference in the dimensions.

8. The active of the second finite can be in the same space with the active of the first, provided the space be not too confined ; but the actives of the first and second can more easily meet and encounter one another than pure actives of only one kind. As we have said above, the difference between the two kinds of actives consists in one describing larger circles than the other; in one moving more slowly than the other; and one being larger and heavier than the other. These differences, which are differences only of degrees and times, may cause one to encounter another. For if all the actives were of one kind they could not easily meet one another; because the velocity of all is the same; all would describe the same surfaces; and hence, in consequence of the equality of the motion and of the surfaces, no impact could take place ; but a thousand might circulate in one space without collision or impact. If, however, there are other actives that enter into this number and space, differing from the former both as to their circles and motion, then may the one easily come into contact with the other; the swifter may come upon, overtake, or precede the slower; or may within a shorter time come to the same point to which the slower is moving. This it will do also the more easily, since the two differ as to the circles they describe; for the circle described by the slower crosses several of the circles described by the swifter, and cuts it, as it were, in different ways; consequently it presents itself in many places, and very frequently to the swifter, to be overtaken, struck, and encountered. If, therefore, the difference between the circles and velocities is great, one cannot easily flow among the others; still, although they become disturbed by encounters and collisions, they nevertheless can flow one among another in the same space, and all aim to settle into some equilibrium.



9. With regard to its mass the active of the second finite is stronger than the active of the first; but in regard to its velocity, it is weaker. Nevertheless the active of the second finite exercises a stronger impetus than the active of the first. It is well known that active force and weight depend upon the quantity of motion which is the product of the mass and the velocity; and that the momentum is the same when the velocities and the masses are inversely proportional to one another. If, therefore, the active of the first finite moves more quickly than the active of the second, but the active of the second is larger in mass, the quantity of motion in each may be equal; and one may not, therefore, be compelled to give way to the other; for the mass of one may be as much greater as is the velocity of the other. But because the difference in dimension and mass is greater than the difference in velocity, the smaller and swifter will yield to the larger and slower; as may be geometrically demonstrated. This, however, will take place only when the particles encounter each other. If, however, the smaller and swifter collides with one which is larger and slower, the larger is in some measure driven upward by the smaller, or else from one place to another; similarly if it impinges upon it; although the motion of the smaller, at the moment of impact, is retarded. Now since these actives move in a space which does not consist of particles in contact, but in a vacuum where there is nothing to retard the motion, so also there is nothing in it to prevent one body from acting upon another with all its force and in perfect freedom. If in such a void, a smaller active acts upon a larger, and contrariwise, the action itself becomes immediately and instantaneously sensible in each; because there is nothing but the pure mass, or the parts which are in the mass, that offers any resistance in the space, or which tends to prevent each body from being influenced by the active force. They do not move in any medium; hence the action of one upon the other is instantaneously sensible,

in proportion as the parts, of which the active consists, allow of its existence.

10. Actives of the same kind always flow with one and the same velocity ; and they cannot flow with a less or a greater. Consequently, between actives of the same kind there are no degrees of velocity, but there are degrees of velocity between two different kinds of actives. The actives are now in their most perfectly free and natural state so that they can flow with all their motor force; there is nothing to restrain or hinder them; hence they move with all their force, having no more with which to move. And since their free state is nowhere restricted, they cannot move with a less degree of force; therefore they always possess the same velocity. Since the velocities of the actives of one kind are equal one to another, there cannot be any degrees between their velocities, but only between their own velocity and that of an active of another kind which moves more slowly.

11. Actives of one kind always describe the same circles and gyrations, and cannot describe greater or smaller. This follows for the reason just mentioned.

12. These actives do not form their circles or surfaces round one centre, but round several; that is to say, these derived actives run out into surfaces or circles eccentric and not concentric. For since the individual parts of which the finite or active consists, and also the separate portions of which the particles are composed, endeavour to run out into spiral circles and surfaces; there is consequently a tendency of the smallest particles to run into their circles, and of the next smallest or those compounded of the former to run into theirs. These tendencies and forces, operating together, cause the circles or surfaces which are described not to be concentric but perpetually eccentric. The larger the number of composites of which any finite or active consists, the greater is the degree of the eccentricity of the surfaces which it appears to describe, and the greater their frequency. The most simple active, however, such

as the active of the point, can describe only concentric circles.

13. By means of this eccentricity the- apparent surface of the active seems to describe a new and different surface, yet one proper to the active. For if the active produces apparent surfaces, and at the same time moves its centre onward, the surface itself must also seem to move forward in the direction in which the centre moves ; it thus appears to describe a certain circle; therefore it would seem as if the active consisted of three dimensions, and as if it had a breadth equal to the diameter of its first surface.

Hence it follows that, by the progression of their centre, actives are transferred into every imaginable point of their space, and move from one extremity to another ; also that one active may represent a space most perfectly full, as much so indeed as if it were occupied by a legion. For since by its continual eccentricity the surface is carried from one place to another, and into some larger circle, it is hence superficially moved to every point in its space; and thus seems to be able, as it were, to push on with many figures and forces to any point round about.

14. Actives cannot be said to form anything contiguous or to occupy any determinate place. Place itself is the relation of one contiguous thing to another. Place or locality obtains only in things contiguous. In the present case, however, the surfaces are only imaginary, apparent, and figured out by motion. There is only one real point in the whole surface which can touch the surface of another. Hence there can be no contact of surfaces ; consequently nothing contiguous ; and, for this reason, no place, unless the actives were so enclosed in one space as to have their boundaries in those which enclose the space ; otherwise they could have no space; for the space is measured by the boundaries, not by the enclosed actives; so that space is a distance from one boundary to another ; although interiorly there can be no distance from one active to another, or from the surface and centre of one

to the surface and' centre of another. Thus the diameter of the space cannot be divided into smaller degrees or distances, except relatively to contiguous particles which are out of the space; that is to say, except in an imaginary manner.

15. Actives are devoid of all determinate place and arrangement, unless they are enclosed by finites or elementaries. Unless the space consisting of actives were bounded by some surface consisting of finites or elementaries, the actives could not be enclosed, and thus could not form a space. For by reason of their eccentricity they run out into all space ; nor do they ever return to it without completing a second, third, or fourth circle, according as their circulation is either of a fewer or of a greater number of dimensions. And since they are thus nowhere enclosed, neither can they naturally be, as it were, transferred into any place, and at the same time into some different motion, except by means of a surface consisting of finites.

Actives have nowhere, in their enclosed space, the relations of upward or downward. Upward or downward or directions to any particular quarter result solely from contiguous elementaries, and from the motion and arrangement of the particles in contact. In the present case there is no medium, much less any contiguous medium ; nor any disposition of a contiguous medium by motion. Therefore in the space of these actives, as also in the peripheries which they configure, they cannot be said anywhere to tend either upward or downward. But wherever they are in their peripheries, there also they are in their position of above, below, and sidewise, all at the same time; to them the perpendicular, horizontal, and oblique are all one: these peripheric boundaries are clearly unknown in the active space, and are there confounded one with the other; consequently in this active space neither is there any weight. The largest active space has the same weight as the smallest.

16. Actives cannot be said to resist but only to act. Since they form nothing contiguous, they do not resist but

only act; resistance belongs only to what is contiguous. Also since actives flow in no medium, they are displaced by the slightest encountering force, and sent out of their own surface into another ; nor is there anything in them which'----- can offer the least impediment, except their mere velocity and weight. Since, therefore, they act merely by form, velocity and mass, they cannot be said to resist.

17. No number of actives constitutes an element or matter ; nor are the actives themselves to be considered as elementary particles. Since they form nothing contiguous, so that they can be moved together and pass contiguously into a similar motion ; and since they cannot produce motion in any volume, or occupy or fill any place, or do other things which are essential to an element, they cannot possibly be considered as elementaries. In their figures there is almost nothing real, there is only what is formal; hence they cannot be called material.

18. The force of the active space is increased, and becomes the stronger according to the number of actives. If there are many actives in one space, there are many entities which act, or many active forces; and if anything comes in their way, not only do a great many actives act upon it, but upon all its parts, at every angle ; and turn and move it in any and every direction. Thus the more actives there are, the more multiplied and consequently the stronger is their action upon anything that comes in their way.

19. A space filled with actives of the first and second finite, acts more strongly than if filled with actives only of one kind. The active of the first finite acts by its velocity upon what it meets ; upon a smaller composite, but one similar to its own. The active of the second finite, however, acts both by its velocity and weight; so that it possesses a greater momentum, and can thus act upon a larger composite or one consisting of more parts. Since, therefore, each acts by velocity, and one also by its weight more than another as also by a larger form than another, it follows that both kinds of actives together

## 206 *ACTIVES OF THE SECOND AND THIRD FINITE.*

can act more strongly than only one kind. For there are composites of finites which require to be acted on both by velocity and weight ; and which can be moved only by the actives which are heavier in weight.

20. The solar ocean seems to consist of the actives of the first and second finite. For it is these actives that are the causes and origins of all the ulterior changes and compositions which occur in our nascent world, and by which alone the first and second elementary particles can be produced. Unless there were some large space filled with actives, their sequents could not be produced. As yet, however, no other actives are afforded than those of the first and second finite ; it follows, therefore, that it is of these that the solar ocean originally consisted, and continues to consist even to the present day.

### **ACTIVES OF THE THIRD FINITE.**

1. The primitive force in a point continually produces similitudes of itself, by the multiplication of itself into itself, whenever occasion offers and the force can go out into act. It has been above shown, that by the mechanism of its motion and perfectly regular and geometrical figure, the primitive force in a point cannot but produce similitudes of itself, and continue to produce them in their sequents : consequently, that a substantial thus arising cannot but be perfectly similar to the point, and possess a perfectly similar power of producing sequents in like manner. There may, therefore, be substantials which by their multiplication into themselves, and thus by being frequently compounded, are elevated into higher powers. So that if the first point were considered as one, and 100 points constituted one smallest substantial, the second substantial would consist of 100 first substantials, or of 10,000 points; the third finite would consist of 1,000,000 points; the fourth finite or substantial, of 100,000,000 points; the

fifth, of 10,000,000,000 points; and so on by a continual multiplication of the substantiate into themselves. And since the actives are the same with the finites or substantiate in a free state, it follows that one active must consist of the same number of points. Hence the third active consists of 1,000,000 points, or 10,000 first substantiate ; and so on. This number I have fixed upon only by way of example ; for we cannot tell what may be the number which at first has to be multiplied into itself.

2. The active of the third finite is the same as the third finite itself in a free state. Of the third finite we shall soon treat in the sequel; as also of the manner in which it arose from the compression of the elementary particles, and was thus made similar to the second finite, the first, and the point.

3. From the same causes also it follows that the third finite is rendered active, if there is no contact with similar finites ; just as is the case with the preceding finites.

4. The velocity of the third active is less than the velocity of the second, and still less than the velocity of the first. This is evident from what we have already stated in our theory of the active.

In the same manner also the circles and surfaces which the active of the third finite describes are larger than the surfaces or circles of the active of the second ; and still larger than the circles or surfaces of the active of the first.

Moreover the mass in the substantial of the third active is greater than the mass of the substantial of the second active; for it is composed of second finites ; and thus it is larger than the active of the second by a hundred times or more.

5. The active of the third finite acts both by its mass and velocity; and it is more powerful in its action than the active of the second. For since the quantity of this motion is greater than that which is in the active of the second, it follows that the active of the third acts by both, namely, the mass and

velocity, more strongly than the active of the second. For the greater velocity in the active of the second cannot be in the same proportion as that of the larger mass in the active of the third. Consequently if the velocity of the active of the third is multiplied into its mass, and the velocity of the active of the second into its mass, there results a less product or a smaller quantity of motion in the active of the second finite than in the active of the third. With regard to weight, it does not appear that we can speak of it as predicable of the third finite ; but instead of it we substitute mass ; for there is no medium in which the finite flows, and consequently no weight can be perceptible. Inasmuch, however, as it consists of larger individual parts than the active of the second finite, and consequently of a larger mass, it follows that if it experiences impact in any manner, the mass with all its individual parts is immediately sensible of the impetus; and before this sensibility reaches all the individual parts, the mass shows itself incapable of being moved. In relation, therefore, to the communication of momentum to its individual parts, something which is similar to weight and resistance is presented to us.

6. The active of the third and second finite may be simultaneously in one space. This follows from the reason above mentioned, namely, that the active of the second and first finite may move simultaneously in one and the same space. In consequence of the difference between the velocities and the circles, various impacts and collisions originate, and although these may happen to actives of both kinds, yet these actives are not for this reason driven out of their space,, but may after collision perform their rotations as before.

\*7. The actives of the third and first finite cannot be simultaneously in one and the same space ; since in consequence of the difference between their velocities, circles, and dimensions^ the circles and motions of the first active would be thrown into utter confusion, and either these would be expelled thence or els& the active would become absorbed. Their inability to move in



one space arises from the difference between them as to velocity, form, and dimension. The velocity of the third active is much less than the velocity of the first; hence not only does the active of the first constantly meet it, but also collides with and impinges upon it every moment. For since they differ in the circles they describe, the active of the third finite forming larger circles than the active of the first, and consequently crossing over numerous surfaces of the active of the first, it must necessarily happen that they are almost everywhere in collision. Inasmuch also as they differ in dimension and mass, so much so indeed that the active of the third finite is nearly 10,000 times larger than the active of the first, it follows that the impetus of the first active, as exercised upon the active of the third, is but small; and that the active of the first may be impelled and driven about by the active of the third in every direction. Now since this conflict is perpetual, the actives which possess a smaller degree of force and momentum are compelled to abandon their place, and are driven away in another direction. If, moreover, we contemplate the structure of the active or of the third finite, we see it consisting of particles which are second finites or substantial; and consequently the spaces between the particles are so large that the active of the first finite can flow into them, and become entirely secreted in them; and as the collisions are so frequent, the actives of the first finite may possibly flow into the spaces themselves, and they thus become absorbed and entirely disappear. Consequently there cannot remain in one space actives which are very different from one another in dimension, velocity, and in the circles they describe.

8. By means of the influx of the actives of the first finite, the actives of the third may ultimately lose their active force. Since in the active of the third finite the spaces are so large and so widely open that the active of the first may flow into them and bury itself, so by their continual-influx these spaces may be filled, and the motion of its particles be

more and more impeded ; till at length, by the multiplication of these entities, it may be entirely destroyed. For a perfectly regular motion cannot be preserved except by and among particles precisely alike ; this motion, by the intervention of such as are dissimilar, is impeded, and, as it were, under restraint, and consequently becomes irregular. Now with the destruction of this regularity all its active force is destroyed ; a force which consists only in motion and in the regularity of motion.

9. There are in the world no actives of the third finite ; but they are all third finites, and compose the surface of the second elementary particles. For since they cannot move in the same space with the actives of the first finite, and since the large active space or solar ocean consists, according to our hypothesis, only of the actives of the first and second finite, and since the three cannot be simultaneously in the same space ; it follows that in this large space there are no actives of the third finite, nor are there any in the elementary particles of which we shall speak in the sequel; hence they must remain passives and finites, and occupy the surfaces of the elementary particles ; hence also they contribute to the composition of new elementaries, and perform their functions in the surfaces of these particles.

## CHAPTER VIII.

### THE THIRD FINITE OR SUBSTANTIAL.

BEFORE the world with all its elements and parts was formed and brought to the perfection and beauty in which w'e now behold it, it was requisite not only that it should undergo a vast variety of changes, but that its parts should be multiplied one into the other in every variety of manner. For the world could not consist or be formed and perfected from a simple and single element, nor from a simple and single active, nor from one or two substantiate ; for in this case it would be perfectly simple and pregnant only with first principles; by means of which, without changes and multiplication, no ether, fire, air, nor anything else could ever come to our knowledge. For had the world remained in a state of first principles and perfect simples, it could not possibly present to us such a variety of phenomena as it does ; nature could not have acquired such various methods of unfolding her forces, and of representing herself to our senses with an aspect so joyously and delightfully varied by appearances, or by other means derived *a posteriori*. Nature would have been in possession of a vast empire destitute either of inhabitants or subjects, in a word, she would, as it were, have reigned alone in her own vast empty courts. She would behold no kingdoms in subjection to her to which she might give laws; no elementary, and much less, any mineral, vegetable, and animal kingdom.- For the visible world is a series of finite things both simultaneous and successive ; modified and connected with one other in a multiplicity of ways, and in a long extended order. Every kingdom of the world postulates

a nature much multiplied together, derived from and augmented by her forces. Hence nature could not stay her course and rest in those principles we have hitherto been explaining, but must progress still farther by increased multiplications, derivations, and dimensions of her parts and their compounds ; so that the more numerous the classes of finites, actives, and elementaries successively arising by multiplication, the more enriched, beautiful, and perfect is the world.

1. Consequently, the third finite or substantial is that which, as to its origin, parts, figure of parts, arrangement, motion, and so forth, is perfectly similar to its preceding substantials or finites, or to the second finites, the first, and the point. For not only are all the finites perfectly similar to one another, but also all the actives and elementaries. Nay, even their composites, or entities multiplied one into the other, or derived from their individual components, do not differ from one another in regard to form, arrangement, or motion : but only in dimension, paths, movements, and degrees.

2. Therefore the third finite consists purely of second finites; or, the corpuscles, or parts of the third finite are purely second finites ; the separate parts of these corpuscles again are first finites ; the separate parts of these again are simples, of which we have spoken in chapter II. Consequently this third finite is no other than a simple or point multiplied thrice into itself or raised to its third power.

3. Since this finite is similar to its antecedent finites, and is a third generation from the points, it is of the same quality with its antecedent finites. The separate parts of this finite are consequently connected as to their poles, and are disposed into a spiral order, arrangement, and curvature. The compound has thus a figure perfectly similar to that of its component parts ; the poles and polar cones have the same figure; as also the larger and lesser circles on the surface. Hence arise a force and effort tending to an axillary, progressive, and local motion. Thus also does the compound follow its preceding finite in possessing the same power of being passive and active, and of

being similar to the former in its state of inertia, and partly so in its state of activity ; and of producing a new finite, active and elementary. Thus this finite is the same as the finites already mentioned ; but of greater size.

4. This finite derived its origin from the first elementary particle in its state of highest compression, and near the large active or solar space. All the second substantiate, which are its separate parts, are now not collected into one whole, but form a surface and expanse of particles ; they are passives, but constitute, together with their enclosed actives, a new class of particles ; that is, of elementaries such as we have already explained. This finite, therefore, derives its origin from the elementary particle; for it is the same as the elementary particle in its most highly compressed state, in which the actives have vanished in consequence of the compression. Let us revert to the theory of the elementary particle. We have said that these particles may be expanded and compressed ; that under a state of compression they become very similar to finites ; that they ultimately cease to be elementary ; and that actives, when banished from their localities or reduced within a narrow compass, become finites or substantiate. With regard to the way in which this is done we have said, that by means of compression the elementary particles retreat into a less space, and, as it were, into themselves; that their surface becomes multiplied three or more times, and ultimately into as many series and orders as there are spiral surfaces in the finite ; that in their highest state of compression they more and more divest themselves of their elementary nature, and become more and more like a finite ; until the whole of their elementary nature becomes changed into that of a finite, their elastic into a hard nature, and their highly compressible into a stubborn resisting nature. Now this can occur in no other place than round the large active space, in its vortex. Imagine this active space, or the sun, surrounded with a large volume of elementary particles, and its action upon the volume or surrounding particles to be continuous ; imagine also a certain

vortex to be in a state of formation but as yet not formed. In consequence of an action so immense, it is not possible but that the nearest elementary particles will be most violently urged, moved, and impelled to action, as also all the others next to them for some distance around. Those which are nearest to the sun are in the first and greatest degree of action ; the others, in proportion as they are farther removed, are in a less degree ; consequently they are in a greater or in a less degree of compression according to their distance. For since a vortex is not yet formed, but is only in a state of formation, there is an effort against and disobedience to one and the same general motion. For all the particles are in the same degree of expansion ; all, upon any given action, strive toward the same circle and gyration. One, therefore, tends to press and impel another to the performance of the same circle with its own; each urges the adjacent one ; and thus the action extends to a considerable distance from the sun, till all, by its continued existence, are reduced by motion and compression to their natural state. Thus the particles which are nearer the sun and more compressed, tend to a smaller gyration than those which are farther off and less compressed. In this situation and state of compression, proportioned to the several distances from the sun, they finally flow naturally with unimpeded current, with unanimous consent, and of their own accord, the force inherent in every particle directing the motion ; and the solar active space, by its action, maintaining the particles at every distance from it always in a similar and proportionate state and degree. Before, therefore, the vortex is so formed that the particles, according to their distances from the sun and their degrees of compression, flow by a spontaneous effort into a general vortical motion, it must necessarily happen that those which are nearest to the large active space retire into smaller and smaller dimensions ; and are so compressed as to be deprived of all their elementary quality, and to become entirely third finites.

5. From these third finites there may arise again new elementary particles. For these particles are similar to the antecedent finites which constitute the surface of the elementaries. They begin near the large solar space where are the actives both of the first and second finite ; and they can act with a greater force on the finites of higher power or larger dimensions. They have the same place of origin, and a similar cause ; hence they are expanded and elevated, like the second finites, into new and similar elementary particles. Of this, however, we shall speak in the following chapter.

## CHAPTER IX.

THE SECOND OR MAGNETIC ELEMENT OF THE WORLD ; THAT IS, THE NEXT ELEMENTARY PARTICLE COMPOSED OF THIRD FINITES AND OF THE ACTIVES OF THE SECOND AND FIRST FINITE. ITS MOTION, FORM, ATTRIBUTES, AND MODES. THIS ELEMENT, TOGETHER WITH THE FORMER, CONSTITUTES THE SOLAR VORTEX, AND IS THE ONE WHICH PRINCIPALLY CONTRIBUTES TO THE PHENOMENA OF THE MAGNET.

Another and new element comes now into our simply solar world. Unless there were elements crowding round the sun, there would be nothing upon which it could act, and through which it could extend its sway into the remotest and most widely scattered regions. Without elements the active space would be a centre without circumferences ; an active without passives ; a soul without a body ; a space without place ; an eye with no quarter toward which to look ; there would be no upwards, downwards, or sideways ; in a word, without a termination in elementaries nothing would exist; but everything would relapse into its original emptiness. For this reason the solar ocean is surrounded with new elements, and with their help Titan extends the rays of his empire and his arms and sceptre into the remotest regions of the universe. The quality, however, of this new element and the parts of which it must consist, result from their connection with its first principles, and from the same mechanical and geometrical necessity as pertains to the others that we have been considering.

1. The second elementary particle consists of third finites, and



of the actives of the second and first finite; that also the fore-mentioned finites occupy the surface, and the actives the internal space. The third finites which had entered into the world, and of which we have spoken in our former chapter? were near the sun or the large active space of the vortex ; consequently they cannot remain finites, because they are near the active space, but must necessarily be convoluted and aggregated into new surfaces, in the same manner as are the second finites into first elementary particles. For according to our hypothesis, the first elementary particles next the sun are most highly compressed; and, in consequence of the compression, cease to be elementary, and exist as finites of the third kind ; and since they are thus near to the sun, it follows that they are put into operation by its actives, and are in like manner convoluted into new and elementary surfaces ; these surfaces being occupied by finites, and their internal space by the actives of the sun ; just as water is carried by the ether into vapour; and other liquids, when placed over the fire, are converted into bubbles.

2. The second elementary particles, both as to their origin, form, surface, and space, are perfectly similar to the first elementary : they differ only in dimension ; for the second elementary particles are larger in space and surface, since they consist of larger finites and actives. With regard to their origin, these second elementary particles originate near the solar ocean or large active space ; namely, where the actives of the second and first finite are, or where the actives can operate and act immediately upon the finites, to reduce them into subordination, and not to cease before they come into a state of equilibrium ; the finites constituting the surface, and the actives occupying the space within. In this manner it is that the first elementary particles arose, as we have previously described ; and hence we find a similarity between the two in regard to their origin and existence. The second elementary particles are also perfectly similar with regard to form ; for if in both elementaries the finites constituting the

surface are similar, as also the actives occupying the internal space, there must result a perfect similarity in form, and an equilibrium between the two. They must, therefore, be perfectly similar in regard also to surface and space. The only difference between them is one which is common to all the products of nature, whether finites, actives, or elementaries ; namely, that the second or derivative are larger in dimension than the first.

3. The second elementary particles possess the same elasticity as the first. From a similar cause arises a similar effect. If the finites occupying the surface, the actives occupying the space, and the forms, are similar ; then there must be also the same susceptibility to pressure, and the same elasticity. For in this case likewise the surface lies expanded between two forces, and in a situation perfectly natural to it. Interiorly are the actives, which only act but do not resist; although, by acting not only upon one but upon all the parts, they resist, as it were, or react. Hence also it follows that the reaction of the surface is equal to the pressure; that it recoils and reacts with the same force with which it is pressed ; that the sum of the force before and after the conflict is the same, or that the same quantity of forces is preserved in every collision and compression ; that the surface, when liberated from the compressing force, is immediately restored ; that the effect of its weight is inconsiderable, so that it cannot be said to lose anything on that account; and that in the expanded particle we must imagine the momentum to be as small as possible, or as nothing ; that in this particle there may be all the degrees or kinds of elasticity; but this only according to the degree of compression. Not to mention other predicates of the first elementary particle, with respect to susceptibility to pressure, and elasticity.

4. The second elementary particles may be compressed and expanded in the same manner as the first. Their centre of gravity is in some part of the surface, and when in a state of compression is nearer the interiors than in a state of expansion. Similarly these elementary particles have an axillary motion, and

collectively a tendency to a local motion. The particles which are nearer the sun and are in a greater degree of compression, tend to a lesser gyration and circle; and those which are farther from the sun or in a less degree of compression, tend to a greater. In virtue of the effort exercised by each, and a certain degree of accessory force from the active and central space, they spontaneously conspire to the vortical motion most adapted to them ; a motion which, by reason of the action of the sun and the force and effort inherent in each particle, they always preserve: not to mention other particulars which we have already stated of the first elementaries. For if the centre of gravity be in the surface of the elementary particle; and if, by reason of the effort made by the finites constituting the surface, it be continually rotated round the axis, it follows that, from the common effort of all these, there exists an effort of the elementary particle or compound to a certain rotating motion. Since the centre of gravity recedes in a compressed particle more towards the interiors, and the axillary rotation is swifter, the particles, when compressed, tend to a smaller gyration than when expanded ; and if their degrees of compression are according to their distances from the sun, there is a general consent and effort of all to the same vortical gyration ; into which they are also perpetually sent by the vortical motion.

5. The surface of the second elementary particle is exactly balanced between two forces; interiorly it is pressed by its active, and exteriorly by the first elementary. No surface could subsist without an equilibrium produced by the forces on both sides ; there must be as great a degree of action on the convexity of the surface, as on its concavity. \* Exteriorly are the first elementary particles, possessing the highest mobility and elasticity ; exercising a pressure in proportion to their altitude, and being capable of acting on the convex surface, as also on the convex part of the polar cones; interiorly are the actives of the first and second finite, acting. Therefore the surface is naturally balanced between the two forces, tending neither

inwardly nor outwardly, but lying suspended between them, and exposed to every supervening external motion, the similitude of the figure being preserved in every case, and under every state of compression.

The first and second elementary particles may concordantly flow in one volume, sphere, and vortex. Although they differ in size, and although the second are larger than the first, nevertheless, since they are perfectly similar in form, elasticity, axillary motion, and effort towards local motion, there is nothing to prevent them simultaneously flowing in the same volume, and by a simultaneous motion forming the same gyre and vortex.

6. These second elementary particles are similarly subject to the pressure of others resting upon them; and the pressure of the incumbent particles is proportioned to their altitude in the plane of the zodiac, and also to the area subjected to the pressure, provided their volume be reduced by motion to a regular and vortical arrangement. This follows from the reasons which have been alleged in the theory of the first elementary.

7. The third finites constituting the surface of this elementary particle unite and become passive, in a manner similar to that of the second finites in the surface of the first elementary particle. If there is a similar figure and arrangement of the parts, there will be a similar conjunction and connection of parts ; if the form is spiral, if there are poles or polar cones, and if there are spires traversing the surface obliquely and extending from one pole to the other after the manner of a helix, it will follow that the conjunction of all will be so reciprocal and close that one cannot be moved without the other; that a change of state in one implies a change of state in the other ; that if one has an axillary motion so must the other ; not to mention other particulars which we have stated in our theory of the finites or surfaces belonging to the first elementary particles.

8. The finites constituting the surface, like the finites of the first elementary, turn their convex and lighter part toward their internal space; and they are thus compelled to cohere as to their

poles. The enclosed actives are themselves of the same nature and character, because they always act upon the concave surface; and wherever they meet with anything angular or unequal, they assail, turn about, and disturb it until that part is opposed to them upon which they cannot act. The convex part of the finites is that upon which the least action can be exercised. This, however, is not the case with the part where the poles are. There is, therefore, a certain mechanical necessity that the finites should be connected, as to their poles, in the superficial expanse of the elementaries. Nor can their sides be conjoined in any other manner, since their active space prevents them from taking up any other position.

9. The motion and essentials of the volume are similar to the motion and essentials of the parts in all the elements, and reciprocally. For all the elementary particles are moveable of themselves; and, since they are elastic and very susceptible to pressure, there cannot be any motion of the volume or any common motion without a motion of each particular part. There cannot be motion in the volume, without the concurrence of the particle in the motion ; *so* that the motion of every part contributes to the general motion. It follows, therefore, that the whole motion of the volume is in most perfect accord with the motion of each part; that the form of the motion of the volume is exactly similar to the form of the motion of each part; and that the elasticity of the volume is exactly similar to that of the parts composing it. Thus from the modification of the whole or of the volume, the nature of the figure and motion in each part may be concluded. Such is the characteristic which distinguishes the elements. Nothing can occur in the volume and its compound which is not perceived individually in each particle ; nor is anything perceived in any individual particle which is not rendered sensible in the volume at a distance. The contrary is the case in things hard and substantial, the parts of which cannot be moved separately, but must all be moved simultaneously

with the compound. Hence from the phenomena which occur in elementaries we may easily draw our conclusion with regard to the essentials of every corpuscle and part; and from the parts again we may draw our conclusions with respect to the volume.

10. The second elementary particles may be compressed into their smallest compass, in the same manner and by the same cause as the first elementary particles. In their highest degree of compression or nearest the large active solar space, they change into new finites, which may be called the fourth finites, and are similar to the preceding. That they are susceptible of compression is beyond a doubt; inasmuch as they are compressible, elastic, and similar to their first elementaries. Those also which are nearest the large active solar space are in a higher degree of compression than the more distant; and these degrees of compression are in the ratio of the distances, or as the vortical circles round their centre, since their forces and efforts tending to their circle or gyration are according to the distances, and consequently according to the modes of compression.

Let us, therefore, again conceive a solar vortex as yet not formed, but in a state of formation, having an incipient vortical motion, but not yet habituated and wholly given to it. In this state the elementary particles are not yet compressed according to their distance; nor are their efforts and forces in the same ratio, namely, that of their circles which they describe. Hence we must conclude that in this state of incipency and formation of the vortex, the particles next to the solar space would be exposed to the greater and more immediate action, while the others would be acted upon in the ratio of their distances. The particles, therefore, which are next to the solar space are in the highest degree of compression, and can be reduced into the smallest compass, or into pure finites. After the vortex is formed, however, and every particle is compressed in the ratio of its distance it does not appear to be mechanically possible for any compression

to be carried on so as to produce an ultimate, or smallest particle or finite. That when the vortex is formed these second elementary particles will have receded to a distance from the solar active space, we shall have to show in the course of our future observations.

11. In every particle of this elementary kind there is everything in the world which has hitherto arisen from the point; and every elementary particle is a least compendium of the preceding world and its entities ; there is thus a most perfect harmony between the parts and the compounds, and the closest connection of all with the first. All the pre-existent finites and actives concur in composing this elementary particle. The point itself is the simple of all the finites, actives, and elementaries, and consequently it has entered into the substance of each. The second finites are the parts and separate portions of the substantials following, or the second and third. The third finites, therefore, occupy the surface; in these are\* the second and first finites, and the simples. Within the surface are two kinds of actives, namely, those of the first finite and of the second. The first elementary particle itself, compressed as to its surface to the utmost and into the third finite, composes this elementary particle as a finite. Hitherto, however, it flows extraneously as an elementary particle, and keeps the surface of the first elementary particle expanded and in equilibrium with actives reacting. Thus in every part of the world, a world is latent; in the microcosm lies the macrocosm ; what is in the greatest is latent in the least; what is in the whole vortex is in its smallest part, with all the substantials, essentials, and modes. The motion of our large system is latent in a least system ; so also is the figure ; whence in largest as in least things, the world is similar to itself. Its least part is a type of its greatest; its greatest is an image and similitude of its least. It is for these reasons that the world is maintained as a unity in virtue of a perfect harmony between the parts and the compounds.

## CHAPTER X.

### THE EXISTENCE OF THE SUN AND THE FORMATION OF THE SOLAR VORTEX.

No longer dwelling merely upon parts and particles, I shall now proceed to compounds, large spaces, systems, and the world itself; from the goal we shall go into the open plain ; and, from the principles already laid down, contemplate the existence of the sun and the vortex forming round it; both of which are yet in a state of infantile existence. As, however, we now come to treat purely of contingencies, causes must be partly conjectured, and partly derived from the connection existing between our principles. That no portion of our subject however may be left untouched, but that our system may follow the principles laid down, and observe an unbroken series and orderly sequence, we shall now add a few words on the existence of the large solar space and its vortex.

1. According to the tenor of the foregoing principles, it appears that the large active solar space could primitively have consisted only of the actives of the first finite. That the solar ocean existing in the middle of its vortex is the fountain of all the motions which take place between the parts constituent of its world, is, I imagine, perfectly clear ; as also that it is, as it were, the soul of its immense body and system, and a perfectly active centre, around which the smaller and larger parts are whirled in a perpetual current. If, therefore, there is a largest and most active space, then, according to our principles, it could primitively consist of no other than the actives of the first finite ; for it is necessary that, in coming forth into a world, the actives should proceed successively and by



gradations of time, without which the chief principle of truly natural entities would be wanting ; and the world could not be perfected. Hence, if there is a perfectly active solar space, consisting solely of actives, it cannot consist of any other than the actives of the first finite.

2. No space or place can be occupied or enclosed by actives, unless it is surrounded by finites, in which alone it can be terminated and limited ; and consequently in respect of which it can be called a space. Actives of themselves enclose no space, except in relation to the surrounding finites. Space and place are relative to what is contiguous. They can exist only in a contiguous expanse from one particle to another, as from one limit to another ; for a space is always limited, formed, and terminated, in real entities. Actives, however, form nothing contiguous either from one centre to another or from one surface to another; consequently no degrees or momenta can be reckoned among actives ; nor can any fixed limits be established. They are only the ideas, conceptions, and similitudes, of forms and surfaces; they are particles only in appearance ; these describe not one but an infinite number of centres, and an imaginary surface not in the same but in an infinite number of places. Hence of themselves they enclose nothing, and limit nothing; but are themselves to be enclosed and limited. We can, therefore, conceive of no solar space without surrounding finites or elementaries. If therefore there is a solar space, and in its middle the most perfect activity, then, according to our principles, it could not, in this primordial state of things, be surrounded with any other than the finites of the first active, compressed all around into a narrow compass by the action of the space.

3. By the powerful action of this space the surrounding finites can be reduced into such an arrangement, that one may be in contact with another ; and consequently be able to finite themselves; and by means of motion one among another to flow into second finites. This also follows from what we have said. For if the forementioned finites limit the space,

and confine the actives within given barriers ; they must necessarily become reduced to such an arrangement as to have their sides mutually joined by contact, and to so closely touch one another, as, according to our theory of finites, mechanically to finite themselves ; and, by forming a new compound, to multiply themselves. Hence we derive the origin of the second finites.

4. Consequently, the second finites now surround and enclose the same solar space ; since the first finites, for the forementioned reasons, have coalesced into the second. In the same manner these second finites, which are now next to the solar space, may enter into the space in considerable number and become actives. The solar space may thus be enriched and distended with actives of two kinds; being now supplied with the latter in addition to the former; and thus its power of acting upon the surrounding or inclosing particles may be increased. For if any finite should escape from its volume, aggregate, or expanse, into a space not consisting of contiguous particles, it is immediately rendered active; because it possesses the power of actuating itself. Thus the solar space may increase by means of a new' kind of actives, and act with a greater force upon the surrounding particles.

5. Both the first and second elementary particles may now take their rise round this large active space ; and may successively form a sphere which gradually grows larger, until at length they suffice to form a certain large vortex round the sun. For entities of both kinds are present, both actives and passives, of which the elementaries consist; since in the solar space are the actives, and round about are the finites, which consequently coalesce into particles and compounds partaking of both, and which, inheriting the force and character of both, receive into themselves both the active and passive principle. For this reason they are everywhere present in the world, everywhere they move and are put in motion ; they occupy and are occupied; they act and are acted upon both as to their distinct particles and as to their entire

volume ; and, possessing as they do a perfectly compressible, mobile, and highly elastic surface, they can flow equally under the pressure of a large as of a small weight. In a word, it is thus that, in general, they may originate in the confines of the active space, where an abundance of each principle is to be found; just as in virtue of these two principles, vapours and drops arise on the surfaces of liquids ; a volume consisting of actives occupying the internal space, and a volume of elementary parts pressing without. For elementaries can never constitute the surface of any particle, and be put in motion superficially, like the finites.

6. In the state of the formation of the vortex among the elementary particles, as they -are growing by accretion into an immense sphere or volume, no other force was needed than a certain active centre ; otherwise the elementary particles themselves would spontaneously dispose themselves into a general motion conformable to the figure of the parts ; and, by means of the action which takes place in the centre, they would perpetually continue this motion both as to each particle and also as to the whole volume. If, in a sphere of elementary particles, there is a centre of motion or an active centre, the parts which are nearest to the centre come into a state of greater compression than the parts which are more remote ; consequently there is an attempt of each particle to flow into a gyre corresponding to its compression, which is proportioned to the distance from the centre. Without a centre, all the motions would flow into the same circle; and indeed into the greatest of all, or into a right line ; but none into a less, and then proportionally larger, or into a common vortical motion ; for they all, without action or a space acting, are in their greatest degree of expansion. Hence if there is a centre and a force of activity in the centre, the elementary particles dispose themselves, by a mechanical necessity, into gyres conformable to their distance from the centre; that is to say, into a vortical motion.

7. The sphere of the elementary particles flows, entirely from the action of the solar space, into a vortical motion ; this motion must accord with the equators and poles of the parts; and hence must extend itself into a spiral form at a considerable distance from the centre; and must consequently by the motion and arrangement of its particles form a zodiac, etc.

8. Elementary nature is similar to herself both in the greatest and least things; in the macrocosm and in the microcosm ; in a heaven and in a small volume; in a world and in a particle. In a word, we may perceive its form and similitude to be the same, in the largest mirror as in the least; it is visible, however, to the eye only in a large one, that is, not in a simple but in a compound. Nature is a motive force diversely modified ; a motive force diversely modified is mechanism ; mechanism is geometry acting, since it cannot be otherwise than geometrical; geometry is an attribute of every entity endowed with figure and space; it is consequently inseparable from every particle and compound, whether at rest or in motion; it is inseparable also from motion itself. Therefore throughout the world it follows nature from its first origin, seed, and ovary ; from the least dimension to the greatest; and since geometry is the same in the greatest things as in the least, therefore also nature, so far as it is a motive force and modified, so far as it is mechanical and geometrical in either extreme [the infinitely large or infinitely little] is perfectly similar to itself. Hence we may contemplate the whole world in a volume ; a volume in a particle ; a particle in a corpuscle; a corpuscle in a simple; and reciprocally a simple in a compound ; a compound in a volume; a volume in a world ; a world in a heaven ; proceeding thus from the infinitely small to the infinitely great. Nature, therefore, is largest in what is least, and least in what is largest. And since the world is not visible except in things large and compound, we may, therefore, draw conclusions from the large to the less, and the least; as also from the large to the larger and the -

largest. The same parts and elements are in the least things as in the largest; in a small volume as in the great heaven. If the causes are like, like effects will result. Such as are the principles, such are the principiates. They cannot be varied as to effects unless they are first varied as to causes. If the same causes remain, the same effects will present themselves. If  $a$  be a cause and  $b$  an effect, then if there be a thousand times  $a$ , there will be a thousand times  $b$ ; and a thousand times  $a$  to a thousand times  $b$  is the same ratio between the causes and effects as that of  $a$  to  $b$ . Thus from the particles we have above described, or from a minute volume of these particles, we may learn the nature of the starry heaven and of the vast solar vortex ; from the lowly hovel we may ascend to the palaces of the skies, with all their sublime and magnificent courts; from the dust, to the stupendous arch of heaven studded with so many, and such mighty stars, and enriched with such beauty. Before, however, we can venture to raise our minds to the contemplation of this subject, we must first turn our attention to elementary nature, as exhibited in her lesser heaven and world; or in the volumes and sphere surrounding the magnet.

END OF PART I.



# THE PRINCIPIA.

PART II.





# THE PRINCIPIA.

## PART II.

### CHAPTER I.

#### THE CAUSES AND MECHANISM OF MAGNETIC FORCES.

In the former part of our *Principia*, we arrived at that element of the world which may be called magnetic; the first in which elementary nature presents herself as visible to the eye. Here it is that she begins to emerge out of her hiding place, and from darkness to issue forth into light. Here it is that she discloses to view many of her mysteries ; that she presents an image of herself as a whole; that at the very first glimpse of herself, she overwhelms, as it were, and confounds our senses by the forces with which she has invested a rough, dark, common, and heavy body. This body is the magnetic stone ; which may well be called the *lapis lydius* or touchstone of the learned ; which to the minds of philosophers has been as much a source of perplexity as it has been to their senses one of delight, and to both a subject of wonder. Here it is that phenomena first present themselves to the eyes, and that we can make experiments, by which, as by a touchstone, our principles may be examined and tested. We may here see whether they are as much in harmony with experiment, as they appear to be with the principles of mechanism ; and whether our principles can be confirmed by experiment, the prior by the posterior, the unknown by the known. Principles cannot be better tested

than by weighing them in the balance against experiments. In the first part of my work, I have had occasion to observe that I had formed principles without the evidence of experiments ; that I had nothing to appeal to for proof before I had advanced to another world-element; that if there were a mechanical connection extending in orderly sequence from the first point to this element, and if the theory of this element could be proved by experiments, these also would confirm the theories of the antecedents, in virtue of their connection with this element. At this element, then, we have now arrived. We have now placed ourselves in a world which is rendered visible by phenomena and experiment. Let us then proceed to ascertain whether there is any agreement, and what it is, between our principles and the phenomena to be presented to view; whether, in a word, our principles will endure the test of magnetic experiments, and consequently deserve to be considered as experimentally verified.

To ascertain this fact, we must first revert to the theory of elementary particles of which we have spoken in chapters V. and IX., part I., where we have drawn our conclusions with regard to the motion of their volumes, from the mechanism of the arrangement, motion, and figure, of the parts; as stated in the following propositions.

1. The first elementary particles and also the second, or the magnetic, have the most perfect aptness and susceptibility to motion. For, as we have there abundantly shown, if they are spherical in form, having surface only, and resemble a bubble, as it were ; if also they are highly compressible and elastic; and if in every state of compression they are equally mobile and always of similar form ; then they must have the greatest susceptibility and aptitude to motion, like elementary parts of all kinds. For every one of them has its own mobility; every one contributes its own little share to the general motion of the volume; every one in miniature resembles the whole volume, both as to form and motion. For the elemen-

tary particles are parts of the volume, and of the motion; they are all active and passive in the same way as the volume, and have thus the same principle of acting and being acted upon. For this reason they are perfectly apt for and prone to motion : and they spontaneously endeavour to enter into a vortical motion, provided there is an active centre round which they can gyrate. For in every particle there is a force tending to gyration, and the forces in the volume are multiplied according to the number of the particles ; there is hence a general effort in the volume, because there is a particular effort in every part. These forces, as we have shown in part I., tend to a circular motion. In order, therefore, for them to pass into this motion, there is nothing wanting but an active centre; and all that this centre does is merely to put them in motion ; the very particles afterward dispose themselves into this motion and direct it—a motion concordant with the force of each particle, namely, a vortical or gyratory motion round a centre.

2. In a volume of elementary parts all the motion is diffused and derived from a certain centre, where the origin of the motion exists, to all the parts round about; and to a greater or less distance according to the force of the centre, and the contiguity, elasticity, and yielding nature of the parts. For all the elementary parts are mobile of themselves ; and as they are contiguous, the motion is diffused and sent on from one to another, and indeed on all sides round about. Wherever there is anything contiguous, there also is diffusion of motion; where contiguity ceases, the motion ceases. Undulation can proceed to the limits of contiguity, but no farther. In the common elements we see the same contiguity everywhere presented ; hence also in these we perceive their motion diffusing itself into all their parts, as in the case of waves in water, tremors in the air, and undulations in the ether ; which the ear and eye perceive in every periphery, and at every distance from the centre, provided the distance be not too great. The same contiguity exists in the volume of the elementary

magnetic parts. If there be less contiguity, there is less dispersion and distribution of tremors and undulations. The motion may spread out from the centre to greater or less distances or circumferences, according to the elasticity or yielding nature of the surfaces. For what is elastic gives up to one adjacent particle the same force that it received from another. It restores itself to its own space, nor does it lose anything; whatever it receives it communicates, but not at the same instant; for having first withdrawn itself into itself, it then expands itself at its own proper rate. The rate of the diffusion of motion among elastic bodies is thus different from that which obtains between the particles of solid bodies free to move.

3. But the motion among the elementary particles not only is propagated and extended according to the form and natural arrangement of the parts, but it also terminates in them. Because among the elementary particles, every part, as we have before stated, contributes its share to the motion and form of motion in the volume ; it follows that the volume of the particles cannot be moved, or determine the form of its motion, in any other way than the individual parts allow. Hence the motion of the volume must be perfectly in agreement with the motion and form of the parts. If the elementary parts were exactly spherical, the motion would spread itself around into the form of a sphere, and describe perpetual circumferences equidistant from the centre. If the parts were not exactly but only partially spherical, then, where they were spherical, the motion would spread out and diffuse itself in a like spherical manner; while, wherever they were not spherical, they could not spread out in a spherical form and spherically extend their figure of motion. For in the case of elementaries we may contemplate a volume in a particle, and a particle in a volume ; we may deduce a general figure from a particular, and a particular from a general; so also may we with regard to a motion or a figure of motion. Thus the motion of elementaries in a volume is

in agreement with that of the form, arrangement, and motion of the parts ; according to the theory explained in chapters V. and IX., part I. And since the distribution of the motion in the volume is according to the form and arrangement of the parts, the motion must finally terminate in the same arrangement with that of the parts, or in that arrangement in which the parts themselves are. These details being purely mechanical, follow by mechanical connection and necessity.

4. Hence we come to the conclusion, that the motion among the first elementary particles, and also the second or magnetic, is diffused in every direction from the centre to all the circumferences. But as the form and arrangement of the parts is such that the poles of all the particles, and also the equators, are all parallel, it follows that the motion among the particles is diffused in one way according to the poles, and in another according to the equators. For if the general motion be formed and set forth according to the form and arrangement of the parts, it follows that it cannot diffuse itself among the elementary magnetic particles from the centre to every angle with a like uniformity; that is to say, it cannot extend itself spherically into circumferences continually concentric or equally distant from the centre, but must move in a manner in agreement with the form and arrangement of the parts ; in one manner according to the parallelism of the axes, in another according to the contact and parallelism of the equators ; the axes and equators being the points and quarters that determine the direction of the general motion, and incline it more and more to the original form, into which it is thus brought by mechanical necessity.

5. Since the diffusion and propagation of motion from the centre, is of one kind according to the plane or parallelism of the poles, and of another and different kind according to the plane and parallelism of the equators of the parts ; it follows, that the motion cannot be diffused into circumferences equidistant from the centre, or similarly circular, but only into such as

are spiral. For if the motion, according to the polar plane of the parts, is different from the motion according to their equinoctial plane; and if this motion is nevertheless diffused from the centre to all the circumferences ; it follows that the motion diffuses itself more widely and quickly to one part than to another; that two motions are thus derived from one centre; and consequently that all the intermediate motions are proportional to these two, and cannot be extended or continued to any distance except in a spiral manner. A motion of this kind in a volume of parts is truly vortical; inasmuch as it propagates itself by spires to various distances, and thus spreads itself in every direction.

6. In this spiral or vortical motion, the nearer the spires are to the centre, the greater is their curvature ; the further off they are, the less is their curvature, till it gradually ends in a right line, and thus in the arrangement of the elementary particles. This follows from the former proposition. If the motion tends to the natural arrangement of the parts, in which it finally ceases ; and if nevertheless it runs in circular directions from the place of its first beginning or centre, then it will at first form spires of greater curvature, and of less in proportion to its distance from the centre ; till at length, instead of a spire, it will describe a right line conformable with the parallelism of the axis of all the parts. For if the figure of motion becomes the more rectilinear according to the greater distance, and if it thus extends itself the more, in conformity with the arrangement of the parts ; if also the figure is spiral or vortical; the spires will extend and unfold themselves more and more from a perpendicular and oblique into a right line. Imagine for a moment similar and larger particles moving among one another, and all having a parallel arrangement; the motion cannot expand itself in any other manner than according to their arrangement in the direction of length and breadth ; and the figure of the spiral motion will be more and more extended, according to the axis; when the motion ends, it will end according as the parts lie. The like also is

the figure of every part. The end of motion is rest; the arrangements of the parts is the state of their rest, the motion terminating in a state of rest must, therefore, be rectilinear.

Finally, all motion between the elementary particles, which

Fig. 1.

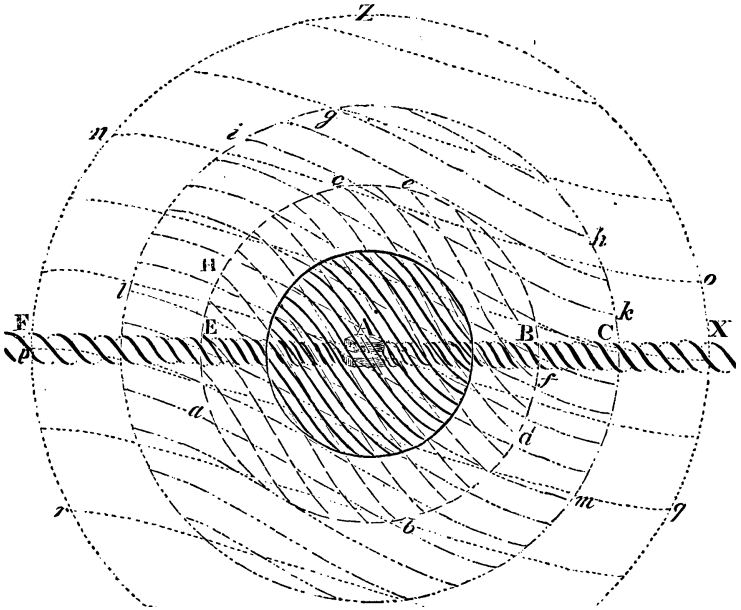

we have called magnetic, runs round a centre in a spiral direction; and when it has arrived at its state of rest, comes into a rectilinear arrangement, and into the same with the arrangement of the parts at rest. In this consists all the magnetism treated of in the sequel.\* Let A be the centre of motion, round which the elementary particles are distributed. Let the distances from the centre be represented- by circles, and in the present case by three. The spiral motion round

the centre is of greater curvature nearer to the centre, as  $/e$ ,  $tZc$ ,  $l)H$ , and is evidently like the helix or spire in B, which we have drawn here only for the purpose of assisting the ideas of the reader. At a greater distance from the centre, the spires are of less curvature as  $hg$ ,  $ki$ ,  $ml$ ; at a still greater distance, they have a still less curvature as  $on$ ,  $qp$ ,  $sr$ ; and at a distance still greater, they have the least possible, or become rectilinear.

What we have here said of the motion of elementary particles, agrees with the principles laid down in the first part of this work; indeed, there is not the slightest difference between them. We have there affirmed, for instance, that the elementary particles are most highly elastic, yielding, and adapted to a vortical motion; that they are also most perfectly susceptible to this motion, purely from the action of a given centre spontaneously tending to this motion; that these particles cannot enter into any other motion than such as is consonant with the form and arrangement of the parts; that the only motion conformable to this form and arrangement is the spiral; which ultimately, according to the arrangement of the parts, passes into the rectilinear; that the curve of movement is consequently greater near the centre, and less proportionately to its distance from the centre; the consequence of which is that a vortex is formed. Nor must we omit to mention, that the motion which is according to the axis of each part is more refractory, resisting, and, so to speak, firmer than the motion which is distributed according to the equator of each. At the equators the particles, according to their mechanism, appear to be the most highly yielding; and, at their contact there, are most highly elastic and sensitive, but not so at their contact at the poles. Hence arises the difference between the motions; hence the spiral form; as also the termination of the motion in a right line. A sufficient reason for these things, however, may be found in the mechanism of the form itself, as described in our foregoing remarks.



7. These spiral gyrations which arise from a certain active centre, we may, in what follows, call vorticles; and every gyration round its own proper centre, a single vorticle; for the motion is entirely and truly vortical from the centre to the circumferences. From the connection between our principles it follows further, that there may be as many spiral gyrations or vorticles as there are centres of motion ; and that the vorticles may be conjoined with one another in a manner conformable to their figure and motion. For if there are several centres of motion, then there will be several spiral motions, spiral gyrations, or vorticles. For the particles are so ready for and susceptible to this motion, that they have no need of anything but centres, at which the motion may begin, and round which, when begun, it may take place. When there is a centre, then a gyration takes place round the centre. If there are several centres, then there are several vorticles close to one another; one within, another without, the sphere of the other. Just as is the case with waves in water, one of which follows close upon another, provided the volume be put in motion from a centre ; also with tremors and vibrations in the air, in which case one follows the other closely, provided the air be disturbed by some vibrating force at a given centre. We may see a similar illustration in undulations of the ether, the centres of which may exist within as well as without the sphere of any other undulation or modulation. Thus

Fig. 2.

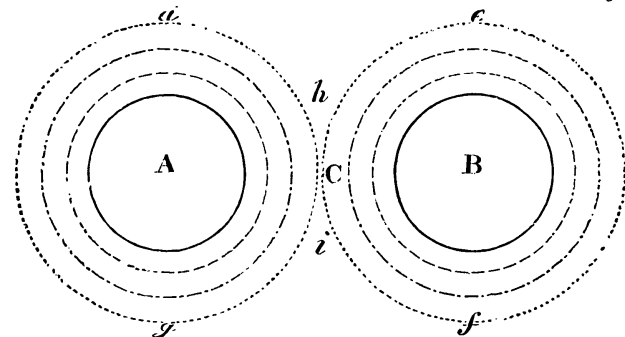

A and B are two centres, from which the motion propagated is represented by circles. If by the intervening circles these centres are conjoined at C, then the circles  $\langle ? \rangle$ ,  $dg$  may mutually extend themselves into each other's sphere; and thus, as far as regards motion, the sphere of one may enter the sphere of the other. The case is the same also in the exquisitely subtle elements of which we are treating. Gyration or vorticles may travel from various centres, either without or within the sphere of another. Nature is always most perfectly similar to herself, especially in the elements. Since, therefore, there may be as many vorticles as there are centres of motion ; and since one may be near another ; it is to be observed that vorticles cannot possibly be conjoined with one another unless in a manner conformable to their figure and motion ; and unless the gyration of one is concordant with that of the other, the motion of one with the motion of the other; and unless also the spires of each vorticle are concordant with one another as to their mechanism ; so that the plane of the motion of one may accord with the plane of the motion of the other, and the current of the one with the current of the other, that is to say, so that they may be conjoined according to the current of their spires. In fig. 3 we

Fig. 3.

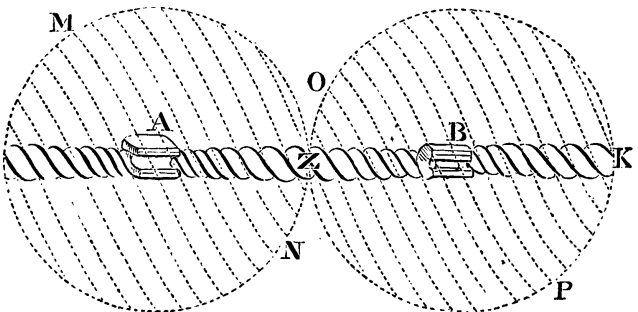

see two vorticles of the same kind, the centres of which are A and B; the spiral motion of each is in a direction from O toward P, or from M toward N; if the currents of the spires,

or the planes, are in the same parallelism, this is the state in which the motion of each is capable of being the best conjoined ; and one vorticle may continue its gyration near another without any resistance or retardation. If therefore the vorticles are to be reciprocally conjoined, this conjunction must take place in the current and curvature of the spires. Thus if we wanted two pulleys or two screws always to act together, the obliquity of their planes must be in accordance with each other ; in which case alone can the two be properly conjoined. Were the relative position of each, and their mode of conjunction, the one contrary to the other, the result would be a conflicting motion between the two ; and from two contrary motions, would arise a certain quiescence of the parts or else an extinction of the motions. Thus in fig. 4, the circles of

Fig. 4.

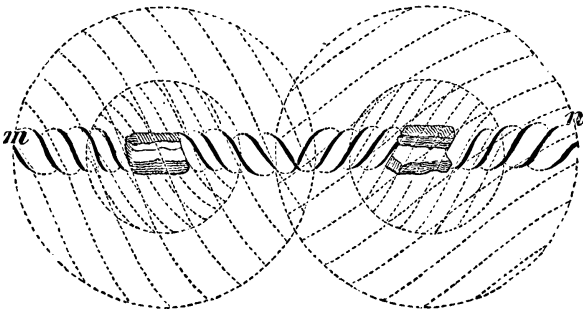

one vorticle run crosswise to those of the other; and in a motion of this kind the current of one opposes the current of the other; hence they tend mutually to stop one another, and to bring one another into a state of rest. We see then the manner of conjunction of these vorticles ; a conjunction which is mechanically the closest possible when the current of one corresponds with the current of the other, and when the plane of motion of one has the same obliquity as the plane of motion of the other. Moreover, as the figure and arrangement of the parts is the same with the form and arrangement of the compound or volume, in the elements, so,

according to the general rule laid down in our first principles, it follows that the conjunction of the volumes vortically moved, or of the vortices, will be similar to the conjunction of the parts which are conjoined with each other only at the poles; so that there is thus a parallelism of axes, and a harmony of motions.

8. If the vortices are united according to their spirals and the harmony of their motions, they are, as it were, mutually bound together by the union ; and tend to remain in it. For they do not easily suffer their arrangement to be altered ; for the spire and motion of one has most concordantly, naturally, and mechanically, entered into the spire and motion of the other. Thus the vortices, bound most closely together by their concordant motion, cohere as it were. Were they reduced by any force to any other arrangement, their very plane and power of motion would oppose the change, and forbid their separation ; when thus united they remain in their own natural arrangement, from which they cannot be displaced except by force. If innumerable spirals, formed by motion, were brought together, the motion would scarcely permit them to be separated, and the difficulty would be the greater the more intense the motion, and the greater the curvature of the spirals. Everything that is contrary to the mechanism, is contrary also to the force, conjunction, and potency of the parts. Hence when two vortices of this kind are conjoined not in one oblique plane, or one spiral of motion, but in many and innumerable, they cannot be dissolved and dissociated except by some kind of extinction of their motion ; by some change of their state or some force proportioned to the motion and the plane. Hence such vortices being harmoniously and mechanically conjoined in their motions, tend to remain united, and powerfully resist and oppose upon mechanical principles any force tending to change their arrangement.

9. Vortices, or spiral gyrations of this kind, have a greater tendency to conjunction and union with one another the nearer

they are to the centre, or the greater the curvature of the spires by which they are conjoined. As spirals which are nearer to the centres have a greater curvature than those which are more remote, so are they more strongly united if they coalesce with a greater curvature, than with a less; consequently they unite with each other the more strongly, if they are nearer to the centre, than they would if they were more remote. The motions of a spiral are of greater curvature at the centre of motion ; of a less at a farther distance ; while at a distance still farther the motion almost ceases to be spiral, and becomes nearly rectilinear, consequently there is no union between the two. Besides, the nearer gyrations are to their centres, the greater the curvature and the more numerous are the spirals by which they are conjoined, or the circles inflected into a spiral motion ; the conjunction being secured, so to speak, by chains wound round them the more frequently.

Hence we infer that the closest union of motion is nearest the centre of motion; because there the gyration has the greatest curvature ; in the intermediate distance, the degree of union is intermediate; at the farthest distance there is none ; inasmuch as the gyratory motion there begins to be determined into a right line. Moreover, union exists wherever the angle of the spire is less than forty-five degrees. It follows also, that the more numerous the centres of motion in the same plane, the greater also is the gyration and union of the vorticles; the fewer in the same plane, the less is the union; also that there are as many unions as there are centres of motion ; not to mention other particulars, which, as they necessarily result from the same mechanism, do not require any special notice.

10. Bodies having pores and interstices so minute as to be permeable only by magnetic elementary particles, are magnetic bodies; especially if the pores or interstices are rectilinear. In hard bodies there are particles diversely arranged, as also diversely furnished with pores; there are pores which are more open and larger; pores also which are

smaller, according to the nature of the compositions, of which we shall have to treat in our theory of the mineral kingdom. I hold, however, that bodies of every form are magnetic ; provided the elementary magnetic particles can pass through the pores and connecting parts of their structure, and which are not large enough for particles of a grosser element. Of this kind are the minute particles or effluvia proceeding from magnets and iron ; as will be evident in the sequel, from the phenomena which will be adduced. The magnetic substance itself is of the nature of iron, and is found in all parts of the world. Iron is a mineral the most common, and the most universal in the mineral kingdom. Particles of iron are found in almost every kind of soil as experience testifies; the very ground itself is full of them. Rivers, fountains, and lakes are often heavy with iron and abound with its vitriol; as is evident from their sediments and impurities. Plants themselves are also impregnated with iron, as is evident from their ashes ; in a word, the mineral most generally prevalent upon our earth is iron. It is no wonder, therefore, that in iron, the pores of the smallest parts or of the effluvia, are formed in accordance with the arrangement of the elementary particles. The arrangement of the particles of this element, according to the principles we have laid down, is rectilinear ; and if these particles lie upon the surface of the earth, and are present at the formation of this very widespread metal, it is no wonder that its spaces and extremely minute interstices should be fashioned in accordance with the arrangement of these particles and consequently be rectilinear. For the most subtle elementary particles continually enter into and penetrate the texture of the harder bodies ; and by their perpetual flow and reflow create for themselves in the course of their permeations passages perfectly similar ; that is to say, rectilinear. From these circumstances alone it might be concluded that there are particles of this kind so small as to issue and exhale from hard bodies in the form of effluvia; and that these particles are penetrated and

rendered pervious only by the most subtle elementary parts ; and this too in the direction of a right line, or conformably to the arrangement of the particles of the element. Were the minute interstices above mentioned not rectilinear but inflected at various angles, they could not possibly be magnetic, as we shall see in the sequel.

11. Particles of this kind, or effluvia, when free, cannot be quiescent; but gyrate continually round their centre, according to the arrangement of the elementary particles. They constitute therefore active centres, and form around themselves spiral gyrations or vortices. If now the minute interstices occupied by the effluvia are crowded, and filled only with magnetic particles, these particles cannot possibly be quiescent; for the other enclosed elementary particles have themselves a perpetual axillary motion, as we mentioned in our theory of these particles; and consequently, together with these, the particles or effluvia whose interior texture and interstices they alone fill and, as it were, distend. For the elementary particles are both active and passive, since they partake of both principles; they are apt and ready for motion; consequently if the magnetic particle be free, they give it an axillary motion. And even if the enclosed elementary particles do not act, still there are others which touch and press upon the surface of the particle, and put it into this motion ; and if by any internal or external cause they are put into a gyratory motion, it must be a motion in agreement with the arrangement of the elementary particles occupying their interiors and exteriors. The elementary particles which are within flow connectedly with those which are without ; nor can they, by reason of this connection, circulate in any other way than in a kind of rotation, or with a common motion ; that is to say, with an axillary motion similar to the axillary motion and arrangement of the elementary parts. So that in the very smallest element or separate part of a magnet, there is a polar arrangement and relation. Thus in figs. 5 and 6 the effluvia are represented as exposed or lying

Fig. 5.

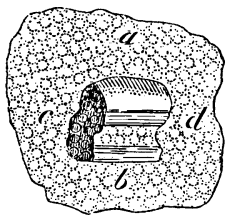
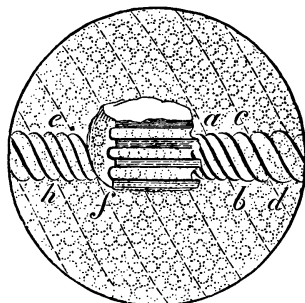

Fig. 6.



open on both sides with rectilinear pores ; elementary particles occupy their interior texture or channels, and also flow outside ; and, because these included elementary particles are bound together in that particular way, they compel the effluvia to rotate about that axis which they themselves observe and form. In case, however, the pores were not rectilinear, but variously twisted, bent, and led about unequally and without regularity, no axis would be formed, nor would there be any general consent to an axillary motion ; but one part would endeavour to gyrate a particle according to its arrangement and angle, another part according to its arrangement and angle, and thus all together, in an uncertain, indeterminate way, or to no arrangement and angle. A rectilinear arrangement or channel of the pores is therefore requisite.

12. Accordingly, such as is the number of magnetic effluvia, such is the number of vortices. formed round the magnet; one or more will be within or without the sphere of another or neighbouring vortex.

13. The greater the quantity of this effluvia round a magnet, the greater is the number of centres and vortices ; also the more nearly and closely they may be conjoined and united by their interior spirals; and *vice versa*. Inasmuch as the centres may be active to a considerable distance from themselves, and near together one may rotate and perform



a spiral gyration in the same manner in the very vorticle of another, it follows that the more centres there are, the nearer are the vorticles in contact with one another, and they conjoin themselves with the more interior, more curved, and more associated spirals, as we have previously shown.

' 14. The natural place of the effluvia is in the centre of this vorticle ; nor can the effluvium, residing and acting in its centre, project itself out of the vorticle ; for it is inseparable from the vorticle, and is naturally carried in the direction in which the vorticle moves, and contrariwise. For if the spiral gyration or vorticle arises from a certain centre, then the vorticle without its centre is nothing; if the centre is wanting, the gyration is wanting ; hence wherever there is a centre, there is also a gyration. The centre is thus inseparable from its circumferences. The vortical circumferences, together with the centre, constitute one motion; the centre, therefore, follows its own motion, and the motion follows its own centre ; nor can the centre project or convey itself out of the vorticle ; for this would be to separate one and the same thing from itself; in other words, to annihilate it.

15. If within any hard or material body there are effluvia, or smallest parts of this kind, both free and associated, but extending in a right line or in a regular curve from one side to the other, or from one pole to the other, then, I hold that such a hard or material body is wholly magnetic. For instance, if the mass, or mineral, or hard body, be one through which effluvia of this kind not only flow, but into whose composition they enter, then this body possesses a magnetic force; provided the arrangement of the effluvia is in a right line or a regular curve extending from one extremity to the other; since the vorticles are bound by inmost spirals and circles, not only to the body, thus connecting as it w<sup>T</sup>ere one side of the body with the other, but also to the effluvia of the same kind which flow externally to it, or which are in its boundaries. And thus it is that the whole body, from one pole to the other,

together with the entire sphere of vorticles which flow without, presents itself as magnetic. If the effluvia filling the hard body were not conjoined in a right line, but occupied such a position as to be everywhere at an uncertain angle, they would also conjoin themselves at various angles with the circumfluent effluvia, and would form with them irregular connections; so that one vorticle could not adapt itself to the spirals or current of the other; one could not enter into the motion of the other; the vorticles would not conjoin and bind themselves together in any series, according to parallel planes, but one would interfere with the free action of the other, by crossing it at one time obliquely, at another at right angles, and at another by moving in an entirely opposite direction. Thus would one not only disturb the circles of the other, but

Fig. 7.

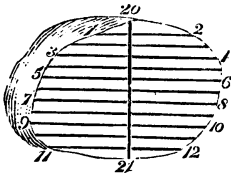

extinguish and annihilate them ; consequently the situation of these pores within the structure of the mass ought to be rectilinear or regular; as in Fig. 7, where all the ducts lead in rectilinear and parallel directions from one side to the other, as in the case of those marked 1,2;

3, 4 ; 5, 6 ; 7, 8 ; etc.

16. The more regular the arrangement of the particles, and the greater their quantity both within and without the mass, the closer is their union and the stronger the magnetism. For magnetism itself consists in the union of the vorticles within and without the mass and in the confines between the two.

The more regular the arrangement of the parts within limits of the mass, the more regular is the arrangement and conjunction of the vorticles without the mass. Thus one is connected with another in a continuous series ; and all are disposed together more conveniently into one sphere; a contiguous extense is formed round about from one pole to the other, and vorticles in connection with one another everywhere enclose the mass, bracing it round, as it were, and binding it close to themselves. If, however, the arrange-

ment of the outgoing effluvia is irregular, then the motions are discordant and interrupted and the magnetism ceases with the cessation of the connection and contiguity of the parts.

17. The union of the effluvia or vorticles is closer at a less than at a greater distance from the mass; and closest at its confines or boundaries, or nearest to the mass. Near the point of exit or in the very wall of the mass, whence the effluvia proceed, and whence they diffuse their particles conjunctively throughout the sphere from one pole to another, or from one wall to another, there must necessarily be in a given space a larger quantity of effluvia ; and consequently at this place the vorticles reciprocally embrace one another with their spirals the more closely ; while at a distance from this point, where they have more room for flying off, the vorticles are fewer and consequently are held in conjunction by spirals of less curvature, having a more feeble potency, and a weaker force ; therefore the nearer they are to the polar wall, the closer is the bond of connection, because the greater is their quantity in a given space.

18. The vorticles surround this mass by a continuously connected link from one polar wall to another; and thus connect and enclose each wall and pole by means of a kind of sphere. For not only do the effluvia exhale from each wall of the magnet, but also immediately connect and link themselves with the surrounding effluvia. Thus the two conjoin themselves one with another, and extend from one polar wall to the other. Since the magnet is surrounded with effluvia both at the polar walls and at the equinoctial, that is, both above and below, both directly and obliquely, the vorticles of these effluvia necessarily coalesce, by a similar motion of all, into one sphere ; but this can be done mechanically only from pole to pole by a regular incurvation and figure, as in Fig. 8, in which *g* is one polar wall where the vorticles flowing round are first consociated and conjoined with those which press and as it were lie upon the mass. *A* is the other polar wall,

Fig. 8.

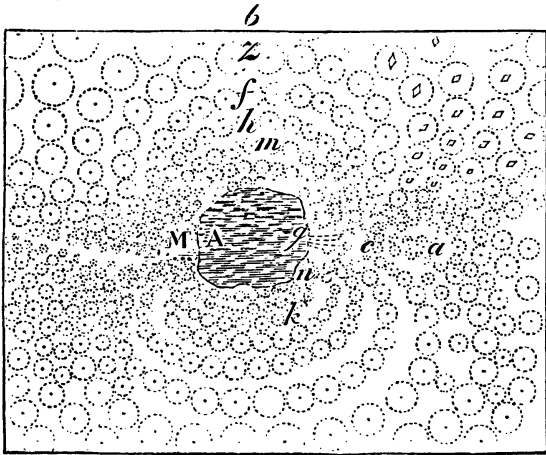

where, similarly, the effluvia flowing around are linked with those which contiguously press upon the wall, and these cannot<sup>T</sup> but be united into one sphere, from one pole to the

Fig. 9.

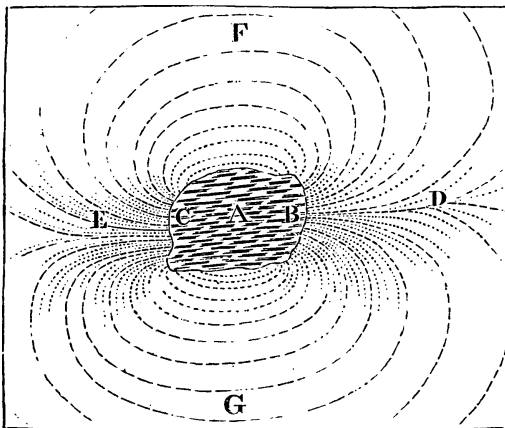

other, as we may see also in fig. 9. By this sphere, therefore, a figure similar to the oval is formed, and the axes of the vortices are inflected in agreement with its curvature or surface. For if the centre in the middle is active, and if the motion of the surrounding elementary particles is spiral, and if there

are several or numberless vorticles of this kind near one another, then one vorticle will adapt itself to the other; the motion of one will direct and turn that of the other, and will adjust the obliquity of the neighbouring vorticles<sup>^</sup> together with the effluvium itself, to the plane and angle of its own current. Thus it will bend the axis of motion belonging to these, so as to adapt it to the axis of its own motion. The harmony and conjunction of all consist in the similarity of the streams of motion, and in the reciprocal application of one to the other. Hence, without any break in the motions and flowing spires, either the effluvium and with it the vorticle, or else the axis itself of the vorticle, may be bent obliquely and consequently into any curve.

From what has been said it also follows that the sphere of the vorticles thus connected may endure for a considerable time round the whole magnet; nor is there any need for it to be constantly renovated with fresh effluvia ; also that no great quantity of these continually outgoing effluvia is required. It follows also, that the magnet itself, surrounded with such a sphere of vorticles, cannot possibly be removed from one place to another, without removing the whole sphere together with it; that the sphere itself cannot be removed from one place to another without removing the magnet together with it; that the magnet and sphere constitute, as it were, one body ; and that one cannot be separated from the other, much less be moved away from the other, but that the magnet in the centre of its sphere (in whatever situation and motion) naturally always accompanies the sphere, and the sphere the magnet. With regard to our last position, namely, that the magnet always accompanies the sphere, and the sphere the magnet, this is evident from what has been said above ; for since the vorticles at a distance from the magnet are perpetually and reciprocally tied and bound to one another, and those which are nearer the mass more closely than those which are more remote ; since there is thus a connection between them all and the mass itself, it follows

that one depends on the other by contiguous connection, like one continued and chain-like series ; so that there can be no magnet unaccompanied by a sphere, nor any sphere unaccompanied by a magnet ; and that, as is evident from fig. 8, there is a continuous connection between them extending round about to a considerable distance. Nor can one vorticle move out of its place, and be withdrawn from a connection with the adjacent ones, unless the adjacent and nearest vorticles themselves are removed and withdrawn, or undergo some change ; and this even up to the magnet itself, where the union is the closest; so that the magnet itself, thus conjoined with these vorticles by contiguity, or by a continuous connection of the spiral motions with every part of the sphere with which it is surrounded, is rendered subject and obedient to every change of the sphere.

19. By reason of the connection between the vorticles which extend from one pole to another, and of the formation of the sphere, there are poles, one being on each side of the magnet. In a similar manner there are polar axes extending in the sphere to a distance from the magnet ; and these axes do not receive their direction from the magnet, but from the sphere and its figure. That not the magnet but the sphere forms the polar axis on each side, is evident from this fact, that the polar plane passes through the whole magnet from one side to the other; as in fig. 10, where the whole side *fog* is

Fig. 10.

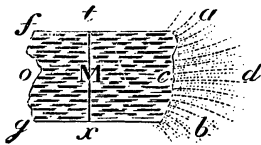

polar, as also the opposite side *acb*, and the elements of the effluvia travel within the mass rectilinearly from *fog* to *acb* according to the interior structure. Hence the polar axis cannot have any fixed place in the magnet, but the place

and situation of the poles are owing entirely to the sphere, which is compelled to encircle the magnet according to the figure of the latter ; thus sometimes in one way, sometimes in another. The sphere itself, which extends from one wall to another

and consequently bends itself round by a certain curvature, forms a pole or polar axis in the place where the vorticles begin to bend in their course. Hence all the vorticles which are connected together proceed at first according to this axis, in a right line from the magnet; and then deflect themselves from the axis, in every direction, into a curve. This we may see in figs. 8 and 9 (p. 252), and also in fig. 11.

Fig. 11.

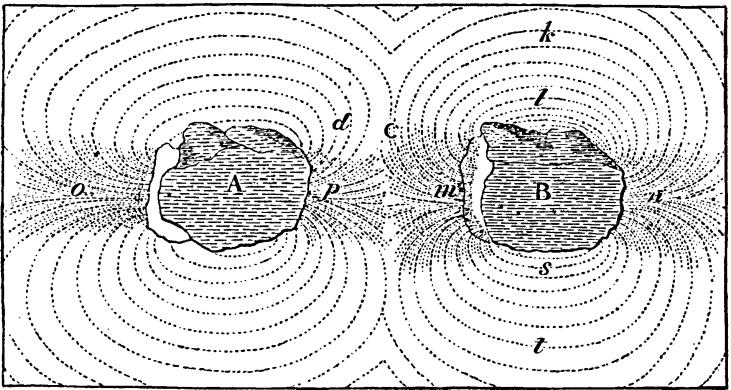

20. The axes of the vorticles are not parallel to that of the sphere ; but are deflected according to the figure of the sphere ; and this deflection begins at the polar axis of the sphere. For the vorticles diffuse themselves round the magnet in a connected series from one pole to the other; the motion and spiral of one applying itself to the motion and spiral of the other, until from one pole, by their continual bending and mutual application, they reach the other pole ; and by the application of their motions and their situation thence arising, thus bind both the poles together, or enclose the magnet, so bound on both sides, by one continued gyration. And since the motions of the vorticles are thus mutually applied to one another, it necessarily follows that their axes also must mutually adapt themselves to one another and be entwined. Hence the axes of the vorticles and the axis of the sphere are

not parallel; as will be seen more clearly illustrated in the figures.

21. The axes of the vorticles and the axes of the elementary particles round the magnet are parallel ; and the elementary particles are disposed by the motion of the vorticles into the same arrangement, and the same figure of arrangement with the sphere ; as will be shown in the sequel.

22. The whole motion in the vorticle is according to the position of its axis ; or the axis has a curvature conformable to the motion. If the axes are in a right line the motions in the vorticle are concentric ; if the axes are curved, the motions are eccentric ; if several vorticles are in the vicinity of one another according to whose motion and application the axes are to be curved, then there is a different eccentricity at different distances from the centre or effluvium. This is observable also in the large vortex of the sun, where the planets describe ellipses round their centre or sun, in one focus of which the sun is situated ; the cause of which we shall here briefly explain, as we are now treating of the vortical motion. For the magnetic sphere with its vorticles is a type and small image of the starry heaven ; there is the same kind of motion in small things as in great; because the element which has a vortical motion is the same in both. We must observe, that the arrangement of all the elementary particles round the magnet is according to the figure of the sphere ; and not only that there are vorticles which thus bend themselves from one axis to another, but that together with the vorticles the particles of the element are also bent; so that the elementary particles themselves are so connected as to their poles as collectively to form this figure. Thus in fig. 11 all the dotted lines are not only effluvia with their vorticles, but they are also the elementary particles themselves brought into a like arrangement; so that the magnetic sphere is to be conceived as consisting of elementary particles, bent into the same arrangement as that in which the points flow in the figure. For the motions and fluent spirals of the vorticles,



which by their mutual application bring one another into this arrangement, dispose and draw the elementary particles into the same arrangement : in a word, the arrangement of the elementary particles is the same as the arrangement of the vortices. If the elementary particles are imagined to be in this arrangement; and the effluvia or active centres between them to be placed in this order and figure; in this case I remark, that all the spiral or vortical gyrations arising from the centre apply themselves to the arrangement of the particles. And if the axes of the vortices are parallel, or the same as the arrangement of the elementary particles in this magnetic sphere, it follows that in some places the axes are straight, in others curved and more or less bent round. If the axes are bent round or curved, I say that the vortical motion thence arising is not concentric nor even circular, but eccentric and elliptical; in one focus of which is the effluvium, whose distance from the centre of the ellipse is proportional to the curvature of the axis. For the vortical or spiral motion goes out in all directions from the centre or the effluvium, and more and more unfolds and extends itself into a line parallel with the axes; that is to say, it fixes the axes according to its direction. If therefore the axes are curved, the spiral motion runs from the centres to the equators of the particles to a greater distance on one side than on the other; since the situation of the particles urges the motion in that direction ; and consequently by the motion spiral circles are formed, which, with respect to the effluvia, are not concentric but eccentric and elliptical. For were the axis not inflected in one but in different ways in consequence of the approximation or vicinity of several vortices, then various ellipses would be described by the spiral motion, at various distances from the effluvium ; none of which would have reference to one common centre; as is plainly the case with the ellipses described by the planets in the solar vortex. It is to be observed, that the axis of the vortice is equal to its entire breadth ; it is not formed by merely a brief motion from its centre, but extends

throughout the whole of the breadth occupied by the vortical motion as in fig. 1 (p. 239), where a vorticle is represented of a circular form. In this case its axis is not to be conceived as equal to BCX only, or to AEF only, but as equal to the whole breadth from X to F or from Z to Z. For all the elementary particles among which the vortical motion exists, are in this arrangement parallel to one another. Hence an axis of this kind, and of such a size, may be bent by the motion of the neighbouring vorticles in different ways; and consequently the motion may form various ellipses at various distances from the centre, or ellipses of different eccentricities. On this subject, however, I shall speak in the theory of the vortices and the planets.

23. The axis of the sphere, or the common axis of the vorticles, lies parallel with the common axis of the element itself, so as to be exactly accommodated to it; but nevertheless it may be easily diverted from this into any other direction. By a sphere we understand the entire combination and series of vorticles connected with the figure extending round the magnet. Inasmuch as the motion of all the vorticles has its termination, and ends in a common arrangement of particles or axes, it will consequently, if free, always be directed and fall into this arrangement by common effort.

24. The axis of the whole sphere, or the common axis of the vorticles, may be curved in a similar manner; and together with it, the sphere itself, from one pole to another, may also undergo any change ; or what amounts to the same, the sphere itself may from one pole to the other undergo a change, and in accordance with that change the polar axis will be bent. For if the sphere form an axis according to its figure, then, if the figure of the sphere be changed, the axis also is changed or curved and contrariwise. For the axis derives its origin from the sphere ; and where the vorticles begin to be curved around the magnet, there is the axis; if therefore another figure or arrangement of vorticles arises, there exists also another position of the axis.

25. By the application of two or more magnetic spheres, the figure of each is immediately changed. From two or more spheres arises one that is larger; and the whole of the distance between the spheres becomes an axis. For vortices, if applied to vortices, coalesce, as it were, into one volume; the motion of one immediately enters into the motion of the other; and thus arises a conjunction and union of the vortices ; for one vortex is conjoined as to its current and motion with the other ; if they do not coalesce, resistance and collision arise; for there is no equilibrium without a conjunction and harmony of motions. Unless there were this mutual agreement among the vortices, they would fly off in all directions, and the sphere would be dissipated ; hence they naturally unite together and connect themselves into a similar arrangement;

Fig. 12.

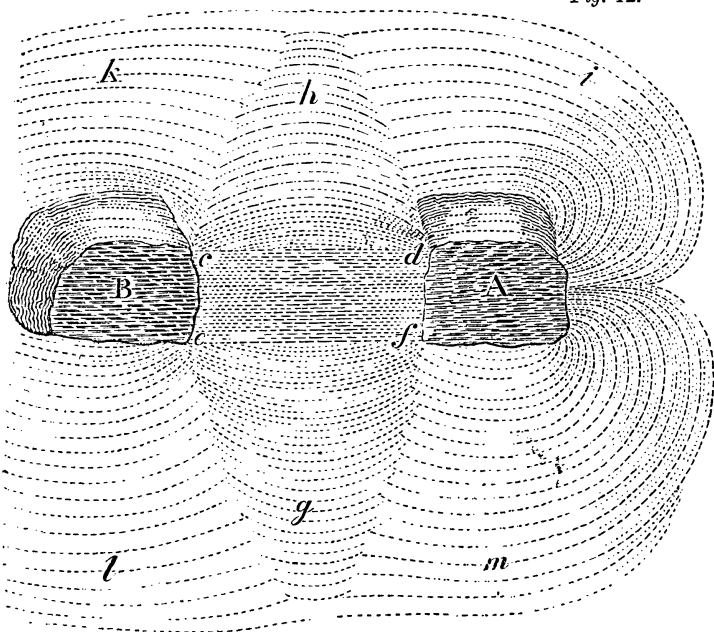

and this depends on those mechanical principles which we have frequently demonstrated. Homogeneous motions do not accord with heterogeneous ; nor like with unlike ; neither do

two contrary motions which are unable to form any equilibrium or mutual connection, except by a mutual application of their moving spirals. ^This we see illustrated in the case of fluids of every kind ; in which, by approximation or contact,, the volume of one commingles or confounds itself with that of the other ; a volume of water with water ; a volume of air with air, of fire with fire, and of mercury with mercury ; in a word, any one fluid with a volume of the same kind. More particularly does a sphere itself, or volume of vorticles flowing round the magnet, coalesce with an approaching new sphere ; for the motion will not permit separation or opposition of arrangement; consequently from two or more vorticles there arises one: as in fig. 12, where A and B are two magnets with their spheres. When the spheres are brought together, the motions of the vorticles are applied to one another; and in the union and similarity of their motions they seek and attain equilibrium. Hence arises a conjunction of all the motions between the two magnets; while the axis from being narrow becomes wide and broad, equalling in width the whole width of the magnet, as in fig. 13, where *ede, mno*, represent

Fig. 13.

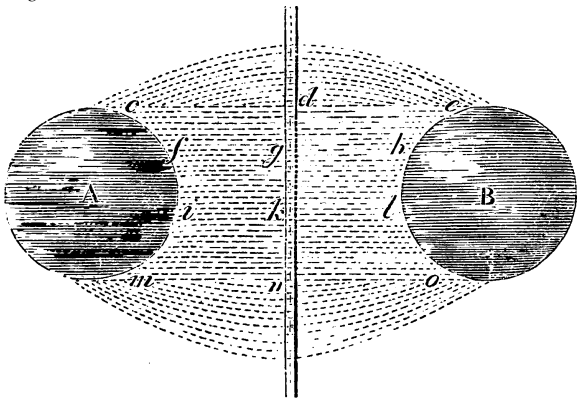

a broad axis between two spherical magnets or *terrellw*, as they are called, and A B its middle ; the vorticles, or spheres of vorticles, curve themselves round each magnet from this broad

axis as they do from a narrow one, and enclose it within one figure or sphere. The spheres may, however, be attached to each other in different ways, as for instance at the poles, or the axes, or at the equators ; also obliquely and intermediately^, the sphere of one magnet in a different manner from the sphere of another. And since the arrangement of the vorticles is various, and also the figure of the sphere, there may exist innumerable kinds of applications, and hence innumerable forms and diversities of figures, and conjunctions; and consequently various forces and powers. Hence according to the different application of the spheres, the larger sphere thence arising is differently formed.

26. Two or more spheres mutually applied to each other, are more closely united at a smaller than at a greater distance. For if the vorticles nearest to the magnet are in the closest conjunction and in a spiral and mechanical connection ; and those are in a less conjunction which are more remote ; then the two spheres are bound together more closely at a smaller than at a greater distance from the magnet ; as in figs. 14 and 15, where A and B are two magnets, and the intermediate

Fig. 14.

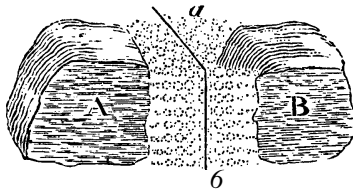
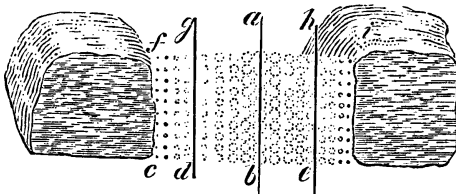

Fig. 5.



vorticles extending along the distance *ihcigf* are variously conjoined; some with spirals more interior, curved, and rapid, which are those nearest to the magnet; others with

spirals less curved and rapid, which are those farther off from the magnet ; as for instance, the vorticles in *he* or *gd* which are more closely connected, because we not only find here a greater abundance of them, but they are more nearly conjoined with those which rest on the magnetic wall; while in *ab* there are fewer vorticles, and they are consequently conjoined with one another more loosely, and with spirals of less curvature. If therefore the magnets are brought still more closely to one another, as in fig. 14, the spheres touch each other with spirals that are closer to one another, and more closely linked, and so are more strongly united. The same things may be seen illustrated in figs. 16, 17, 18,

Fig. 16.

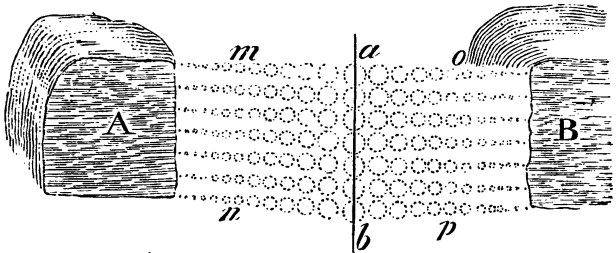

Fig. 17.

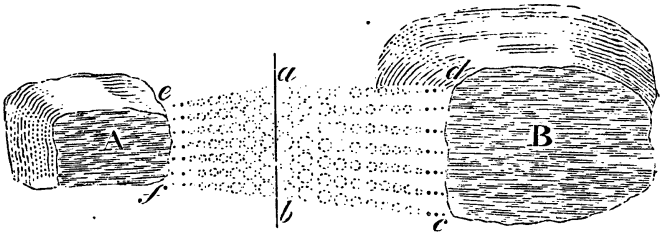
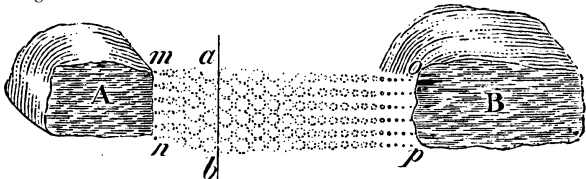

Fig. 18.



where different distances are given, or where the magnets or their spheres are unequal.

27. The conjunction of spheres is closest and most direct at the poles ; but between the poles is slighter and oblique. For at the poles the arrangement of the vorticles is rectilinear, but at every distance from the axis it is oblique; in which—oblique arrangement they nevertheless all have regard to the axis, upon which their union with the magnet depends. For the whole sphere is bound together, as by links, with the vorticles of the axis: if the vorticles out of the axis are moved from their own place to another, then, in consequence of their all being in series and connection, the vorticles in the line of the axis are also moved out of their place and drawn along with them ; consequently also, by their connection, those which are immediately conjoined with the magnet. Thus not only the motion, but the connection is also that of the whole sphere with the axis, and of the axis with the magnet; consequently the direct conjunction at the axis is the strongest and closest.

28. The greater part of the effluvia of iron or steel is magnetic ; but, in consequence of the irregular arrangement of the parts in iron or steel, there is no regular connection between the effluvia or vorticles ; consequently no sphere is formed by any regular arrangement of the parts ; nor can any magnetism be produced, before the vorticles with their effluvia, interiorly in the iron or steel, are reduced and disposed into a regular arrangement. That the magnetic effluvia are purely iron, penetrated and perforated at its formation by the magnetic element, we have already observed (art. 10): hence in the magnet there is nothing magnetic which is not iron, and there is nothing truly iron which is not magnetic. Hence a greater quantity of this effluvia surrounds iron, than surrounds the magnet. But inasmuch as magnetism consists in a perfectly regular arrangement of the parts, and a perfectly regular figure, into which the effluvia with its vorticles are adjusted, the iron possesses no magnetic force, unless at the same time it possesses a regular arrangement and figure of its smallest parts. For

when subjected to the melting heat of the furnace, or to the different changes as they cool, or to the frequent tremors and vibrations received from the hammer upon the anvil, the smallest parts are reduced to an irregular arrangement; and the consequence is, that there is no regular connection between the parts in the interior structure of the iron, nor any in its wall and boundaries, and consequently none with any surrounding sphere ; hence there are no poles, no equators, no relations of vortices, sphere Or figure to an axis; nor of the axis to this iron. In a word, none of the parts unite to produce any regularity ; hence the iron being surrounded by an irregular arrangement of effluvia, is rendered void of all magnetic power, inasmuch as the effluvia have no conjunction, by means of an axis, with the body or mass. If however the effluvia with its vortices, from any cause, are disposed into a regular arrangement interiorly in the structure of the iron, so that a regular conjunction is produced at its boundary and a disposition into a regular figure, in this case the iron is immediately invested with an attractive and magnetic power. On the figure of the sphere surrounding the iron, the reader is referred to chap. XII. of this Part.

29. If the effluvia of the iron approach the effluvia of the magnet, or the sphere of one approaches the sphere of the other, each sphere coalesces and unites into one that is larger; and the whole distance becomes an axis, the magnetism is thus rendered more powerful. This is evident from the causes alleged in art. 25. For two spheres by the approximation of their vortices and the application of their motions, combine into one, and extend themselves, like an axis, from one of the bodies, from which they are proceeding, to the other ; or, by means of a common axis, conjoin one magnet with another; and this the better, because a greater quantity of effluvia surrounds the iron than the magnet. Hence also it follows, that iron is conjoined with the magnet, or the magnet with the iron, by means of spheres ; that one invites and attracts the other, as it were, by a certain force ; and that they are



not repelled in different directions, as one magnet is by the similar or opposite pole of another; it follows also that the iron is conjoined with the magnet to the same extent to which the common sphere either penetrates or surrounds the iron 4 and that the whole mass of iron is conjoined with the magnet, provided the mass be penetrated or regularly surrounded ; unless its weight should be greater than the force of attraction exercised by the vorticles or sphere.

30. By the application and contact of the magnet and the iron, we observe that, in the structure of the iron, all the effluvia, which are perfectly or partially free, are disposed into a regular arrangement; and that the iron is thus rendered magnetic. The vorticles of the magnet which are next to the wall, as we have above observed, are most closely bound one to the other by the spirals which are closest together ; and are, as it were, folded into one another's embrace by planes possessing the greatest possible curvature. If the iron therefore is made to approach the magnet till it comes into contact with it, then the vorticles existing in each body are joined by the most curvilinear and rapid spirals ; consequently the vorticles which float in the iron freely, as it were, are reduced by a strong mechanical force to the same arrangement; and consequently

*Fig. 19.*

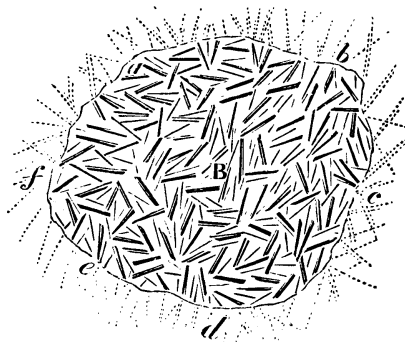

those also which flow without. Hence by means of friction, all the parts which are in a state of perfect or partial freedom,

are converted into such an arrangement, as to be able to form, with those which surround, a regular sphere and figure. It is for this reason that from a regular arrangement of the parts within the iron, magnetism exists; consequently poles and axes are formed ; and around the axes a regular figure or sphere, the circles of which, by their perpetual connection with one another, maintain a relation to the axis and the axis to the iron. Let us take the case of the effluvia in a rough piece of iron not yet rubbed by the magnet; the parts of which are arranged as represented in fig. 19, where we observe an irregular-connection extending round about to, a, Z>, c, d, e, f<sub>y</sub> and where one vorticle tends to the right, another to the left, and not one is connected harmoniously with another. In fig. 20 all the parts are in a rectilinear and parallel

Fig. 20.

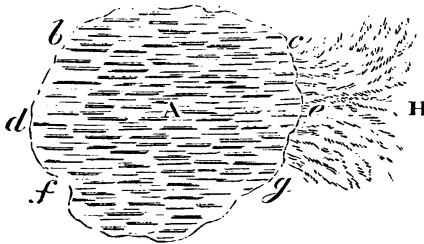

arrangement; hence at c, r, g, there is a regular conjunction and perfect aptitude for regularity of figure. Iron that has been rubbed is represented by fig. 21. For when the

Fig. 21.

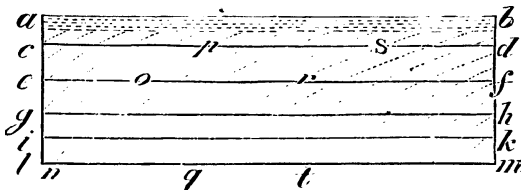

magnet is drawn from a to Z>, the effluvia seem to be reduced, from one extremity to another, into a parabolic or other regular figure; so that their arrangements are similar, as denoted by *Hop* and hence the effluvia without may be

regularly linked together with the effluvia within. Or if the friction takes place in the plane of the iron plate along its middle from C to D, then the effluvia are compelled to direct

Fig. 22. —

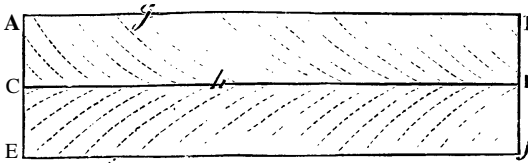

their course according to that of the friction, in order to have a constant relation as it were to the middle axis CD, and hence to unite toward the direction of the pole D. Or if the iron is too thick, as in fig. 23, and the force exerted in

Fig. 23.

~ \_\_\_\_\_ B

E L — ~

2 —

arranging the effluvia is not great enough to penetrate into the middle, still the effluvia occupying the surface may be adjusted on all sides into a regular arrangement; but since they have no connection with the interior effluvia, it follows that they return to their former irregular arrangement; the magnetism ceasing with the destruction of the regular arrangement. And because the magnetic sphere extends far beyond the iron to the other part of the magnet, it follows that, by the conjunction of their spheres, not only is the iron conjoined with the magnet, but also in a long connected series the iron with the iron ; the spheres of all the pieces of iron coalescing with the magnetic spheres into one. These observations are only general : in the sequel we shall proceed to particulars— and to actual experiment.

## CHAPTER II.

### THE ATTRACTIVE FORCES OF TWO OR MORE MAGNETS, AND THE RELATION OF THE FORCES TO THE DISTANCES.

#### A PRIORI, OR FROM FIRST PRINCIPLES.

There is no magnet absolutely the same as another, either as to its interior structure or as to the form of its surrounding sphere. Moreover the magnetism in the same stone is subject to variations arising from very varied causes. With regard to interior structure, there are some magnets exceedingly heavy, others lighter. There are those which are extremely full of effluvium ; others are almost destitute of it; there are those within which metals, minerals, and stones of different kinds are deposited, in greater or less abundance, by reason of which the connection as well as the regular and rectilinear flux of the smallest parts is disturbed ; there are others that are endowed with effluvia floating in a state of complete or partial freedom rather than in a state of union, and contrariwise ; others whose effluvia do not float from one wall to another, or from one pole to another, in a right line, but which are intersected by a regular or irregular curve from one end to the other, and in which the polar axes cannot be diametrically opposite to each other; there are those which possess interstices, partly rectilinear and partly curvilinear, passing through their structure; others which possess rectilinear ducts extending not to one but to several extremities of the magnet, and having a conical, triangular, or other form, so that not merely two but several poles, as it

were, originate; there are others which emit a great quantity of effluvia not in a state of 'due connection with the body. In the mass and figure of the magnet itself there is also diversity. In regard to 'their spheres, these spheres receive their form according to that of the magnet. If the magnet is spherical, it is surrounded with a sphere of a different figure from what it would have if it were elliptic, parabolic, cubic, parallelipedal, or otherwise angular; the sphere also varies in those different figures according as the polar axis lies parallel to the length or the breadth or obliquely at an angle. There are spheres which approach .very nearly to the circle or ellipse ; there are those which approximate to other curves ; others which, being in the closest connection with the body from which they are produced, enclose and, as it were, compress each pole with the most friendly embrace. There are those that abound with heterogeneous parts which hinder the free course of the motion ; for there are effluvia of innumerable kinds proceeding from all bodies. In a word, both with regard to internal structure and external sphere, there are indefinite varieties ; so that of these, as of all other entities much compounded, we may say that not one is absolutely the same as another. Hence arise such great and numerous varieties in the conjunctions and attractive forces of magnets; into this we propose to institute an experimental enquiry. To represent these differences by lines and figures would be to open a wide field of labour. Even in the same stone the mechanism cannot always be alike. There are large quantities of other effluvia, some of which may disturb or break the connections between the magnetic effluvia. The atmosphere itself is like a vehicle laden with effluvia. In the elements themselves, as in the ether, air, and fire, there are innumerable kinds of motions, which, in various modes and under various circumstances, may not only enter into the series and contiguous arrangement of the effluvia, but may also either relax or destroy the connection of some of the vorticles with the axis, and consequently with the magnet. There may be minute substances also

occupying the surface of the magnet, and intercepting its little openings and outlets, and preventing the effluvia from going forth or connecting themselves with the surrounding effluvia. To enter into these particulars and 'to assign the laws according to which these effluvia act, would be a task of considerable labour; nor do I know that it would be of much use, unless we could also furnish the figures and the mechanism of the several parts.

2. The attractive force or conjunction of two or more magnets or pieces of iron, depends not only upon the axis but upon the whole surrounding sphere. The polar axes are formed by the figure of the sphere, as we have above stated ; and from the polar axis on one side, the vorticles and elementary particles bend their course and proceed circuitously to the axis on the opposite side ; and from this axis to the polar side or margin of the magnet. There is consequently a connection of the whole sphere with the axis, and of the axis with the magnetic body ; and all the effluvia with their vorticles form a series and contiguous whole; therefore the motion of the one is the same as the motion of the other; the motion of the parts in the equator is the same as the motion of the parts in the axis ; there is thus between all a coherence which can be obtained only by regularity of figure. Magnets, therefore, which have their two spheres mutually conjoined, and which, as it were, draw and invite each other by their attraction, not only are conjoined, or drawn together by the axis, or directly, but also are sensible of the force and attraction throughout their whole sphere ; nor can they be separated from each other except by the consent of the entire sphere surrounding the magnetic body. For if the vorticles cohere in one series, and if by this coherence a regular contiguous whole be formed, then are the force and motion of one the same as the force and motion of another and of all collectively, or of the contiguous whole. Thus the attractive force depends principally upon the perfect regularity of the figure of the sphere.

3. The attractive force between magnets is strongest at a small distance, weaker at a greater ; and none in the place where the spires of the vorticles begin to embrace one another at an angle of forty-five degrees. We have shown above, that the force of attraction is stronger at a smaller distance from the magnet than at a greater. Thus in fig. 18 (p. 262), A and B are two magnets; the distance between them is BA : in this case the vorticles reciprocally comprehend and unite with one another at a greater distance, thus with spires of less curvature; hence the connection of these magnets is according to that of the vorticles or spires in *ab*. In fig. 15 (p. 261), the union of the magnets is according to the union or conjunction in *ab*, where they combine more intimately with their spirals; and still more so in fig. 14 (p. 261), at *ab*. The connections cannot exist except in the line or plane of conjunction, which is the cardinal plane of each sphere. If the magnets are unequal in weight, mass, sphere, and force, then the cardinal plane cannot be at the middle, but will be situated as in *ab* fig. 17 (p. 262), or *ab* fig. 18 (p. 262), where its distance to B is greater than it is to A; because the sphere of one is larger than the sphere of the other, and consequently extends its axis to a greater distance. The fact of the conjunction of the spheres being similar to that of the effluvia in the plane *ab*, follows from mechanical principles. For suppose a rope whose strands are strongly twisted together to pass over a pulley ; and that half-way between its extremities it happens to be smaller or thinner; in this case the strength of the whole rope depends upon the strength of this particular part. Where the coherence is less, the strength of the rope is less; and upon this part the entire contiguous length is dependent. Not only, however, does the conjunction of the spheres depend upon the intermediate connection in *ab*, but upon the entire surrounding sphere; because the connection itself, formed by the coalition and conjunction in *ab*, coheres with the connected whole.

## ATTRACTIVE FORCES OF MAGNETS.

That the mechanical connection of the motions does not extend beyond an angle of forty-five degrees in the spiral planes, may be seen in fig. 24,

Fig. 24.

where the spiral of greatest curvature is *ac*; of lesser curvature, *elf*; of

\

• \ • X : still less, »<sup>and</sup> approximating still

*I c c f ft, i Z ih* nearer  $t_0$  a right line in *km*. If the side *be* be less than the side *ba*, then there is a mutual connection of the spiral planes ; but if the side *Im* be greater than the side *Ik*, then there is no such connection ; that is to say, if the angle *Ikm* is more than forty-five degrees; for in this case the spiral bends itself from the cardinal plane toward the position of a right line more from *I* to *m* than from *m* to *I* or to conjunction; as may be illustrated experimentally by screws, helices, or polished planes joined together at various angles. For the connecting forces tend to *I'm* more than they do to *Ik*; that is to say, more to a separation than to union. Hence if in fig. 16 (p. 262) the vorticles are conjoined in their place of coalescence or cardinal plane *ctb*, at an angle of forty-five degrees, they cannot present any farther force of union beyond this; for from this distance the whole attractive force between the two magnets ceases. The fact of the magnet being able to turn the needle towards itself at a still greater distance, such as one of several ells or even ten feet, does not arise from the connecting and attractive force of the sphere ; for the needle, when touched with the magnet, will obey any angularity of spiral. On this subject, however, we shall speak in the sequel.

4. There cannot be two magnets possessing the same attractive force. But in magnets perfectly similar, there is always a constant geometric relation between the attractive forces and the distances. They cannot possess the same attractive force, because no two magnets can be alike as to their interior structure or exterior sphere. But supposing two could be perfectly alike, and possess precisely the same force, then



there would be a constant geometrical ratio between the attractive forces and the distances. For the figure of the sphere is regular ; there is a regular progression of the vorticles and spiral motions along the axis ; consequently there is a constant geometrical ratio of forces according to the distances, a ratio which is an ordinary geometrical one. But since the attractive force depends upon the spheres and the figure, and there is no one sphere exactly the same as another, nor at all times the same as itself; it follows that we cannot assign any constant ratio of attraction between any two magnets. Moreover, if any two magnets decline in the least from a perpendicular position, or from a direct opposition to each other, there immediately arises a difference in the relation between the attractive forces and the distances; as in fig. 25. If the position of the magnet *a*,

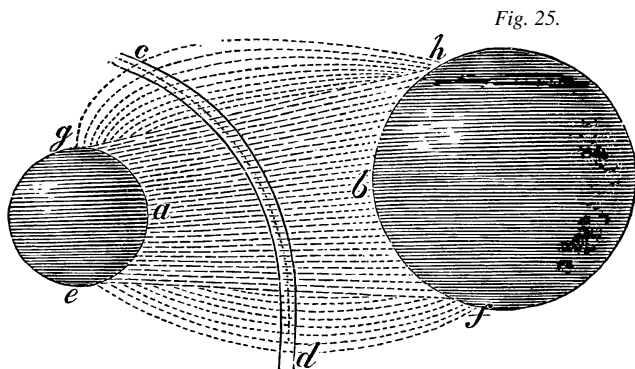

in regard to the position of the magnet *b*, be not direct but oblique, there will result a different intervening axis; consequently a different figure of the sphere, and thus a different attractive force. Hence a perfectly exact ratio between the forces and distances cannot in this case be expected. But let us proceed to experiment.

## THE SAME ARGUED A POSTERIORI OR FROM EXPERIMENTS.

There are no experiments with the magnet more convenient and suitable for our purpose, than those which have

Fig. 26.

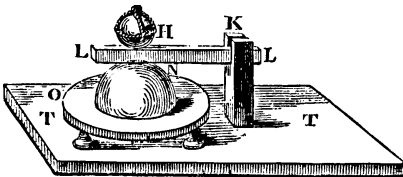
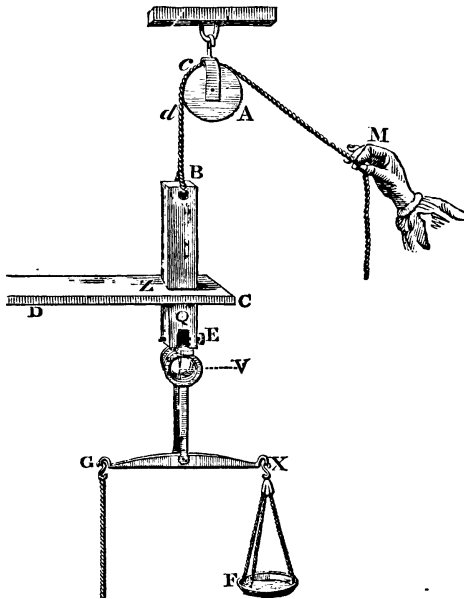

been lately given to the world by the very learned and sagacious Pieter van Musschenbroek;<sup>x</sup> who has been so

<sup>1</sup> In *Physical Experimentales et Geometrical*. Lugduni Batavorum, 1729.—Trs.

ingenious in the mode of conducting his experiments. In examining, therefore, the phenomena of the magnet, and comparing them with the principles we have already laid down, I shall quote the words of this highly experienced author.

“ *I took,*” says he, “ an extremely accurate balance, XG (fig. 26), the axis of which was exceedingly fine and polished, so that the beam XG could turn on it with the greatest freedom, and be depressed at either end X or G by putting in the twentieth part of a grain. In order, moreover, to make the slightest depression visible, the pointer of the beam was made to end in a very fine point, and directly opposite to it, a little pin V projected downward from the middle of the upper part, between the side bars within which the pointer moves. These bars being here expanded into rings, left an opening through which one might see whether the pointer kept exactly opposite the pin, or inclined to one side or the other; as also the deviation on either side ; in other words, it might be seen whether there was equilibrium or not. To the end G, I attached a cord GH, several feet long, which was wound round a spherical magnet H, called by philosophers a *terrella*. This length of cord was requisite in order to prevent the magnet H acting upon the beam GX, which was made of steel. From the other end of the beam, X, was hung a copper scale F, for holding weights, to measure the attractive forces of the magnets.

“ Our object being to ascertain the forces of the magnets placed at various distances from each other, it was necessary that we should be able to raise or lower the beam of the balance ; and in order that the magnet, hung from the beam, should always keep directly opposite the same point of the upper surface of the fixed magnet placed underneath, it was requisite that the beam should be so raised, that its centre should be always in the same straight line, perpendicular to the horizon. For this purpose I inserted the hook Q at the top, into a notch cut into the wooden block QB, in which I

fastened it by the pin E. I then passed the block QB through a square hole Z cut out of the support DC, which was fixed firmly into the wall, so that I could raise or lower the balance together with the block BQ, just as I pleased ; and in order to do this with perfect ease I attached to the block the cord B<sup>^</sup>cM, which passed over a wheel A. Had the beam been hung solely by a cord, it might have been constantly turning round in consequence of the latter twisting or untwisting according to the dryness or dampness of the weather; so that without the foregoing arrangement I could not have ventured upon making any observations. The other magnet which was to be operated on by the former H, was the sphere NO, placed on a round piece of board,, hollowed out in the middle, so that the magnet NO might be the more easily placed in any required position. This piece of board, to which three legs were attached, stood upon a strong table of wood TT, which was without iron nails or iron at all, lest it should interfere with the reciprocal action of the magnets.

“ Having completed the apparatus, I ascertained the weight of the magnet H, and of the cord GH, having first removed the other magnet NO from its table. From the hook G was then hung a length of fine cord, in order to mark the point which stood immediately under the end G of the beam ; at this point I placed the pole of the magnet NO. I then placed both the magnets in such a position that their axes, or lines passing through their poles, might stand at right angles to the horizon, and in one and the same straight line. The lower pole of the magnet H attracted the south pole of the magnetic needle ; the upper pole of the magnet N attracted the north pole of the needle; consequently the two poles of the magnets now facing each other were mutually attractive. On first commencing the experiments, I raised the magnet H to a considerable height above the lower magnet N, and then established equilibrium by placing a weight in the scale F. Then slackening a little the rope

UlcdR, I let down the magnet H to certain shorter distances from N ; and when, by reason of the attraction between the two, the former began to fall, so as to lose the equilibrium produced by the weight in the scale F, I restored the latter by gently adding, so as to avoid concussion, other small weights which indicated the amounts of the magnetic forces at the several distances. The larger distances I measured with a scale made entirely of brass ; and by these means I could easily ascertain the attractive forces at the various distances. When, however, I came to take note of the forces at smaller distances, it was difficult to determine the different points of equilibrium ; for if the weight at F was not heavy enough, then the magnet H approached too closely to the magnet N; on the other hand, if the weight at F was a little too heavy, then the magnet H ascended too far. To obviate this inconvenience, I took some plates of brass LL, or S as

27

s

s<sub>0</sub>HHS<sup>s</sup>ej J

s

curej

marked in fig. 27, varying from one another in thickness the twelfth of an inch ; of these I provided myself with twelve. I then procured others, one of which was in thickness the *ft* of an inch, another A, another *t*s. Then placing one of the plates upon the pole of the magnet NO, and making it fast in the notch cut into a piece of wood K, the upper magnet was lowered, until its pole came in contact with the plate, and the pointer of the balance stood opposite the little pin V; in this way I could ascertain the exact distance between the magnets. I then placed other small weights, which were apothecaries' measure, in the scale F, until the magnet H was raised by overcoming the attractive force. To prevent any mistake, I always performed the experiment twice, placing my weights in the scale one by one with the utmost care ; because had a weight been thrown into the scale from too great a height, or had I put in two together, the magnet H would have been raised too rapidly, and the true attraction at a given distance could not have been obtained. Moreover for making my experiments, I selected

the days which were fine and without wind ; for as often as the air became agitated by wind, our very sensitive balance was never at rest ; so that we could not secure a balance, even when the apparatus was moved to a cellar; for the external air always communicated its motion to the air inside the house.

“ In order to omit nothing which might affect the experiment, I took note of the day of the year, the height of the barometer and thermometer, the dryness of the atmosphere, and the quarter of the wind. These particulars I afterwards found were not without their use; for I discovered in consequence that the forces of the same magnets vary at different seasons of the year, and therefore that in experiments of this kind the season ought always to be taken into account.

“ In this description of the method of making our experiments, I have been rather diffuse; but the reader is hereby enabled to satisfy himself whether they have been made with proper care. At all events, if any error has crept into our experiments, as is generally the case where many are performed, it can only be a small one, and can scarcely amount to more than a grain or two.

“ To be as concise as possible, I have arranged all the results in a table. The following are those which I obtained on July 10, 1725, when the barometer stood at 29 A Rhenish<sup>1</sup> inches, and Fahrenheit's mercury thermometer stood in the sun at 61| ; the weather being damp and rainy and a light west wind blowing. The two magnets employed were two spherical ones, the diameter of ON being 6 j inches, and of H, 1| inches.

<sup>1</sup> Rhenolandicos—*Ryrland or Leyden*.—Trs.

MUSSCHENBROEK'S EXPERIMENTS.

“EXPERIMENT I.

Distances of Magnets. Inches.	Magnets. Lines.	Attractions measured by- Apothecaries’ Grains.	Distances of Magnets. Lines.	Attractions measured by- Apothecaries* Grains.
5 ...	. 10	= 11	6	= 38J
4 ...	. 6	= 21	5	= 43}
3 ...	. 9	= 3	4	= 50}
2 ...	. 4	= 9	$\frac{n}{o}$	= 62
1 ...	. 9	= 12	2	= 79
	12	= 23	1 <sup>3</sup>	= 81
	11	= 23J	1	= 140
	10	= 26}	1	= 186 '}
	9	= 29	$\frac{1}{3}$	= 240
	8	= 30}	0	= 340
	7	= 33		

“From these experiments we derive the following corollaries :—

“ *Cor.* 1. Two magnets attract each other at different distances with different forces, and the nearer they are to each other the greater is the force of their attraction ; consequently it is greatest when the magnets are in contact. For when they were in contact, the force of attraction was equal to the weight of 340 grains, while at the distance of twelve lines the force equalled only 23 grains.

“ *Cor.* 2. From an examination of the foregoing experiments it appears that the attracting forces were not in so great a ratio as the inverse ratio of the distances; but that the ratio was less. For when the attractive force was at the distance of half a line, it was equal to 186 grains; at double the distance or one line, it was equal to 140 grains ; whereas had it been in the inverse ratio of the distances, we should have had the weights which follow :—

Distances of Magnets. Lines.	Calculated Weights.	Observed Weights.
J	186 .....	186
' 1	93 .....	140
2 =	461 .....	79
4	23J .....	50J
8	IIf.....	30

“ If again we fix upon other distances, we equally find the real attractions to be greater than the previous calculation indicates.

Distances of Magnets. Lines.	Calculated Weights.	Observed Weights.
i	240 .....	240
1	80 .....	140
3	26 .....	62
9	81 .....	29
27	3 almost....	9

“ *Cor.* 3. If we now attend to the proportion of the attracting forces, we by no means find it to be constant; for at J line distance the weight was 186 grains; and this number is to 140 grains as 111 to 1; a proportion which would always obtain in the other following numbers, supposing the ratio to be constant. But  $140 : 79 :: 111 : 1$ . Also  $79 : 50J :: 1At : 1$ . And  $50J : 33 :: ill : 1$ .

“ In all these cases, however, the real proportion is different from the foregoing. Now since innumerable proportions may be deduced, I have taken no little pains to discover from the given numbers one regular proportion either simple or compound ; but hitherto they have been fruitless.

#### “ EXPERIMENT II.

“ Being however unwilling to rely solely upon experiments made with the foregoing magnets, I entertained a hope that I might perhaps make some further discovery by the use of other magnets. For it seemed to be possible that some foreign substance either in one or the other might operate to produce



a less accurate and constant proportion between the attracting forces and the distances. I consequently left the same large spherical magnet NO in its place on the table; but from the beam GX was hung another magnet, naked or unarmed (such as is used in making experiments). The form of this magnet was that of a block, 2 inches deep, 2½ long, 1½ wide. This magnet I hung up, so that both poles were in a line at right angles to the horizon; and also in the same line with the two poles of the other magnet. The experiments thus conducted furnished the subjoined results.

“ The experiments were made on July 11, 1725, when the barometer was at 29.4 inches, and Fahrenheit’s thermometer at 62°; a wind blowing from the north and the weather being dry and fair.

Distances of Magnets.		Attractions measured by Apothecaries’ Grains.	Distances of Magnets.		Attractions measured by Apothecaries’ Grains.
Inches.	Lines.		Inches.	Lines.	
12	.. 0	= 0	7	= 106	
9	.. 0	= 1}	6	= 111	
8	.. 0	= 1}	5	= 132	
7	.. 6	= 2	4	= 149	
7	.. 0	= 21	3	= 173	
	12	= 701	2	= 205	
	11	= 751	1	= 240	
	10	= 85	i	= 270	
	9	= 92	0	= 300	
	8	= 100			

“EXPERIMENT III.

“ It appeared to be desirable to ascertain, whether the attractive forces of the same magnet were equally strong at all times; whether the changes of heat and cold produced any variations; whether the forces of the magnet in winter were different from what they were observed to be in summer. With this view I repeated my determinations of the magnetic forces on the 24th day of December in the same year; using

the same magnets and the same apparatus as before. The results were as follows :—

Distances of Magnets.		Attractions measured by Apothecariss' Grains.	Distances of Magnets.		Attractions measured by Apothecariss' Grains.
Inches.	Lines.		Inches.	Lines.	
15 ....	6	= 0		9	= 94
13 ....	6	= 0		8	= 106
12 ....	0 scarcely	= $2\frac{1}{T}$		7	= 114
11 ....	0	" = J		6	= 131
10 ....	0	" = I		5	= 146
9 ....	0	= i		4	= 172
7 ....	6	= li		3	= 190
7 ....	0	= 2i		2	= 215
	12	= TOj		1	= 250
	11	= 78J		i	= 290
	10	= 87		0	= 340

“Thus we found, that when the magnets were in direct contact, the attracting forces were the same ; as was also the case when the spherical magnet H was in direct contact with the spherical magnet NO. But when the magnets were at the same distances from each other as were indicated in the former table, a great difference was observable between the attractions; we remarked also that the attractions were not in the inverse ratio of the distances, but in a less ratio; likewise, that the attractions did not increase or diminish in any constant proportion as the distances increased or diminished.

“Thus in our second experiment, the ratio of the forces at the same distances we found to be as follows :—

Distances.	Forces.	Proportion.
i	= 270	<b>li : 1</b>
1	= 240	<b>1A : 1</b>
2	= 205	<b>It A : 1</b>
4	= 149	<b>It A : 1</b>
8	= 100	

“ But in our third experiment the ratio of the forces at the same distances was as follows :—

Distances.	Forces.	Proportion.
I	290	:: It ? : 1
1	250	:: It ? • 1
2	215	:: It t 2 : 1
4	172	:: $\frac{1}{153}^{33}$ : 1
8	106	

“ Hence it is evident that there is not the same proportion of the attractive forces in winter as there is in summer, if we compare the ratios determined by the two experiments.

“EXPERIMENT IV.

“ In addition to the foregoing experiments, I took two other magnets, each of which was in the form of a block. Of these I hung one from the beam GX, the other I placed upon the table TT, taking as much care as I could that both the < polar axes should be in a line at right angles to the horizon. The size of one magnet was as follows; in length 2| inches, breadth 2J inches, thickness 1} inches; the size of the other magnet was, in thickness 2 inches, length 2} inches, breadth 1^ . The results of the experiments made with these two magnets are as follows :—

Distances in Inches <fc Lines.	Attractions measured by Apothecaries' Grains.	Distances in Inches <fc Lines.	Attractions measured by Apothecaries' Grains.
9. ... 4	0 3	... 11	4}
8 .... 6	1	3 ... 1	U
7 ... 9	1	2 ... 5	12}
7 ... 3	1	1 ... 8	21}
6 ....5	1	10	45
5.. .11	2}	5	95
4.. .11	2}	0	128

“ These experiments lead to no other conclusion concerning the ratio of the magnetic forces than is derived from the previous ones.

“ EXPERIMENT V.

“I next took the large round magnet NO, the diameter of which was 6 J inches, and which I had used in experiments I., 11., in. This I placed upon the table TT, upon which it was firmly fixed, and from the beam I hung the block magnet, which I had used in experiment iv., and which was in length 2} inches, breadth 2 J, and thickness 1|. In this case the forces of attraction were observed to be as follows :—

Distances in Inches & Lines.	=	Attractions measured by Apothecaries' Grains.
19 . . . 0	=	0
18 . . . 0	=	1
17. . . 4	=	1  The weight was the same at various other distances.
13 . ... 0	=	2 The weight was the same at various other distances.

Distances in Inches & Lines.	=	Attractions measured by Apothecaries' Grains.		Distances in Inches & Lines.	=	Attractions measured by Apothecaries' Grains.
9.... 9	=	21		4	=	209
10	—	122		3	=	218
8	=	136		2	=	241
7	=	164		1	=	273
6	=	170		0	=	340
5	=	187				

“ From the foregoing results it is again evident, that there is no constant ratio between the forces and the distances; for the actions of these magnets were not in the simple inverse ratio of the distances, inasmuch as at the distance of 1 line, the action equalled 273 grains, and at 2 lines the attraction equalled 241 grains.

“ If the actions were in the inverse ratio of the distances, then at the distance of 2 lines the weight required to counterpoise the attraction would be 136 J grains, or the half of 273.

“ Now the forces themselves are in the proportion of  $1^{\wedge 3} \frac{2}{T}$

to 1, and if they continued in the same proportion, decreasing as the distances increased, then at the distance of 4 lines, they would equal  $212\frac{1}{4}$  grains. But the experiment shows that they equalled 209 grains, consequently the computation does not correspond to the observations. It would in like manner be easy to show that the results of other experiments were equally far from exhibiting any constant proportion between the forces and the distances, use what mode of computation we might.

“ Indeed the same fact has been remarked by the celebrated Taylor, who from his experiments concludes that the magnetic forces did not correspond to the distances, but that the proportions experienced a decrease which was greater at the larger distances than at the smaller. The same conclusion may also be derived from my own experiments. This philosopher, however, has added, that in the experiments which he made with two needles at a distance of 2 J inches, the forces did not vary in a ratio as great as the squares of the distances, and that at a distance of 10 inches the forces varied more than as the cubes of the distances, when the exponent was 3. See *Philosophical Transactions*, vol. xxxi., p. 204.

“ From these five experiments we learn nevertheless, 1. That the actions of two magnets upon each other do not exist at every point of distance, but that the distance of their action is determinate; for in experiment iv. it did not extend as far as 10 inches, nor in experiment v. as far as 19 inches; at least our highly sensitive balance did not indicate any evidence of their action. Consequently were I to reason solely from these experiments, I could not infer that the actions of magnets extended to very considerable distances. From other experiments however which were made with extremely sensitive needles, it was evident that the magnets acted upon them at much greater distances than could be observed by the adoption of the former method, inasmuch as the needle turned upon its pivot with far less friction than the beam upon its axis. Still from the action of the magnet

upon the needles we might notwithstanding draw the same inference as in the former case, inasmuch as even the needles at a distance of several feet were not set in motion by the magnet, for I never found the action of the magnet extend beyond 14 Rhenish feet, when to a needle six inches long I presented a most excellent magnet.

“ 2. *If we compare these five experiments with one another, we may observe that the forces of the several magnets did not extend to the same distance; but some to a larger, others to a smaller distance. Thus in experiment v. it extended to 18 inches, in experiment iv. to 9 inches, in experiment III. to 13 inches, in experiment II. to 12 inches. Nay, I had a large magnet, the action of which was sensible at a distance of 11 feet, and sometimes at a distance of 14 feet.*

“ 3. Moreover, although in experiments I., II., V., we observed that the attractive forces of the magnets at equal linear distances were very different; that in the fifth experiment they were greater than in the third; and in the third greater than in the first; still it is surprising that when the magnets were in immediate contact their forces were the same, being equal to 340 grains; and this is the more surprising, when we consider that the magnets suspended from the beam, and which we had employed in three of the forementioned experiments, were unequal in volume, and different in weight and form ; when we consider also that the forces of these magnets differed exceedingly from one another; for the best magnet, although small, was the round one employed in the first experiment, while the forces of the magnet employed in the fifth experiment were only moderate, but those of the magnet employed in the third experiment were exceedingly feeble. Besides in the first experiment one globe was in contact with another globe, in the third and fifth one globe was in contact with a plane surface. It is true that in all three cases the contact was at one point, but beyond this point of contact the two spherical surfaces receded more from

each other, than the spherical from the plane surface. On a consideration of these circumstances, I began to doubt whether the action of magnets depended upon any magnetic effluvia, or any external fluid, call it by what name we may—a----- subject to which I afterwards gave further attention. For if the action of two magnets depended upon their mutual effluvia, then would their action be greater in proportion to the greater quantity of effluvia, and this quantity would flow in a much greater degree from the more than from the less replete magnets, consequently a much greater quantity of effluvia would have proceeded from the magnets which I used in the first and fifth experiments, because these excelled the one employed in the third experiment. In direct contact, however, the forces of all the magnets were observed to be equal." (*Op. cit.*, pp. 13-24.)

## CHAPTER III.

### THE ATTRACTIVE FORCES OF TWO MAGNETS WHEN THEIR POLES ARE ALTERNATED.

#### A PRIORI OR FROM FIRST PRINCIPLES.

The magnetic sphere about one pole is not similar to the one about the other pole, nor is the axis at the south pole extended similarly to that at the north pole ; but in the figure of the sphere there is always a difference on each side ; consequently there is not exerted the same force at each pole ; nor is the attractive force of two magnets the same if the poles are alternated, that is to say, if the ends of the magnets are inverted, and homogeneous poles are opposed to each other. Thus let A be

*Fig. 28.*

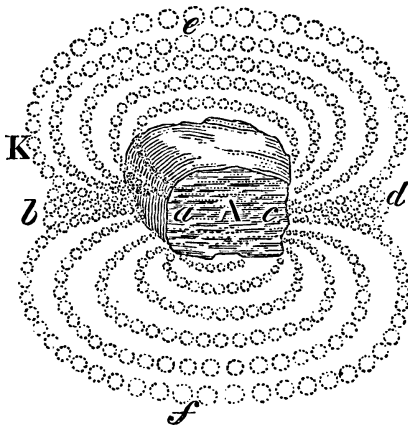

the magnet, *c* its north pole, *cd* the northern axis of its sphere, *a* the south pole, *ab* the southern axis. We affirm that on



the side the figure of the sphere or the extension of the axis is not always either the same as or similar to that on the other side *ab* ; and consequently that the force about one pole is either greater or less than the force about the other, and contrariwise. For suppose that the stone is magnetic only on one side; that on this side only its pores are rectilinear ; that on one side it is more impregnated with effluvia than on the other; in this case, its figure on one side is different from what it is on the other; hence the sphere, which arises and is formed out of the nature and form of the magnet, generates on one side an axis larger and stronger than the axis on the other. Consequently there is no magnet possessing on one side a force and figure of sphere exactly like that on the other ; hence neither is the attractive force of two magnets alike if their poles are alternated or inverted.

#### MUSCHENBROEK'S EXPERIMENTS.

Muschenbroek, who was so highly skilled in conducting magnetic experiments, thus continues. He says :—

“ Hitherto, I had been examining the attractions of the two poles in both magnets ; but I thought it desirable to ascertain whether the obverse poles exercised the same, or different attractive forces from those which were exerted in the former case.

#### “ EXPERIMENT VI.

“ I therefore again hung from the beam by a cord, the small spherical magnet H, which I had employed in the first experiment, but so that the other pole now hung downwards. I next placed upon the table TT as before the larger spherical magnet NO, whose other pole in the present case was turned upwards, both poles being placed in the same line at right

angles to the horizon ; and having taken all the precautions mentioned in the previous chapter, I observed the mutual attractions of the magnets, at the different distances mentioned before; the date of the observations being July 12, a.d. 1725.

Distances in Inches and Lines.		Attractions measured by Apothecaries' Grains.	Distances in Inches and Lines.		Attractions measured by Apothecaries' Grains.	
4 .	.. 6	=	It	7	=	39
4 .	2	=		6	=	44
3 .	.. 9	=	21	5	=	48
2 .	.. 4	=	9	4	=	59
1 .	.. 9	=	12	3	=	68
	12	=	26	2	=	89
	11	=	28	1	=	132
	10	=	31	1	=	155
	9	=	34	J	=	225
	8	=•	36	0	=	310

“ Now if we compare these forces with the others I described above, we shall perceive a great difference between them and observe that in all these instances the forces are less than in the former. Consequently the two poles of a magnet do not exert upon another magnet the same forces of attraction, but different ones.

#### “ EXPERIMENTS VII. AND VIII.

“As I possibly might have been too hasty in my conclusions had I trusted to a single experiment only, I made many experiments. Consequently the large round magnet ON which I had used in experiments L, II., v., I fixed on the table, and a different magnet from the one I had hitherto used I hung from the beam, on Feb. 17, 1726. The poles which mutually attracted each other I placed obversely to each other, so that I might be able to note the equality or inequality of the attractions. The following are the results in each case; I have put them together in the following order

that the eye may the more easily see at a single glance the diversity of the forces at the same distance.

“ EXPERIMENT VII.

EXPERIMENT VIII.

Distances in Lines between the first two Attracting Poles.		Attractions measured by- Apothecaries' Grains.	Distances in Lines between the first two • Attracting Poles.		Attractions measured by- Apothecaries Grains.
12	=	57	12	=	72
11	=	63	11	=	78
10	=	66	10	=	87
9	=	70	9	=	94
8	=	79	8	=	106
7	=	83	7		114
6	=	90	6	=	131
5	=	101	5	=	146
4	=	113	4		172
3	=	124	3	=	190
2	=	148	2	=	215
1		168	1	=	205
0	=	228	0	=	340

(*Op. cit.*, pp. 24-26.)

## CHAPTER IV.

THE ATTRACTIVE FORCES OF TWO MAGNETS WHEN THEIR AXES ARE PARALLEL, OR WHEN THE EQUINOCTIAL OF THE ONE LIES UPON THE EQUINOCTIAL OF THE OTHER.

### A PRIORI OR FROM FIRST PRINCIPLES.

When two or more magnets are so placed that the equinoctial of one lies upon the equinoctial of the other, the spheres of the two magnets combine into one that is larger and form a certain large axis between the poles of the magnets. By placing together two or more magnets, the spheres are mechanically compelled to bring their motions into a state of harmony or equilibrium. For similar parts could not subsist together and be put in motion in one and the same volume, unless the motion of one part accommodated itself to the motion of the other ; for of two spirals near each other one cannot flow in a direction contrary to the other, one helix cannot turn in a direction opposite to that of the other. Nature rejects and resists motions dissimilar, contrary, and heterogeneous, because she is mechanical. In one and the same volume her concords are nowhere discordant; nor can any one equilibrium be opposed to itself; for even could this be the case, it must by the very motion and mechanism of nature be immediately rendered concordant and harmonious. In the present case, since the motions are purely and highly mechanical, and together with the motion, also the forces and powers, in each vorticle, at any distance or spiral from the centre; it follows that when the two spheres are brought together they must unite in a way which agrees with the figure and mechanism of the parts or vorticles; and consequently the vorticles conjoin themselves according to the representation in fig. 29 : that is to say, in such a manner

that one sphere arises out of two, conjoined to each other by their poles or axes.

But the spheres of two or more magnets are, as to the poles, mechanically so conjoined according to the motion of the vortices, that in the middle distance between the magnets the vortices are situated parallel to the axes of the magnets ; but at the sides they are perpendicular to the axes; and consequently between the middle and extreme distance, they are in a position oblique to the axes. Thus in fig. 29, all the vortices, or, to-

Fig. 29.

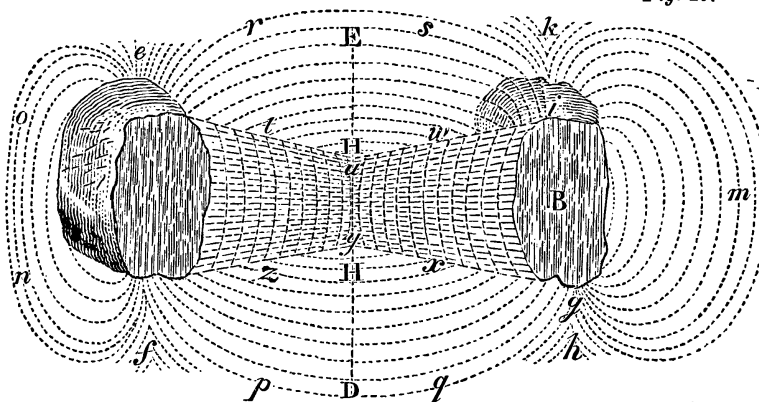

gether with them, all the elementary particles, are in a position parallel to the polar axes of each magnet in  $stf$ ,  $HH$ ,  $xw$ , but at either side they are in a position perpendicular to these axes, such as  $ersk$  or  $fpDq$ . So also in the intermediate distance they are in a position oblique to the axes ; for all the vortices lie upon the equinoctial of the magnet, in a position parallel with the axes ; and those which spread out along the axis, are, with respect to the former, perpendicular; and cannot be mechanically brought into equilibrium, unless the axis of each one vortex is applied to the axis of the other and conjoined with it ; the same must take place with regard to the equator, in which case, and thus in intermediate positions, they gradually curve themselves obliquely from the parallel into the perpendicular position.

2. Two or more magnets, placed in a position in which their axes are parallel, or in which they lie in the direction of their equators, possess in like manner a conjunctive force ; but yet not at the same distance as when they are conjoined by the mutual application of their axes or poles. 'For if one pole be conjoined to another, by the position and motion of the vorticles extending from *e* to H, or from *f* to *gh*, there follows the conjunction of the two magnets. But in the middle distance at *yu* or HH, there is no conjunction between them ; because here all the motions are parallel, possessing neither an attractive nor a repelling force, therefore they conduce in no respect to a state of conjunction ; the motions which contribute to this result are solely those which are perpendicular, such as those from *e* to *ki*, or from *f* to *gh*, etc.; by means of which there is a binding of one magnet to the other. Therefore magnets placed in the forementioned position, at so great a distance, cease to be attractive; just as is the case if one axis be placed opposite to the other. But the result is different if the spheres be brought together in the direction of the equators, so that poles of the same name are turned the same way.

musschenbroek's experiments.

"EXPERIMENTS IX. X. XI. XII.

" Not relying, however, solely upon the experiments made with the magnets under the foregoing circumstances, namely, having both their poles placed opposite each other and in one and the same line, I wished to ascertain the quality and quantity of the attractions when the magnets were placed opposite each other in a different manner, namely, when their axes were placed parallel to each other or at right angles; not indeed that I hoped to discover much from these arrangements, or that I should throw much further light upon the laws of magnetism ; but because in the physical sciences we sometimes discover more by accident than by foresight; so

that in order to omit nothing relative to this method of examination, I made preparation to pursue my experiments. The large round magnet which I had used in the two preceding experiments, I fixed, as before, upon the table, in such a position, that the line joining the poles was perpendicular to the horizon, as in the preceding cases; but the magnet having the form of a block and which I had used in some of the foregoing experiments, I hung from the beam in such a way that the line joining the poles was parallel to the horizon. Now this block having six polar sides, two of which had already been examined, there remained four others for investigation. I therefore first examined two of the sides which were opposite and parallel to each other, then in like manner the other two ; and I noted the following results which I exhibit in two tables.

“The two opposite sides of the magnet, when made successively to face the same pole of the round magnet, exhibited forces of attraction at the several distances as follows:—

“EXPERIMENT IX.			EXPERIMENT X.		
Lines.		Attractions measured by Apothecaries’ Grains.	Lines.		Attractions measured by Apothecaries’ Grains.
12	=	32	12	=	32
11	=	34	11	=	34
10	=	32	10	=	37
9	=	34	9	—	40
8	=	38	8	=	46
7	=	43	7	=	52
6	=	48	6	=	56
5	=	56	5	=	69
4	=	63	4	=	76
3	=	74	3	=	94
2	=	94	2	=	115
1	=	114	1	=	146
0	=	178	0	=	196

“ The two other sides of this magnet placed opposite the pole of the round magnet exhibited the forces at the several distances as follows :—

“EXPERIMENT XI.			EXPERIMENT XII.		
Lines.		Attractions measured by Apothecaries’ Grains.	Lines.		Attractions measured by Apothecaries’ Grains.
12	=	20	12	=	13
11	=	20	11	=	13
10	=	24	10	=	16
9	=	25	9	=	16
8	=	29	8	=	21
7	=	34	7	=	24
6	=	36	6	=	28
5	=	44	5	=	34
4	=	51	4	=	39
3	=	59	3	=	51
2	=	73	2	=	63
1	=	93	1	=	83
0	—	135	0	=	128

“ How great is the variation between the attractions of these four sides ! Yet if the substance of the magnet were homogeneous, and if the axis of the poles lay midway between the two surfaces of the block, ought not the attractions of the four sides to have been equal ? I see no reason why they should not: and yet the magnet I used in the investigation seemed arranged in this way; but whether very accurately so I confess I had no means of ascertaining. It is certain however that the observations exhibiting the measures of the several forces, differ very much from one another.”  
(*Op. cit.*, pp. 26-28.)



## CHAPTER V.

THE DISJUNCTIVE AND REPULSIVE FORCES OF TWO OR MORE  
MAGNETS WHEN OPPOSITE POLES, OR THOSE OF THE  
SAME NAME, ARE APPLIED TO EACH OTHER.

### A PRIORI OR FROM FIRST PRINCIPLES.

If two or more magnets are so applied to each other, that, the south pole of one is opposed to the south pole of another, or the north pole of one to the north pole of another, that is, if two poles of the same name are opposed to each other at different distances, then the spheres of each magnet will coalesce into one large sphere. The individual parts or vorticles of each sphere are like one another; and if the spheres be applied to one another, they must, like two volumes, coalesce and combine into one. The individual parts are the vorticles, which form the sphere solely by their own spiral motion; therefore if the two spheres touch each other, and either of them, spontaneously — or else unwillingly, that is, by force—applies itself to the other, then there arises only one sphere ; for the vorticles tend to a state of harmony and equilibrium, and if they cannot attain this, the motions are destroyed, and together with the motion the sphere, and together with the sphere the figure, and consequently together with these the magnetism.

Still, however, in the middle distance between the magnets thus applied, the arrangement and motion of the vorticles are nearly contrary to one another ; but at each side they more inflect themselves toward their natural and homogeneous position. Consequently in the middle of the column thus formed, there is a disjunction of the parts;

but at the sides or laterally, a conjunction. Thus in fig. 30. Suppose A and B to be two magnets, g

Fig. 30.

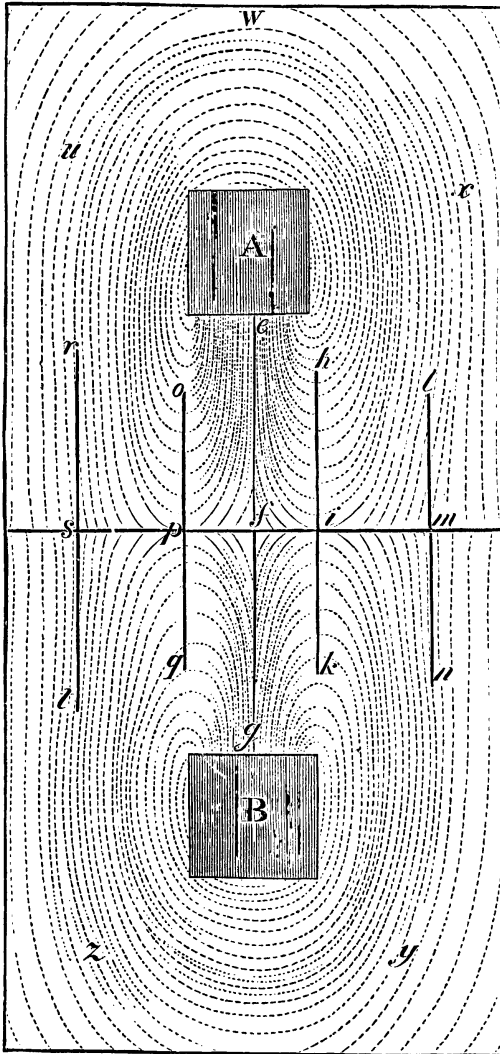

and *e* poles of the same name, either south or north. Then inasmuch as in this position the motions or gyrations of the parts are contrary to one another, the vorticles which are in the diameter and middle distance,

cannot possibly dispose themselves mutually into a similar arrangement or be reduced to an harmonious or concordant motion, as is the case in /. But because as in nature, which is mechanical, all discordant motions tend to one which is synchronous, similar, and equilibrant, the vorticles on both sides are more and more compelled to bend' themselves from their middle point of coalition to *p* and *i*, where they are parallel and neither attract nor repel. Still further on toward the sides, they so apply themselves to each other as to originate a motion homogeneous and similar as far as *m* or *s*, where there again exists a binding of all the vorticles; so that at a certain distance from the middle there is formed a binding of each sphere, or, by reason of this binding, a conjunction of each magnet. Nearer, however, to the middle, or at *f*, there is a disjunction; because there is a mutual opposition and contrariety of the motions of the vorticles which touch one another. The spiral gyrations of the vorticles at the cardinal plane or middle Coalition of each sphere, by sequence from our principles, are similar to one another. Thus in fig. 31 ; the spires *aa* and *bb* flow in

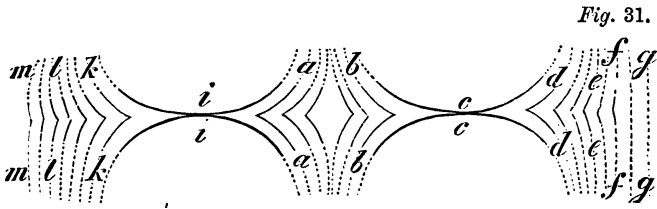

a direction contrary to each other; but in a direction less contrary towards *ii*; and still less contrary at *ii*, where the position of all is parallel and horizontal and where there is neither disjunction nor conjunction. From this place they grow oblique and perpendicular toward their homogeneous position; as from *c* toward *d, e, f, g*; or from *i* toward *k, l, m*. For if, as in fig. 32, the motions of the moving spires were such as *GH* or *AB*, then would the motion of one repel from itself the motion of the other ; but this it would

Fig. 32.

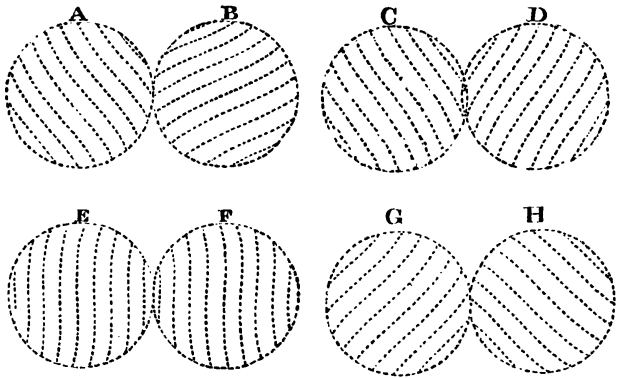

do in a less degree in CD, in a still less in EF, where neither any binding nor separation of the spires can take place. The fact of the vortices being arranged in such a manner by the opposition of poles that are similar and of the same name, results from the mechanism of their motions. For it is from principles of mechanism, that in the middle distance and diameter they cannot be directly deflected, that from the middle they begin to deflect themselves gradually, that at some distance from the middle they arrange themselves evidently into a state of harmony and equilibrium as regards their situation and motion, that in the middle there is thus a state of opposition and repulsion, but at the sides a state of binding and conjunction. Indeed the mechanism may be visibly presented, if you take a number of wheels loosely connected in a line like the links of a chain, and set them revolving among one another upon their axes. In this case we shall see those which are directly opposed to each other exciting a state of commotion, we shall see one running counter to another, one driving another and itself being driven into a contrary direction, some repelling and others being themselves repelled ; in short, we shall see a state of mechanical conflict. Those, however, which did not revolve in opposite directions, if free space were afforded, would not produce such collisions, but would gradually and in an

orderly way accommodate themselves in a body to the motion and influence of others opposing them, till finally there would be peace, and all would become harmonized into one motion and arrangement. So also the magnetic vorticles, if they run counter to one another by reason of a contrariety of motion and position, commence among themselves a state of conflict, and as in a battle, begin the onset impetuously, and if they have not free space, with unallayed energy contend one with the other, and in their rushing along enfold and endeavour to commingle one another's spires and motions. Where, however, because other vorticles oppose, they are not able to unfold themselves and their interior forces, they do not present such a scene of discord and collision, but consociate their motions and spires, and embrace each other as if in confederation. Thus does nature with her motive forces tend to a state of equilibrium.

2. If poles of the same name are turned toward each other, then the magnets are partly repelled and partly attracted ; and their repulsive force is increased according to the distances and ratio of the spheres, but at a smaller distance is gradually diminished. Thus in fig. 30 (p. 298), where the magnets are represented as at the greater distance from each other, their repulsive force is within the boundaries *opq* and *hik*, because all the vorticles within that breadth or column are compelled to observe a more or less oblique position. At lesser distances between the magnets, the attractive force becomes greater and greater within *hik* and *Inin*, or between *opq* and *rst*. Thus in the middle the sphere has a repulsive force, at the sides an attractive force; and inasmuch as the repulsive overcomes the attractive, it follows that the separation becomes greater and greater according to the distance and according as the vorticles meet nearer each other and with more interior spires. If now the magnets be brought still nearer to each other, as in fig. 33, the attractive force is increased, because the space or column *eo* or *hl* is enlarged. And were the force of binding at *eo* and *hl* as great as the repulsion at *eh*, there would

result an equality and similarity between the two, nor would there exist at that distance any repulsion or attraction.

*Fig. 33.*

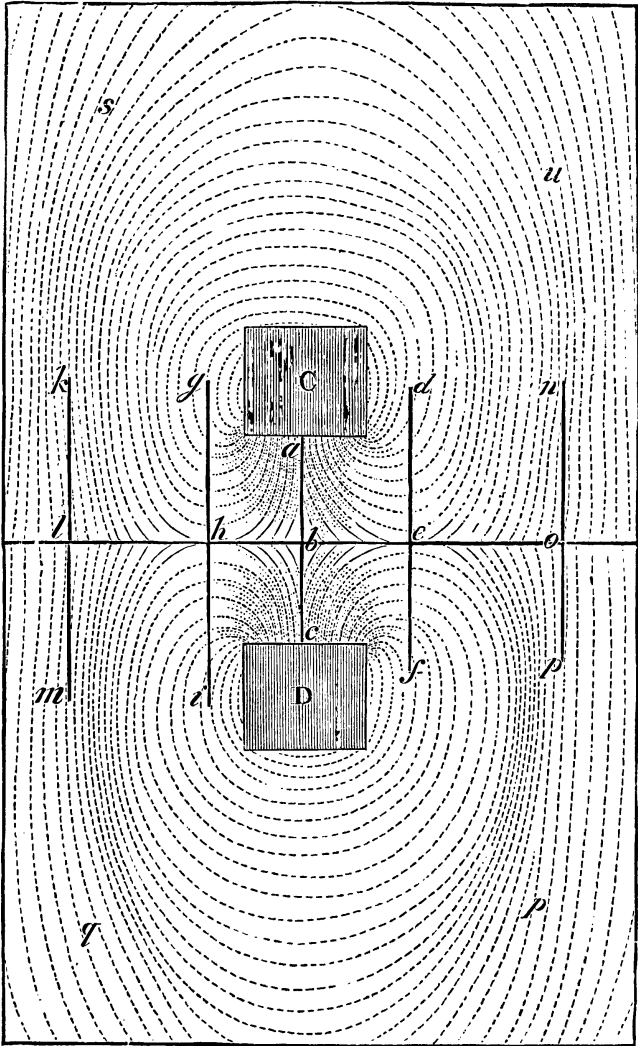

Therefore two or more magnets, having inimical poles opposite to each other, partake of both forces, and present, with the

same equality and inequality, increments and decrements at various distances according to the connection and extension of their spheres—all of which may be made a matter of calculation, provided the magnets are absolutely similar to each other.

Hence also it follows, that when two or more magnets are opposite to each other, then in the space outside their perpendicular line, they co-operate, though the poles assume an obliquity however small, or though the magnets be removed, however slightly, out of the diametric line of opposition. For the repulsive force still remains either greater or less according to the distance within its own space, such as *abc, def*, fig. 33 ; but if the magnets were moved even slightly out of the diametrical line, in other words, if their poles were placed obliquely to each other, then also the repulsive space would assume an obliquity; in like manner the space *Ih* would become greater or less than the space *eo*, and consequently the attractive force would become greater or less on one side than on the other, the repulsive space giving to the sphere an oblique direction ; and so on.

3. Between the distances and repulsive forces of magnets, there cannot be any constant rule of proportion, unless the magnets, together with their spheres, are absolutely alike : just as in the same way there cannot be any constant rule of proportion between the distances and attractive forces of two or more magnets. For if in respect to their virtue, the rectilinear direction of the parts, the quantity of effluvia, the force of attraction at their ends, their own figure and that of their sphere, as also an exactly diametrical and opposite position, the magnets were absolutely alike, in this case the ratios between them would be constant, and we should no longer have to ascertain them from experiment.

4. If therefore two or more magnets are so applied to each other, that the homogeneous or agreeing poles mutually face each other; then from two or more spheres arises a single larger sphere having two poles, one at each end of the magnet,

and the distance between the magnets becomes its axis, equalling the entire side of each magnet. If however two or more magnets are so applied to each other, that their poles are parallel, but their equators opposite to each other, then from two or more spheres arises a single larger one, having four poles, two supplied by each magnet; the case however is otherwise if inimical or poles of the same name are opposed to each other. From these circumstances, assumed as a basis, we may proceed to ascertain the nature of the coalition of the spheres, or what must be the figure of the larger sphere if more than two magnets are brought together, as also what it must be if two or more are placed opposite to each other in another position more or less oblique from the axes or equator and at various distances and angles. In eliciting these truths, bringing them under general rules, and reducing them to geometrical principles, philosophy might employ her proportions and analytical computations for many an age, while geometry alone would fill numerous volumes with its illustrations by curves, spaces, and lines.

#### MUSSCHENBROEK'S EXPERIMENTS.

##### “EXPERIMENT XIII.

“Magnets not only mutually attract, but also mutually repel each other; and both the poles of one magnet repel both the poles of the other; the poles however which repel are different from the poles which attract each other. Desiring to learn, with regard to the repulsions of the magnets, whether they were greater or less than the attractions, whether they observed any regular or irregular relation to the distances, I thought that I might very effectually accomplish my wishes by pursuing the same method that I had adopted in ascertaining the attractions ; with this difference, that whereas in the latter case I had placed the weights in the scale to counterprise the attractions, I should have now to place them upon the magnet,



in order to make it heavier, and approach the lower magnet, as it was repelled, or sent in an upward direction.

“I again fixed the large round magnet NO firmly on the table, while I suspended the other magnet, which was the block used in experiment v., from the arm of the balance; and then counterpoising it by placing weights in the opposite scale, I observed the following measures of repulsion :—

Distances in measured by- Inches and Lines. Apothecaries' Grains.	Repulsions	Distances in Inches and Lines.	Repulsions measured by- Apothecaries' Grains.
14.. ..0 = 1		7.... 9	1
13 .... 0 = J		7.. .. 6	u
11 .... 9 = 1		6.. .. 9	2
10.. ..9 = J		6.. ..4	
10 .... 4 = 0	} Or simple equili- brium, such as ex- isted before the experiments	5 .... 9	2
9.. ..10 = 0		5.. ..4	2
9.. ..4 = I		5.. ..2	
9 .... 0 =		4.. .. 9	3
8 .... 3 = f		3.. ..10	1

“ When I moved one magnet nearer to the other, it was no longer repelled but attracted ; for at the distance of 3 inches and 6 lines the attraction was equal to 7 grains. I am not aware that any greater anomaly could be observed than was shown by these repulsions, which at the great distance of 14 inches were considerable, and at the lesser distance of 10 inches ceased altogether, then again at a lesser distance down to 4 inches continued to increase, at a still lesser distance decreased, and finally became changed into an attractive force. Poliniere, in his *Experiences de Physique*, (Paris, 1728, p. 281), has also observed that the pole of the magnet, which at a greater distance repelled the extremity of the mariner's needle, when it was moved nearer attracted it. In either of these cases, the effects are very anomalous ; therefore I thought it was better to repeat my experiment with another magnet, the same that I had used in experiment ill., either to afford me the opportunity of making some further discovery with

respect to the mutual repulsions of magnets, or else to confirm the former anomaly. The results were as follows :—

“ EXPERIMENT XIV.

Distances in Inches and Lines.	Repulsions measured by Apothecaries' Grains.	Distances in Inches and Lines.	Repulsions measured by Apothecaries Grains.
13.. ..0	= 0	1... 11	= 12
11.. ..11	= i	1.... 4	= 17
10.. ..9	= t	12	= 24
9.. ..9	= 1	10	= 24
6.. ..1	= 2	7	= 25
5.. ..1	= 3i	6	= 25J .
4.. ..0	= 6i	5	= 27
2.. ..9	= 11	4	= 29
2.. ..3	= 13	0	= 44

“These experiments relating to the repulsions of the magnets required much greater skill than was requisite in determining the attractions, for I remarked that the suspended magnet constantly deviated from the right line passing through the poles; therefore I was obliged to attach it to a copper wire, and this wire to the beam, in order to keep it permanently in one and the same right line over the other magnet.

“In these experiments, however, a greater order or regularity, as it may be called, is observable than in those made with the former magnet, since the repulsion increased as the distance decreased, and continued to do so down to the point of contact

“ To any one, however, who examines the foregoing table of repulsions, it will be evident that there is no definite ratio between the forces and distances, in like manner as none could be found in the case of the attractions.

“ The attraction, however, is much greater than the repulsion ; for when the magnets were in direct contact and the attraction was equal to 340 grains, the repulsion was equal only to 44 grains ; and by comparing our third experiment with

the present, the great degree of difference between the two is easily observable.

“EXPERIMENT XV.

“ I wished, moreover, to ascertain whether the repelling forces of each pole of the same magnet were equal, or in what manner they varied; consequently I inverted the magnet employed in the last experiment and which hung from the beam, so that the other pole now faced downwards : I also in like manner inverted the round magnet placed upon the table, and then took the following observations :—

Distances in Lines.		Repulsions measured by Apothecaries' Grains.	Distances in Lines		Repulsions measured by Apothecaries' Grains.
12	=	30	5	=	34
11	=	32	4	=	32
10	=	32	3	=	28
9	=	33	2	=	27
8	=	34	1	=	25
7	=	36	0	=	13
6	=	36			

“ The results here are so remarkable, that I at first doubted whether the experiments had been rightly conducted ; but on repeating them with greater care, I found the repulsions precisely the same. At the distance of 12 lines these repulsions were great; they continued to increase to the distance of 7 lines, after which they decreased until at the point of contact the repulsion became equal only to 13 grains. It may be asked, therefore, what there is in magnets which produces this anomaly ? Shall I say that the stone I examined consisted of parts exceedingly heterogeneous, some of which attracted and others repelled ; and that these opposite forces, proceeding from the same point in the magnet, disturbed the proportion either of simple repulsion or attraction ? This seems very likely; so that he who wishes to know the degree of the repulsion only, ought to have in view also the attractive force of the same poles, and to add this to the

repelling force ; the sum of both would then indicate the degree of the repelling force. It is evident, however, that the attraction together with the repulsion is given in experiment XIII., in which, at the distance of 3 inches and 6 lines and less, the attractions prevailed over the repulsions, and hence the magnet hung from the beam was attracted, not repelled ; in experiment xv., at the distance of 5 lines, the proportion of repulsion was less than that of attraction, hence likewise the repulsion seemed to diminish as the distance diminished, while nevertheless the repulsion had undoubtedly increased in proportion as the magnets were made to approach each other. This repulsion, however, was so disturbed by the attraction, that the greatest irregularity was the consequence—an irregularity which was observable in the experiments themselves, since at the distances of 10, 11, 4 lines the repulsions were equal, and at a distance of 7 lines the repulsion was greatest. In this view I was confirmed by adding to the repulsions the attractions observed between these magnets in experiment h i., for then a certain regularity became observable, the repulsion being greatest at the point of contact, less at any given distance between the magnets, and decreasing as the distance increased. This will be evident from the following table, which exhibits the attractions observed in the third experiment and the repulsions observed in the fourteenth experiment, together with the sum of the attraction added to the repulsion.

Distances in Inches and Lines.	Attractions measured by Apothecaries' Grains.	Distances in Inches and Lines.	Repulsions measured by Apothecaries' Grains.	Sum Total Repulsion and Attraction.
12 .. 0 =	W	11 ... 11 =	i	W
11. .. 0 =	4	10 ... 9 =	/	/
12 =	70j	12 =	24	94J
10 =	87	10 =	24	111
7 =	114	7 =	25	139
6 =	131	6 =	25	156J
4 =	172	4 =	29	201
0 =	340	0 =	44	384

“ Now attending to the numbers which express the sum of the repulsion and attraction, I am unable to observe between them and the distances any "constant ratio. If there is any it will not be great, and will be less than the simple inverse proportion of the distances, commencing the computation from the point of contact; for  $6 : 4 :: 201 : 134$ , instead of  $156J$ . Again,  $7:6::156J:134$ , instead of  $139$ . Again,  $10: 7 :: 139: 97fk$  instead of  $111$ . Again,  $12: 10 :: 111 : 92J$ , instead of  $94$ . Still I doubt not that some constant proportion would be found to exist between the distances and the repulsions, provided the latter alone could be obtained and calculated separately from the interference of any other cause; nay, even the attractions themselves may possibly observe a constant ratio, but are probably disturbed by the repulsions ; for each pole of the magnet exhibits both a repulsive and an attractive force, consequently from one and the same pole there issue an attractive and also a repulsive force. When the opposite poles of two magnets are turned toward each other, the attraction prevails over the repulsion ; when the inimical poles face each other, the repulsion prevails over the attraction ; therefore the action is always compounded of attraction and repulsion. Hence the two ratios which compose the action observed in the experiments must be separately disentangled from the observed quantities, in order to be made the subject of a distinct and separate computation—a process which will be found extremely difficult—until however we have succeeded in it, we shall be unable to arrive at the true proportion of attraction and repulsion. In such a state of things it will be well to suspend our judgment, and simply to record our observations; thus leaving it to posterity, from an increase of data and a more matured knowledge, to elicit further results. Nor will my silence be any dishonour; for the wisest Florentine philosophers who have treated of the magnet have furnished us only with the results of experiments, without adding explanations; a course they pursued lest they should offer only fictions

for truths, hypothesis in place of proof, and ashes for treasures.

“ As from the foregoing experiments I have not been able to ascertain any ratio between the forces, I was led to doubt whether it was possible, by any of the methods I had hitherto tried, to detect, at the various distances, the proportion between the forces, even supposing such a proportion to exist; since the two magnets acted one upon the other, and hence the forces proceeding from the two by their mutual encounter disturbed the proportion. Therefore, if I could employ a single active magnet, the other being deprived of all its forces, there appeared to be some hope of detecting much more easily the proportion of the forces. An inert magnet of this kind could, however, be supplied only by pure and good iron, such as it is when just taken out of the fire, possessing no magnetic force, neither struck nor violently seized with the tongs, but having been gently and cautiously handled. I now turned my attention, therefore, to experiments with the magnet and iron, such as I am about to describe in the ensuing chapter.

“ Both in conducting and describing these experiments I have been prolix, perhaps even to a degree of irksomeness, but not without reason; because had I made a mistake in one experiment, I had thus the better chance of discovering it in another. Besides, the prince of all natural philosophers, Sir Isaac Newton, has assumed a different proportion of the magnetic forces; so that I ought not to treat so important a subject lightly, or content myself with only a few experiments. For the author, who can never be sufficiently praised, has observed in his *Philosophice Naturalis Principia Mathematica*, (Cantabrigiae, 1713, Lib. i., sect, xiii, prop, lxxxv, p. 192):

\* If one body is attracted by another, and the attraction be very much stronger when the former is contiguous to the attracting body than when it is separated even by the smallest interval of space, the forces of the particles of the attracting body, as»the body attracted recedes, decrease in a greater

than the duplicate ratio of the distances from the particles.' Again (Lib. iii., prop, vi., cor. 5, p. 368), we find the following remark : <sup>4</sup> The force of gravity is of a different kind from the magnetic force, for the magnetic attraction is not in proportion to the matter attracted. Some bodies are more attracted, others less, many not at all. Moreover, the magnetic force in one and the same body may be made greater or less ; sometimes it is far greater in proportion to the quantity of matter than the force of gravity, and in receding from the magnet does not decrease in the duplicate but almost in the triplicate ratio of the distances, as far as I have been able to ascertain from some rough experiments I have instituted.' Would that the experiments here referred to, and from which Newton made his foregoing inferences, had been recorded ! Perhaps a man of such amazing penetration in the mathematical sciences has found out some method of separating the attractions from the repulsions, and discovered that they decrease in the triplicate ratio of the distances. As, however, he has come to no further conclusions on this subject, we can neither reject nor receive his opinion ; and if we consulted only our own experiments, we should say that the attractive forces of the magnet do not decrease in so great a ratio of the distances." (*Op, Cit.*, pp. 28-34.)

## CHAPTER VI.

### THE ATTRACTIVE FORCES OF THE MAGNET AND OF IRON.

#### A PRIORI OR FROM FIRST PRINCIPLES.

When iron is applied to the magnet or the magnet to iron, then out of two spheres there arises one that is larger, and which encloses both the magnet and the iron, but not in the same way as when one magnet is applied to the other. We have already treated of the way in which two spheres coalesce into a larger one, when one magnet is applied to another. But as the phenomena produced by the magnet in its action upon iron are so very obvious, and so greatly excite the wonder of observers, it may be worth while to present to view the causes of these phenomena, as explained by the principles already laid down. We learn from the first chapter of this our second Part, that the sphere surrounding the magnet has a perfectly regular figure; that the effluvia passing out from iron are purely magnetic, but not cohering with one another so as to form a sphere perfectly regular and, as it were, returning into itself; consequently that there is a great quantity of effluvia about the iron but possessing no orderly sequence, no regular figure, no geometrical arrangement, except in so far as it extends on all sides from the iron as radii, consequently having no mechanism enabling it to operate upon the neighbouring sphere by means of reciprocal attachment. For unless a sphere is of such a nature as to have its parts connected together into a regular form, series, and sequence, and to return again into itself so as to connect one portion of itself with another, it is possessed of no contiguity, it has no



relation to an axis, nor has the axis any relation to the iron as a magnet; consequently there is no magnetic force. On the other hand, if two spheres are rendered contiguous by being brought together, and if one of them is regular and if its parts are attached, while the parts of the other are loose or unattached, the first will dispose the second into a regular arrangement of parts, and reduce it to a geometrical figure like its own. For the individual parts or vorticles of the sphere surrounding the magnet are mechanically reduced into a regular sphere ; and if more vorticles be added, these also are reduced into the same and similar sphere. For the effluvia surrounding the magnet are urged into a state of order by the orderly motion of the vorticles themselves ; an operation which is purely mechanical ; because it is in a regular figure that the greater force and connective power reside. Therefore the greater the quantity of effluvia, the larger the sphere around the magnet, and contrariwise. Now by the approach of the iron there is a fresh accession of truly magnetic effluvia, which are consequently brought into a series and consociation with those which surround the magnet in regular order. On the part of the iron, therefore, the sphere is enlarged ; and, according to the mechanism, no other common sphere can be formed than one similar to the sphere, fig. 34, where *A* is the magnet, *D* the iron, *b* the pole of the magnet. In this case all the intermediate vorticles of effluvia arrange themselves into the direction of an axis, and with one consent proceed from the magnet toward the iron and beyond it; so that all the volume of effluvia, together with its vorticles at *gh*, are reduced into one common sphere : so that on the side of the magnet facing the iron the axis is elongated beyond the iron, and then turns and curves itself back, almost -in the same manner as if there were no iron ; besides which, on the part of the iron, the axis is carried out to a greater distance. What is the nature of the common sphere of two magnets, and what the difference between this and the former, will be seen in the figures.

Fig. 34.

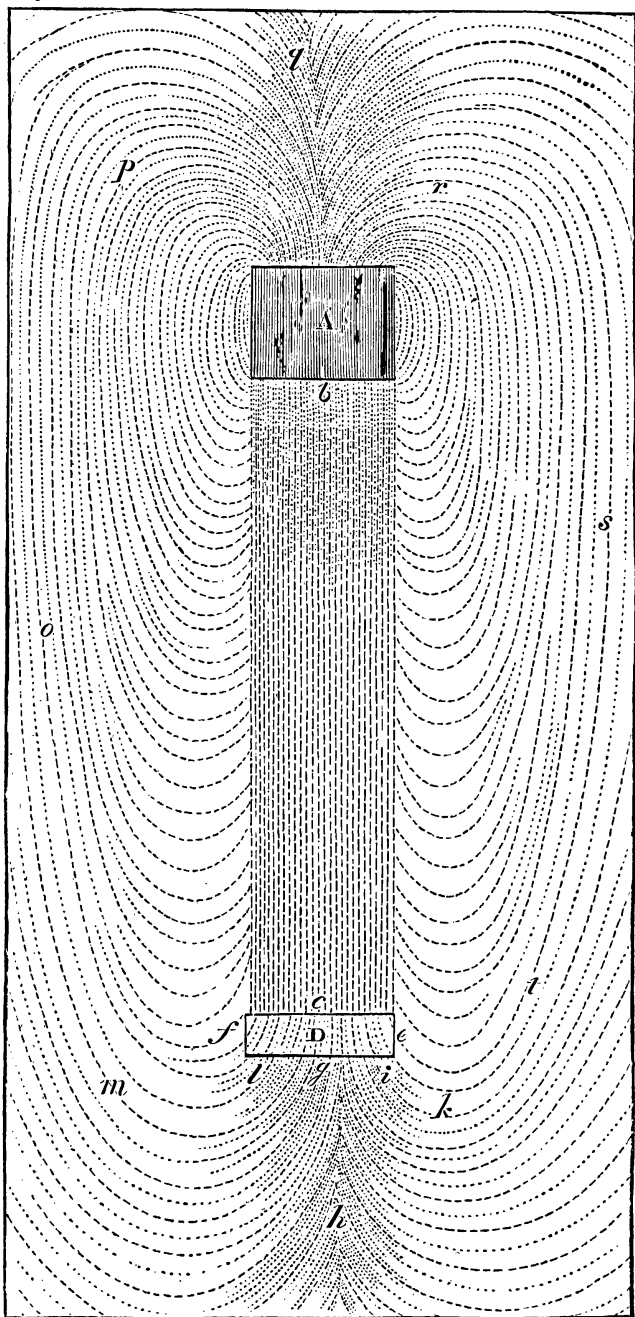

If therefore the two spheres of the magnet and the iron coalesce into one ; if, consequently, both the bodies have the same kind of contiguity, stream, and volume ; if they are thus connected together by a rectilinear arrangement of the moving vorticles; it follows that the action of the magnet upon the iron is the same as the action of the iron upon the magnet. The case may be illustrated by supposing weights attached to the ends of a piece of wire, so that being thus connected one cannot move without the other. If we draw the one to the right, the one on the left follows; if we draw the one to the left, the one on the right follows. By means of one and the same wire, one weight follows the motion of the other, and the action of one is thus the action of the other.

2. The reciprocally attractive force of the magnet and the iron is greater than the attractive force of two magnets ; as is evident from the coalition of the two spheres into a single large one. The whole distance between the iron and the magnet coalesces into one common axis, which, having its beginning in the magnet, extends itself out beyond the iron ; and by bending from the side, unites itself with the common sphere; and so each body becomes fastened to the other by one and the same axis. The common sphere, however, which embraces and encloses two magnets, does not possess an intermediate axis similar to the one we have just described ; for in this case each magnet has its own axis, which it sends out to meet the other; therefore in the intermediate distance or plane of coalition, the force is according to the distance from each magnet. In bringing together the iron and the magnet, the axis, as is evident from our diagram, proceeds from the magnet toward the iron ; therefore the iron is in the same connection with the magnet, not only as to its surface opposite the magnet, but likewise as to its interior parts, and its other surface also. Thus in fig. 34 (p. 314), there is not only a nexus at *c* but also in the very interstices of the iron, or with the interior structure *D* of its parts, as also on the other side *it*. Thus the whole mass of the iron lies in the

same stream and vein, and in direct contact with those of the vorticles of the magnet; and forms a connection with the magnet on both sides, as also within its own interior parts. Moreover, there is added a considerable portion of truly magnetic effluvia ; and consequently the magnet acts upon the iron more strongly than upon another magnet, upon which indeed it cannot act except by a coalition of the vorticles<sup>^</sup>in the intermediate distance.

3. The magnet exercises its greatest force upon iron of a given proportion of mass and thickness; the force is smaller if the iron is too thin, or if it is too thick. This follows from the causes before mentioned. For the iron coheres with the magnet, because all its parts are in the same stream, connection, and contiguity; both those which are in the surface, and those which are interior. If the iron is too thin, there are fewer parts that cohere in the stream; if it is too thick, the iron is not traversed regularly by the stream ; nor does the axis extend beyond the iron on the opposite side, as it does in the other case, but terminates and disappears in the structure of the iron; so that it can no longer, as in the former case, operate on both sides and in all directions, as may be seen in fig. 35, where the iron B is penetrated by

Fig. 35.

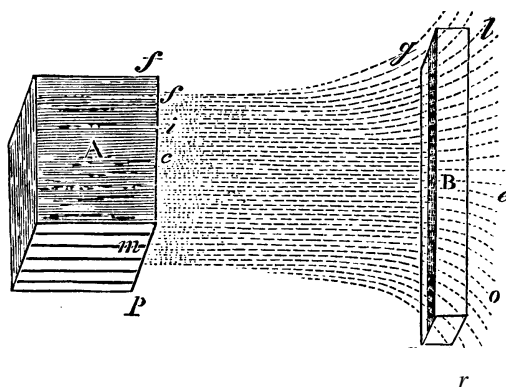

the common axis extending toward *e* and *o*, and is thus

entirely surrounded by one and the same direct stream. But in fig. 36 the iron is not penetrated regularly except as

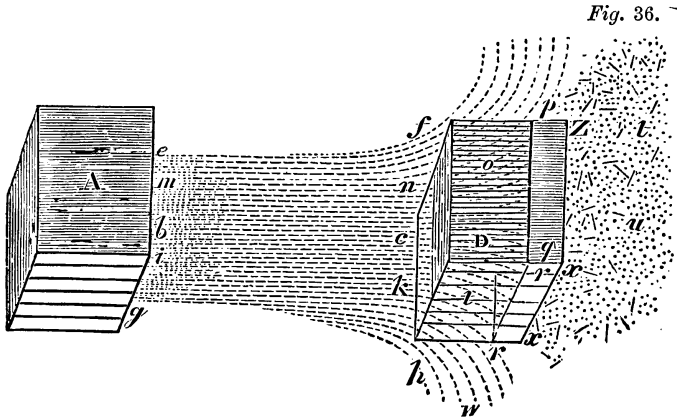

faras^r; hence on its other side no axis is formed; and consequently at *Ztux* no regular figure. Therefore no magnetic virtue and power exist, because there is no mechanism. The nature of the sphere of the effluvia surrounding the iron, may be seen in chap. XII. of the present Part.

Iron, like all other metals, abounds in interior spaces and interstices, in which flow effluvia with vorticles similar to those which are fluent without. Hence those which flow freely in the larger interstices may be reduced into the same order and connection as those which flow outside ; thus an axis is formed on both sides, and running throughout the iron if its thickness is not too great. Therefore it follows that in regard to the mass and thickness of the iron there is a maximum and minimum, upon which the magnet exercises its greatest force.

4. The magnet exercises its greatest degree of force upon iron of a given proportion of size and surface ; a less degree if the iron is too small; and a less also if it is too large. If it is too small and does not equal the entire breadth of the axis or of the stream, it follows that the plane or area exposed to the magnet is too little to allow the whole force of the magnet to

develop itself; for in this case, it operates on both sides upon a smaller surface, while nevertheless it is capable of operating upon a larger. The breadth of the axis between the magnet and the iron is proportioned to the polar plane or surface of the magnet, and to the plane or surface of the iron. If the plane of the iron is very small, then the intermediate axis at the iron is very small; and consequently there is less attractive force. But if the iron opposite the magnet is very large and bulky, then there is opposite the magnet a larger area, and this is occupied by a larger or wider current. But as the axis penetrates to the other side of the iron, and thence curves itself back into the figure of a sphere, it follows that both above and below, or at the sides, the action of this sphere upon the iron is contrary to and reacts upon itself; thus the real amount of the attractive force of the iron and the magnet is the difference between the action and reaction, as in fig. 37, where A is the magnet, B is the iron; the area opposed to the magnet is *feBhi*; the common axis passes beyond, whence it begins to curve itself, and to turn back, as from *k* toward *w*, from *I* toward *fe*, from *o* toward *p*, or from *n* toward *i*, and thus it acts with a contrary force upon *h* and *i*, or upon *f* and *e*. Consequently by means of this contrariety of force the direct action becomes less, whence also the attractive force is equal in amount to the difference between the two actions. Hence it follows that in regard to the size and surface of iron, there is a maximum and minimum, upon which the magnet exercises its greatest force. In like manner, iron of a determinate size ought at least to equal the polar plane of the magnet, *zcx*.

musschenbroek's experiments.

“If, as before, a magnet is hung by a long cord from the beam of a balance, and weights are placed in the opposite scale to counterpoise the magnet; if a mass of iron is firmly

Fig. 37.

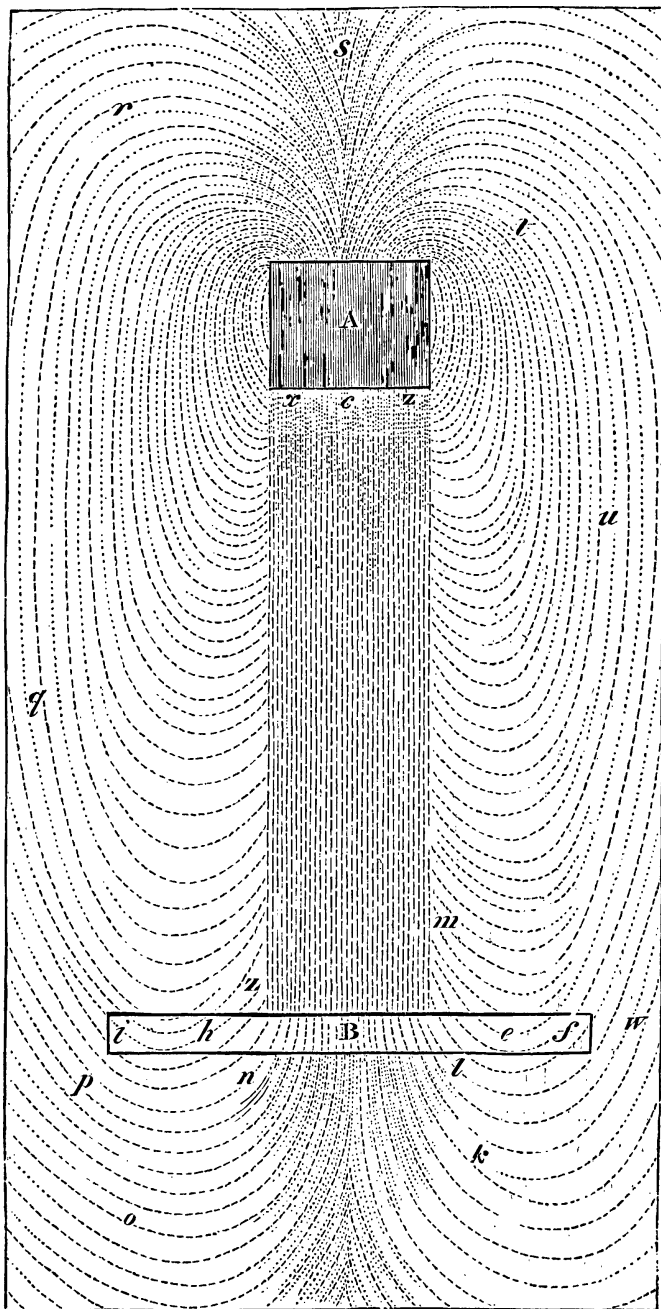

fixed below, a few inches from the magnet and in a line with it passing through the iron and the magnet perpendicularly to the horizon, the magnet will then descend toward the iron ; in which case

‘ The loadstone, burning anhelation finds,—  
Appears, from friendly iron, wounds to feel ;  
And love’s delightful warmth pervades the steel.’<sup>1</sup>

Now if we wish to make the magnet keep at the same distance from the iron, it will be requisite to throw several weights into the scale, which by their weight will raise the magnet, and as it were pull it away from the iron with as much force as the magnet exercises in approaching it. The additional weight beyond that which was originally thrown into the scale to produce the equilibrium, shows the amount of the attraction of the magnet to the iron; and consequently by this expedient we learn the mode of determining the magnetic forces exercised upon iron placed at various distances.

“ In whatever way the magnet be turned, while continuing to be attached to the beam, it always approaches the iron.

“ This experiment proves that one magnet acts not only upon another magnet, but also upon iron. Nor ought this to excite our surprise. For the magnet is only a stone consisting of good iron together with an intermixture of earthy parts. The stone derives its virtue not merely from its composition of earth, but from its possession both of earth and iron ; for this reason its forces are the stronger in proportion to its greater amount of iron and of weight. That the particles of iron confer a force upon the stone may easily be proved ; for when a piece of iron had been fixed into a stone and remained in that position for several years, and the parts corroded with rust had permeated the pores of the stone, the stone became magnetic; as indeed, according to what I have before observed, has been proved by repeated trial, and confirmed by [Gabriel Philippe] de la Hire, in his observations

<sup>1</sup> Claudianus’ *Eidyllia* 5, “Magnes,” l. 48. Translated by A. Hawkins.—*Trs.*



inserted in *Histoire de VAcad&mie Roy ale des Sciences*, 1705, p. 5, and *Memoires*, p. 97, where he says, he enclosed a piece of wire in a stone, but so placed, that its length lay in the direction observed by the magnetic needier-----

After ten years the stone was found to be a true magnet, the wire having been corroded by rust. On another occasion he rubbed some wires upon a magnet before enclosing them in a stone, desiring to ascertain whether a stronger magnet might not thus be produced ; but in this case he did not observe that the stone became possessed of any greater magnetic powers. The iron, therefore, which is in the magnet exercises its power of attraction in connection with the earth which is mixed up with it; if, therefore, this should act upon, the iron parts which constitute another magnet, it is not to be wondered at if it should act also upon pure iron, or on the purest kind of magnet possessing no mixture of stone ; for this we may call pure iron. Altogether in the same way the magnet acts upon all bodies possessing any intermixture of iron; nay, possibly even upon those bodies which are possessed of no iron, but have only the same earthy attractive matter. For it is in this way that it acts upon certain plants ; upon burnt bricks of an exceedingly red colour, as Cabeus has remarked [*Philosophia. Maynetica*], lib. i. cap. xvii., p. 63 ; upon the *colcothar* [*caput mortuum*] of vitriol; upon the shining and black dust obtained from Indian sand, and which never contracts a red colour, of which we shall speak further in the sequel: upon the black dust which remains after the distillation of linseed oil and oil of turpentine, as is remarked by Geoffroy in *Histoire de VAcaddmie Roy ale des Sciences*, 1704, *Mem.*, p. 278 ; upon the garnet, a gem, but only when it is tinged with a deep colour, according to Boyle; (see *Acta Eruditorum* Lipsise, 1693, p. 182);<sup>1</sup> upon the stone of Lough Neagh when calcined, as is observed by Molyneux in the *Philo-*

<sup>1</sup> This refers to a review, in *Acta*, of Boyle's *Experimenta et Observationes Physical* Boyle says, pp. 113-114, that, judging from the deep colour of some garnets, they contained metallic substances, iron or steel. He found that a magnet attracted them.—*Trs.*

*sophical Transactions*, vol. xiv., p. 820 ; also upon the impurities of glass, according to Helmont, *Opera Omnia*, Francofurti, 1707, p. 727. Whence we are led to see the error of Pliny, who, in his *Naturalis Hist or ia*, lib. xxxiv., cap. xlii., in his observations upon iron, says, it is the only kind of matter which receives the forces of the loadstone.

“ Inasmuch, however, as all action is equal to reaction, it is not possible for the magnet to act upon iron, unless the iron acts reciprocally upon the magnet, and therefore approaches the magnet in the same manner as the magnet approaches the iron. Desiring, however, to confirm this position by experiment, I hung a magnet from the end of a long string attached to the beam of a balance, and produced equilibrium by putting a weight into the scale on the opposite side. Then I hung a mass of iron of the same weight as the magnet from another beam by four cords or strings, distant from one another so that the magnet and the iron were almost in the same perpendicular line; and in this case also I produced equilibrium. As soon as the two were brought so near to each other as obviously to operate on each other, the iron approached toward the magnet and the magnet reciprocally as much toward the iron. Therefore, in order that the two bodies might remain separate from each other, it was requisite to place a greater weight in the scale at the end opposite to the beam from which the magnet hung; by this means the magnet was raised: it was next requisite to place upon the iron with great nicety an equal weight by which it should be proportionably depressed, and, as it were, pulled away from the magnet. This being done, equilibrium resulted ; therefore it is evident that the action of the magnet upon the iron is equal to the reaction of the iron upon the magnet. The same fact may be exemplified in another manner. Thus if we place the iron and the magnet, each in its own little boat, and let them float upon plenty of water, each will approach the other with an equal impetus, and mutually meet at the

middle point between them. Let us however pass to our other experiments, in which we endeavoured to determine by calculation the operations of the iron upon the magnet. \_

“ EXPERIMENT XVI.

“ I took a mass of iron which was in the form of a block with parallel sides, the base of which had an area of 224 square lines; its height 5| Rhenish inches. This mass, which had never touched a magnet, I placed upon a table, so as to be fixed upon it; I then hung a magnet, which was also in the form of a block and which I had used in my fourth experiment, from a cord attached to the beam of a balance so that the axis connecting each pole was perpendicular to the horizon, and passed through the axis of the iron. The magnet, which was brought into equilibrium before making the present experiment, I let down at various distances successively from the iron, as in experiment 11. I then noted the weight which it was requisite to place in the opposite scale in order to restore equilibrium, and which was always equal to the attractive forces of the magnet and iron. The results may be seen in the following table :—

Distances of Magnets in Inches and Lines.	Attractions measured by Apothecaries' Grains.	Distances of Magnets in Inches and Lines.	Attractions measured by Apothecaries'' Grains.
3 .... 7	= 1	7	= 29
2 .... 11	= U	6	= 32
2 .... 6	= 2	5	= 44
1 .... 7	= 6	4	= 52
I .... 4	= 10	3	= 72
11	= 14	2	= 96
10	= 16	1	= 110
9	= 17	0	= 180
8	= 21		

## “EXPERIMENT XVII.

“ But since the foregoing block of iron was extremely large and heavy, I had another made of the same weight as the other magnet examined in. experiment iv.; and which exposed to the suspended magnet a surface as large as that of the preceding; for I was of opinion that the attractive forces would thus be found to be the same as in experiment IV., when the iron was similar to the magnet, except that it was not so thick, in consequence of the greater weight. The experiment, made with the same magnet as in the preceding case, furnished the following results :—

Distances of Magnets in Inches and Lines.		Attractions measured by - Apothecaries' Grains.	Distances of Magnets in Inches and Lines.		Attractions measured by Apothecaries' Grains.
5 ... .0	=	1	6	=	76'
3 ... .3	=	2	5	=	96
2 ... .0	=	8	4	=	109
12	=	35	3	=	131
11	=,	37	• 2 *	=	179
10	=	43	1	=	231
9	=	47	<i>j</i>	=	343
8	=	57	0	=	720
7	=	66			

## “EXPERIMENT XVIII.

“ Hitherto it is the magnet that has been suspended. I was now desirous, therefore, in turn, of suspending the iron, and letting the magnet rest upon the table. Consequently I now hung up the iron block, the base of which had an area of 224 square lines, and 5 J Rhenish inches in height. This block was attached by a long cord hung longitudinally from the arm of the balance, and was then brought into exact equilibrium. I next placed upon the table the spherical magnet NO, with

its pole turned upward in such a manner that the line connecting the poles passed through the axis of the iron.

This arrangement produced, at different distances from -the \_\_\_\_\_ magnet, the following results :—

Distances of Magnets in Inches and Lines.	Attractions measured by Apothecaries' Grains.	Distances of Magnets in Inches and Lines.	Attractions measured by Apothecaries' Grains.
4 . ... 3	= 0	9	= 106
3 . ... 10	= 1	8	= 121
3 . ... 1	= 4	7	= 140
2 . ... 11	= 7	6	= 164
2 . ... 5	= 10	5	= 201
1 . ... 7	= 24	4	= 229
1 . ... 4	= 37	3	= 285
12	= 61	2	= 361
11	= 70	1	= 472
10	= 84	0	= 1312

“EXPERIMENT XIX.

“ Before examining the preceding observations, I will first take notice of certain additional experiments which I think are not unworthy of attention. These I made to ascertain the difference between the attractions of the same magnet, when the mass of iron was smaller, or of a different shape, or when it was placed in a different position. I therefore took the foot of the armature of a magnet, which had first been made red hot in order to divest it of its magnetic power, and which is represented in Fig. 38. This foot ABCD was only a thin sheet of iron, weighing two ounces; to which was appended the cubic little foot EF, the square end of which F, and which was the one now opposed to the magnet, was about nine lines in the side.- In this case, the attractions between the body and the magnet, at the several distances, were as follow :—;

Fig. 38.



Distances of Masrnets in Inches and Lines.	Attractions measured by Apothecaries' Grains.	Distances of Magnets in Inches and Lines.	Attractions measured by Apothecaries' Grains.
4 .... 6	= 0	9	= 37
3 .... 10	= 1	8	= 40
3 .... 7	= U	7	= 43
2 .... 5	= 3i	6	= 49
2 .... 0	= 61	5	= 54
1 .... 11	= 7	4	= 64
1 .... 6	= 10	3	= 78
1 .... 4	= 15	2	= 114
12	= 25	1	= 184
11	= 30	0	= 1024
10	= 33		

“EXPERIMENT XX.

“ I next hung the same iron foot of armature ABCDEF (Fig. 88) transversely, so that the larger plane surface ABCD faced the pole of the magnet. That part of the iron which hung directly over this pole, was much thinner in the present experiment than the other part in the preceding experiment. From this arrangement the following results were obtained :—

Distances in Inches and Lines.	Grains.	Lines.	Grains.
4 .... 0	= 0	7	= 40
3 .... 10	= 1	6	= 54
3 .... 5	= 1}	5	= 69
2 .... 3	= 21	4	= 79
1 .... 10	= 4	3	= 86
1 .... 2	= 15J	2	= 134
12	= 20	1	= 214
10	= 30	0	= 574
9	= 37		

“ EXPERIMENT XXI.

“ I next tried to find out in what way the magnet acted upon iron filings; for this purpose I took an iron box of the same form and size as the magnet which I had used in the third experiment. The metal of the box was exceedingly thin, and commonly called *Blick*; this I filled full of iron filings; and upon weighing it, found it had less weight than a magnet of the same size; for filings do not form a compact mass. The difference in the weight was 15 drachms. The box was now hung from the beam, and the same round magnet which I had used in experiment in., was fixed firmly upon the table with its pole looking upwards as in experiment ill. On pursuing my observations as before, and ascertaining the attractive forces by means of weights, I produced the following table :—

Distances in Inches and Lines.		Grains.	Lines.	Grains.
9 .... 0	=	0	7	115
4 .... 9	scarcely	anything	6	135
4 .... 0	=	1	5	158
3....3	=	6	4	166
12	=	63	3	221
11	=	68	2	275
10	=	77	1	373
9	=	82	<i>j</i>	460
8	=	103	0	650

“ EXPERIMENT XXII.

“The next thing I did was to pour out some of the filings from the box, until it reached the same thickness as the solid mass of iron which was of the same weight as the magnet. The experiment furnished the following results :—

Lines.		Attractions measured by Apothecaries' Grains.	Lines.		Attractions measured by Apothecaries' Grains.
12	=	59	3	=	221
11	—	62	2	=	275
10	=	72	1	=	415
9	=	78	J	=	460
8	=	94	0	=	710 and
7	=	108			even 772 at other
6	=	134			points of contact of
5	=	149			the same box.
4	=	182			

“ Having made these observations, it may be well to compare the experiments with one another, to educe the consequences that result and to arrive at some useful conclusions, as far as we safely can.

“ *Corol.* 1. It is very evident, then, that the magnet attracts the iron with greater force than it attracts another magnet; for in the fourth experiment both magnets, when in contact with each other, exercised a force of attraction amounting to 128 gr. But in experiment XVI. the same magnet at the point of contact attracted the iron with a force of 180 gr. Consequently the iron was attracted with a greater force than the magnet. This is much more clearly shown in experiment XVII.; where the same magnet, at its point of contact with a smaller piece of iron than in experiment xvi., had a force of attraction of 720 gr., which is more than five times greater than 128 gr. in experiment IV. Further, it affords additional confirmation to experiment V.; for in the latter case the spherical magnet NO, at the point of contact, attracted the other with a force of 340 gr.; but in experiment xviii. the same spherical magnet attracted the iron with a force of 1312 gr.; in experiment xix. it attracted the iron with a force of 1024 gr.; and in experiment xx. it attracted the iron with a force of 574 gr. From these various experiments, therefore, it is very evident, that the



magnet attracts iron more strongly than it attracts another magnet. By this observation I am confirmed in the opinion mentioned in chap. I., namely, that magnets which attract themselves by amicable poles at the same time also repel each other; but the repulsion is overcome by the attraction. In like manner, magnets, when receding from each other by the action of their hostile poles to one another, are nevertheless at the same time attracted; but the attraction is overcome by the repulsion. For how could the iron, which just before had been taken out of the fire and which was not impregnated with any, or at least with very little, magnetic virtue, be attracted by the magnet more strongly than an excellent magnet endowed with attractive force ? unless it is for the reason, that the iron was attracted but did not at the same time repel; or if it repelled, repelled but little.

“ *Oorol.* 2. In these attractions of the iron toward the magnet, there is a maximum and a minimum; for a mass of iron of definite size and form will be attracted by a magnet of definite size. Another mass of iron greater or less will be less attracted by the same magnet ; and the more the several masses differ, either by excess or deficiency, from the mass which is most strongly attracted, the less also will they be attracted. This seems to be proved in experiments xviii., xix., xx., in which the same spherical magnet NO was used, as in fig. 26, p. 274 ; for in experiment xviii., a mass of iron of intermediate magnitude was attracted, at the point of contact, with a force of 1312 grains. The iron block however which was much heavier, and was used in experiment XVII., was attracted with a force of only 720 gr., and consequently less than the iron used in experiment xviii. But the smaller mass of iron, which was used in experiment xix., was thicker than the iron used in experiment xx., which consequently, when in contact, was attracted with a force 574 gr. In order to further confirm this result, I hung from a beam a piece of iron which was much smaller; namely, the steel pyramidal foot of a common compass, the sharp point of which, when in

immediate contact with the pole of the round magnet, was attracted with a force of 20 gr. I then changed the position of this steel foot, so as to touch the same pole of the magnet with its obtuse end; and in this case it was attracted with a force of 224 grains, and consequently much more powerfully than any of the iron used in experiments XVII., xviii, XIX., XX. This result is further confirmed by the two experiments made with the iron filings, as in cases XXI. and XXII.; for the larger quantity of filings was attracted at the point of contact with a force of 650 grains, and the smaller quantity with a force of 710 grains. But a much smaller quantity of filings left in the box was attracted with a force of 315 grains; whence it is manifest that there is a determinate dimension of iron upon which the magnet acts with the greatest force, and that upon any larger or smaller mass of iron it operates with a less degree of force.

“ From these experiments, I think, may be elicited the best method of arming a magnet so as to enable it to carry the greatest weight. We have only to ascertain by weighing, what is the mass of iron upon which it acts with the greatest force ; and then to make an armature of the given thickness. From this corollary it also follows that the magnet does not attract the iron with a force of the general law of attraction by which all bodies attract one another; for suppose that in equal particles of iron there is innate the same force of attracting the magnet, then the degree of attraction in the mass of iron is as the magnitude of the mass, and therefore a larger mass ought to be attracted by the magnet more strongly than a smaller. But the experiments show the result to be utterly different, and that a larger mass is attracted more feebly than a smaller; we therefore infer that the action of the magnet arises from a cause different from that of the universal law of attraction ; as I will endeavour to show more at large by other arguments in the sequel.

“ *Corol.* 3. The magnet does not act upon iron at the same

distance as two magnets act upon each other. For if we examine experiment 1. we find that the larger spherical magnet operated upon the smaller at a distance of 5 inches and 10. lines; in experiment 11., at a distance of 9 inches; in experiment in., at a distance of 12 inches; in experiment V., at a distance of 18 inches; but in experiment xviii., the same magnet acted upon the iron at a distance of only 3 inches and 10 lines, as also in experiment xix. and xx. ; and at 4 inches in experiment xxi. From these experiments we derive abundant evidence of our corollary. I wished, however, to obtain further confirmation, so I took a needle free to rotate, commonly called a mariner's needle, which had not been rubbed upon the magnet, and I observed at what distance from the magnet it began to be rotated by motion of the magnet. I next rubbed the needle against a magnet, till it became impregnated with magnetic force like the magnet itself. This needle when replaced upon its pivot, was disturbed at a distance of 4 feet from the spherical magnet NO ; while in the former case, it would not turn when at a distance of only 9 inches. This corollary therefore is sufficiently proved ; it is also evident that a magnet emits from itself a force to a greater distance than pure iron does ; and that the latter throws out its forces to a greater distance after it has touched the magnet.

“ *Corol.* 4. These experiments have all been instituted to ascertain the proportion between the attracting force of the magnet and the distances. If now we cast our eyes over experiment xvii., going on from the distance of 12 lines to that of 3, we shall observe that the numbers which express the amount of attraction are almost in the inverse ratio of the distances; but that from this proportion the attractions observed at smaller and greater distances deviate; for if we begin our calculation from the distance of 12 lines, and thence proceed to a smaller distance, we shall find the consecutive numbers to be in the inverse ratio of the distances.

Distances in Numbers from		Ditto from		Distances in Numbers from		Ditto from	
Lines.	Calculation.	Observation.		Lines.	Calculation.	Observation.	
12	= 35	35		7	— 60 .	66	
11	= 38A ..	37		6	= 70 .	76	
10	= 42 ..	43		5	= 84 .	96	
9	= 46f ..	47 •		4	= 105 ..	109	
8	= 524 ..	57		3	= 140 .	131	

“If, at the other distances, the numbers arrived at by computation agreed, as accurately as these, with the numbers which are furnished by observation, I should not hesitate to affirm that the forces of the magnet which attract the iron were in the inverse ratio of the distances; for the small discrepancy between the two classes of numbers, one from calculation, the other by actual observation, would not prevent us instituting this as the real proportion. For all physical experiments are of such a kind as seldom to correspond exactly with the results of calculation. But we find that in the smaller distances, there is 'much less agreement between the calculations and observations; for if we continue the previous proportion, the attraction at the distance of 2 lines ought to be 210 gr., and yet it was only 179 gr.; at the distance of 1 line, it would be 420 gr., and yet it was observed to be only 231 gr.; at the distance of J line, it ought to be 840 gr., when yet it was only 343 gr. Now whence does this discrepancy arise ? is it that, use what iron we may, it possesses a certain power of repelling the magnet; and which, when diffused only to a small distance, takes away a certain portion of the attraction upon which at a still greater distance there is no repulsive force to operate ? or does the repulsive force of the magnet itself give rise to this inequality of attraction ?

“ The other experiments, namely, XVI. and xviii., I likewise took under consideration, with a view to ascertain whether, at the distances of from 12 to 3 lines, there was any attraction in the inverse ratio of the distances; but in these cases I did not find the numbers obtained by calculation so nearly

approximating to those supplied by observation. The following are those obtained by observation in experiment xvi., compared with those derived from calculation :—

Distances in Lines.	Numbers from Calculation.	Ditto from Observation.	Distances in Lines.	Numbers from Calculation.	Ditto from Observation.
11 =	14	.. 14	5	30 $\frac{4}{5}$	. 44
10 =	151	.. 16	4 =	381	. 52
9 =	171	.. 17	3 =	51J	. 72
8 =	19J	.. 21	2 =	77	. 96
7 r=	22	.. 29	1 =	154	. 110
6 =	25f	.. 32			

“The attractions observed from 11 lines to 1, are greater than those indicated by the calculation; but at the distance of one line they are less; an irregularity which doubtless arises from the attracting and repelling force, both of which act simultaneously upon the iron, and disturb the constancy of the proportion. The following however are the numbers obtained from experiment xviii., according to the inverse ratio of the distances; in which the same irregularity occurs.

Distances in Lines.	Grains from Calculation.	Ditto from Observation.	Distances in Lines.	Grains from Calculation.	Ditto from Observation.
12 =	61 ..	61	6 =	122	.. 164
11 =	66*..	70	5 =	146	.. 201
10 =	731 ..	84	4 =	183	.. 229
9 =	81f ..	106	3 =	244	.. 285
8 =	91J ..	121	2 =	366	.. 361
7 =	1041 ..	140	1 =	732	.. 472

“ As far then as I may be allowed to conjecture, it may be said that the forces of magnets, which mutually attract and repel each other, are in the inverse ratio of the distances, or in a ratio very near to this; and because the magnets attract and repel each other simultaneously, the experiments recorded in chap. I. cannot but give the numbers which express the attraction in an inconstant proportion; since they by no means represent the attraction alone, or the repulsion alone ; consequently the forces of the magnets do not decrease in so

great a proportion as the duplicate or triplicate ratio of the distances, as some have thought.

“ *Corol.* 5. Moreover, from the foregoing experiments we ascertain that the attraction of iron toward the magnet is not proportional to the magnitude of the surface opposed to the magnet, but that here also we meet with a maximum and minimum. For in experiment xix., the surface F of the foot of the armature was turned to the magnet, see fig. 38, p. 295 ; the other surface of the iron, both upper and lower, not including the sides, was but small; yet the attraction took place at the same distance from the magnet, as in experiment XX., in which the surface of the iron on ABCD which was opposite the same magnet, both upper and lower, was as much as, nay, considerably more than twelve times larger. At smaller distances, however, the same iron which was used in experiment XIX., was attracted much more strongly than in experiment XX. ; as may be seen from a comparison of the tables; in which we observe that the smaller surface of the iron was attracted with greater forces than the larger. Still we cannot from this infer that the smaller the surface of the iron which is opposed to the magnet, the greater is the attraction ; for I have advanced other experiments, made with the iron foot of a compass, which showed the attraction of the pointed end of the iron toward the magnet to be smaller than that of the obtuse end. There must, therefore, be a surface of a determinate magnitude, and a determinate mass of iron, which will be the most attracted by the magnet ; while other surfaces larger and smaller than this, will be less attracted. From these experiments might be advanced various corollaries ; but it will be better perhaps to mention only those which are the most evident, and are established by many observations, rather than those which are derived only from some one or other particular observation.

“ *Scholium.* So far as I am aware, Francis Hawksbee was the first person to enquire into the proportion of the magnetic forces at various distances of the magnet from the iron.

His method, which was very different from ours, although it might not meet with the approbation of all, still deserves to be known, on account of the effects observed by its means. The description of it is to be found in the *Philosophical Transactions*, vol. xxvii., p. 506 ; or in the *Philosophical Transactions Abridged*, by H. Jones, vol. iv., part ii., p. 295.

“ This genius, so clever in mechanics, took a quadrant, the radius of which was 4 feet; this he placed upon the ground, and in the centre of it a needle free to rotate. This, when left to itself, stood in the quadrant at 0 deg. He then placed a magnet in a piece of wood, so that its pole lay in the same plane with the quadrant and the needle, and might be moved round the edge of the quadrant from one degree to another, and from one distance to another. The magnet was of an irregular figure, and weighed about 6 lbs. He made however the experiments with two needles ; one of which was 3 inches long, the other 6 inches; but he always found the shorter to be the better.

“ In the tables containing these experiments, we must observe, that the longer needle, at a distance of 9 inches, formed with the magnet an angle a little greater than the shorter needle did, at a distance of 3 inches. The shorter needle, at a distance of 9 inches, made an angle 9 deg. less than the longer at the same distance. These paradoxes, however, will be easily understood, if we consider the disproportion in the length of the needles ; for the point of the longer needle, at a distance of 9 inches, was nearer the magnet by one inch than the point of the shorter ; and the point of the shorter needle, at a distance of 9 inches from the magnet, was distant 5 inches more than the point of the larger needle, when the magnet was in the same degree of the quadrant. This disproportion, therefore, must be borne in mind. We must, moreover, observe, that the magnet, at the distance of 5 inches from the needle, made an angle of 2 degrees with one needle, and of 2 J degrees with the other needle; but at a greater distance the change in the needle

was not observable; so that the magnetic force extended itself to a distance of 5 feet, at which the proportions could be taken ; but at greater distances the force of the magnet was so feeble that no observation could be taken with certainty.

"SHORTER NEEDLE.				LONGER NEEDLE.			
Its distances from the Magnet in Inches.	Angles made by this Needle at the several distances in Degrees and Minutes.		Successive differences in Minutes.	Its distances from the Magnet in Inches.	Angles made by this Needle at the several distances in Degrees and Minutes.		Successive differences in Minutes.
3 ..	87	<i>r</i> > 0	.180	9 ..	87	„ 30	.345
6 ..	84	>> 0	.330	12 ..	81	„ 45	.570
9 ..	78	>> 30	.570	15 ..	72	„ 15	.1137
12 ..	69	>> 0	.735	18 ..	53	„ 20	.1100
15 ..	56	45	.795	21 ..	35	„ 0	.660
18 ..	43	>> 30	.630	24 ..	24	„ 10	.380
21 ..	33	>> 0	.540	27 ..	17	„ 50	.280
24 ..	24	<i>ft</i> 0	.360	30 ..	13	„ 10	.180
27 ..	18	0	.270	33 ..	10	„ 10	.130
30 ..	13	>> 30	.150	36 ..	8	„ 0	.90
33 ..	11	> <i>l</i> 0	.135	39 ..	6	„ 30	.75
36 ..	8	45	.105	42 ..	5	„ 15	.65
39 ..	7	>> 0	.90	45 ..	4	„ 10	.40
42 ..	5	30	.60	48 ..	3	„ 30	.30
45 ..	4	>> 30	.40	51 ..	3	„ 0	25
48 ..	3	>> 50	.30	54 ..	2	„ 35	.20
51 ..	3	>> 20	.20	57 ..	2	„ 15	.15
54 ..	3	0	.15	60 ..	2	„ 0	0
57 ..	2	» 45	15				
60 ..	2	>> 30	0				

"Now inasmuch as in these experiments we cannot observe with accuracy the distances of the magnet from the needle, the Royal Society requested the celebrated Dr Brook Taylor to undertake experiments relative to the magnetic forces in another and a clearer manner. This ingenious and eminent mathematician, therefore, placed a needle in the centre of the former quadrant; and the magnet, the axis of which lay in a



horizontal plane, he moved backward and forward from the needle in a line which was at right angles to the natural direction of the needle. Then measuring the distances by a line between the centre and the magnet, he was enabled to form the following table :—

Distances in Feet.	Variations of Needle in Degrees & Minutes.	Distances in Feet.	Variations of Needle in Degrees & Minutes.
1	81 „ 45	6	5 „ 35
2	58 „ 0	7	3 „ 30
3	30 „ 0	8	2 „ 20
4	16 „ 0	9	1 „ 35
5	9 „ 20		

“ These experiments were made with a most excellent magnet belonging to the Royal Society; but because in these cases there was not preserved a similar position of the line in which the magnet was moved toward the needle, though it was an indispensable requisite, we cannot conclude much from these cases, as indeed Whiston observes;<sup>1</sup> who therefore undertook the task of additional experiments. Indeed I think that by none of these methods shall we attain our object; as will be evident from the suggestion I shall make after noticing the observations of Whiston. I have thought it worth while to add the experiments of this very clever philosopher; because they were made with a magnet and iron first impregnated with magnetic force. This investigation therefore was altogether different from our own ; for I used either two magnets, or a magnet and pure iron unimpregnated with any magnetic force. Whiston took two mariner’s needles, balanced on their pivots; one of which was 4J inches, and the other 4 ft. long; also a spherical magnet 2A inches in diameter. The south pole of this magnet he always opposed to the northern points of the needles, by moving the magnet toward the needle in such a manner that the latter formed a right angle with the directive line of the

<sup>1</sup> *Longitude and Latitude Found by the Inclinatory Needle.* London, 1721, p. 14.—Tt s.

magnet. He then measured the chords of the arcs in which the needle declined from its natural direction : the lengths of which he assumed as the quantities to express the attractive forces. Instead of the chords he substituted the sines of half of the arcs; and then he arrived at the following results:—

Distances in Inches.	Degrees of Declination.	Sines of Half the Arcs.	Distances in Inches.	Degrees of Declination.	Sines of Half the Arcs.
3 .	0 .	0	27 .	2 .	•0174
6 .	0 .	0	30 .	11 .	•0160
6J .	90 .	•7071	33 .	li •	•0131
9 .	27 .	•2334	36 .	•H •	•0109
12 .	13 .	•1132	39 .	<sup>5</sup>	•0073
15 .	9} .	•0848	42 .	•I	•0065
18 .	6f .	•0588	45 .	<sup>0</sup> K	•0058
21 .	.	•0392	48 .	•i •	•0044
24 .	3 .	•0262			

“Let us now examine the numbers which represent the distances and the sines which correspond to them; *e.g.* the sine '2334 answers to the distance of 9 inches, and the sine \*0588 to the distance of 18 inches. These numbers expressing the sines are to each other exactly as 3|4f to 1, or nearly as 4 to 1 ; that is to say, in the inverse duplicate ratio of the distances. The sines answering to the distances 12 and 24 are T132 and '0262 ; which are one to another, as 4r<sup>r</sup> to 1 ; consequently these are reciprocally to each other in a greater ratio than the former. The sines answering to the distances 15 and 30 inches are '0848 and '0160, which are to each other as SA to 1. The sines answering to the distances 1\$ and 36 are \*0588 and \*0109, which are as 5t A to 1. The sines answering to the distances 21 and 42 are '0392 and '0065, the proportion of which is 6 A to 1.

“ From the foregoing account it seems we must infer that the proportion is exceedingly inconstant; being sometimes less than a duplicate ratio, sometimes a little greater, sometimes much greater. Whiston however alleges that the ratio-

which obtains is the sesqui-duplicate; since in experiments of this kind a perfect geometrical exactitude cannot be obtained.<sup>1</sup> And this indeed we should grant, were the allowance required for this inequality not too great, as appears here to be the case; for the discrepancy is too considerable, since the experiments in one case give the proportion of \_\_\_\_\_ to 1, and in the other case of to 1 ; so

that these two must be reckoned as one and the same ratio. I do not see therefore why we should not confess that there is no constant ratio, rather than strain the experimental results to discover the existence of a ratio where nature denies it.

“ In this method, however, of ascertaining the magnetic forces, a difficulty is latent. For the magnet or the needle is acted upon by two forces distinct from each other; the one attractive, the other directive toward certain poles of the earth. In this experiment the needle is pointed by the directing force toward these poles. When the magnet is held to the needle at different distances, and deflects it from its previous direction, then by its attractive force it acts upon the directive force of the needle and deflects it, until the directive force, which acts upon the oblique position of the needle, finds its equilibrium with the attractive force of the magnet. Consequently we cannot, in this way, detect the quantity of the forces in the magnet and needle mutually attracting each other; but only something very different. For let us conceive a needle, free to rotate, fixed upon its pivot, placed in the middle of a current of water, and observing a direction in agreement with that of the current; let us also conceive that the point of the needle, by means of a string attached to it, is drawn sideways toward the bank in such a manner that the rope is always perpendicular to the needle ; in this case, if the direction of the needle be made angular, not only does the string, drawing with power, act upon the needle, but also upon the current; and has to overcome the force of the current running against it sideways and propelling

<sup>1</sup> Whiston's *Longitude and Latitude Found*, p. 18.—Trs.

it in a right line according to the determination of its course ; the force of the pressure of the stream being the greater in proportion to the opposition of the direction of the needle to the current of the stream. The force drawing and inflecting the needle acts here, therefore, upon the needle and upon the directive course of the current at the same time, and not upon the needle alone ; inasmuch as it is now only a body to be moved. In like manner a needle, free to rotate, rubbed upon a magnet, is driven by the universal directive force toward the poles of the earth; and upon this directive force as well as upon the needle, the magnet in our experiment acts with its attractive force; just as in the instance above cited the power by means of the intermediate string draws the needle in the stream. It is by this directive force that the magnet influences the equilibrium at different distances, and at the various oblique positions of the needle. From these experiments, therefore, we cannot infer with what force the two magnets are made to approach one another, or a magnet to a needle and to iron, solely by the attractive force. Still these experiments are not without their utility ; because, supposing the needle capable of turning upon its pivot without friction, they show that the attractive force of the magnet acts upon the directive force, at stated distances, according to the ratios above exhibited; and when the attractive force of a magnet

Fig. 39.

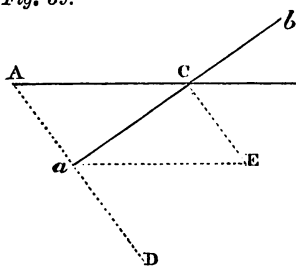

is known, then we may ascertain the amount of directive force at any angle of the needle's obliquity, by the common rules of mechanics.

Thus in fig. 39, let ACB be a needle whose axis is in C ; which, by the action of the directive force in the line BCA, is kept in the same position. Suppose the needle to be drawn by a force D, into the oblique position aCb, so that the angle CaD is a right angle. Let any straight

line  $Ea$ , be drawn parallel to  $AGB$ , which indicates the directive force ; and let  $EC$  be drawn at right angles to  $aC$ . Let the directive force be resolved into one perpendicular to \_\_\_\_\_ the needle, or  $EC$ , and into another  $aC$ ; then  $EC$  will be directly opposite to  $aD$ , the direction of the power  $D$  ; and the three sides of the triangle  $EaC$  will by their magnitudes express the forces which we find here.  $CE$  will denote the force of the drawing power  $D$  ;  $Ea$  or  $AC$  the whole of the directive force ; and  $aC$  part of the remaining directive forces. The length of the needle therefore  $aC$  being known, as also the angle  $EaC$ , and the quantity of the attractive forces or  $EC$ , then  $Ea$  or  $AC$  is found, that is to say, the amount of the directive force.

“ In the course of my reflections upon the universal directive magnetic force, by which the needle is directed and depressed below the parallel of the horizon in these regions of Europe, as will afterwards be evident when I come to treat of the inclination of the needle, I began to doubt whether in the experiments in which I had hung from the beam one magnet above the other, there might not have arisen a certain depression of the magnet toward the horizon by reason of the universal directive force, and whether the exact measure of the attractive forces might not thus be disturbed. My doubts however vanished upon considering that the directive force thus depressing the magnet produced, as it were, a certain portion of the weight of the magnet; and inasmuch as this force, together with the weight, was brought by weights into a state of equilibrium before the experiment was begun, and always remained equal, it could not possibly have disturbed the observations that were made with respect to the attractions.” (*Op. cit.*, p. 35-55.)

## CHAPTER VII.

### THE INFLUENCE OF A MAGNET UPON HEATED IRON.

#### A PRIORI OR FROM FIRST PRINCIPLES.

The magnet acts with less power upon white hot or heated iron than when it is cold ; and its influence upon heated iron decreases as it grows hotter. The actives themselves, which constitute the bright and living fire, can in no way impede the motion or gyration of the magnetic element; as will be shown in our theory of the fourth and fifth active. For the fire, which is luminous and acts by flame, consists in the motion of actives highly compounded; which in the volume of the particles of the most subtle magnetic element can fully perform their gyres without restraint or hindrance; just like masses, or highly compound bodies, in the air or ether. We shall however treat of this in the sequel. Meanwhile we premise that neither the flame of fire, nor heat, can possibly interfere with the gyration of the vorticles or effluvia ; all that it does is to induce, by reason of the heat, a motion of the parts of the iron. For as we have already stated, the attractive force of the iron and magnet consists in this; that the magnetic force is capable of travelling from its own sphere into the iron, in a state of regularity, so that the iron can have all its individual parts kept in the same current ; and this supposes a state of rest among the parts themselves. If, however, the parts are in a state of interior motion and perpetual transference from one place to another, or from one position to another, it cannot be surprising if also the sphere

of the vortices which penetrates the iron cannot so fixedly and so firmly keep the several parts attached to itself ; and if, instead of parts which are at rest, it should assign to itself such as are mobile, and so should act not upon a firm and steady but upon a moveable structure; in this case the magnetism comes to be diminished in proportion to the degree of heat. We may see what is the state of white hot iron, when watching a melted mass poured fresh from a furnace in a smelting-house. In one place we perceive little rivulets running, and masses of *scoria*, or parts that offer little resistance to igneous action. In another may be seen bursting forth extremely white or blue sulphurous flames ; in another living fountains and torrents of sparks vibrating round one another and darting out into the air; so that the whole mass is interiorly in most rapid motion; for the fire boils up in its very inmost parts, or burns in veins of the most diversified nature ; there being in iron parts of different kinds, one that melts and boils, another that separates into pieces, burns, and consumes. These, when gathered into one body, are condensed ; so that as the poet sings,

“When, shut in furnaces, rages the devouring fire.”<sup>1</sup>

In a word, since fire destroys all things from within and disturbs the interior parts of the iron and turns them from place to place, we are not to wonder if the magnetic sphere which penetrates the iron should have to arrest and detain not the parts which are fixed, but those which are free and in motion ; which, if they flow with perfect ease, cannot cohere with the sphere of the magnet; the particles eluding and, as it were, avoiding the magnetic force and bond. Consequently the magnet is no longer able to attach them to itself, as it can in the case of cold iron ; the parts however which actually become affixed to the magnetic sphere and current, adhere to it according to the extent of heating.

<sup>1</sup> Virgil's *Georgica*. Lib. iv., l. 263. Translated by J. Lonsdale and S. Lee.—*Trs.*

## MUSSCHENBROEK'S EXPERIMENTS.

## "EXPERIMENT XXIII.

“ An iron block, weighing 5 lbs., was placed in a brass scale which was hung by chains of brass attached to the beam of a balance, and was brought into equilibrium by weights placed in the opposite scale ; after this it was submitted to a strong fire until it grew red hot, but not so as to emit sparks. It was then replaced in the scale, beneath which the larger spherical magnet NO (fig. 26. p. 274) was placed at a distance of exactly 2 inches ; upon which the heated iron was immediately drawn down by the magnet. The attractive force was then investigated, by placing weights in the other scale so as to restore the equilibrium. During the progress of cooling, the attraction of the magnet more and more increased, reckoning from the period of the utmost degree of heat down to that in which the hand could scarcely endure contact with the iron, when the attraction became equal to 3 grains ; but on the iron continuing to cool down to the same degree of temperature as that of the atmospheric air, the attraction further increased by 4 grains; so that the whole difference of attraction between the greatest degree of heat and the atmospheric temperature, was, at the distance of two inches, equal to 7 grains ; while the attractive force of this magnet, as exerted upon the same iron when cold, was equal to 16 grains ; which had consequently decreased to almost half, when the iron was at its highest degree of heat. After this the experiment was repeated with the same magnet and iron, but at a distance of one inch. The iron, which as yet was cold, was attracted by the magnet with a force of 61 grains; but when heated to its highest degree, with a force of 26 grains; so that the difference of attraction was 35 grains. In this experiment the iron was hotter than in the former, and the force of the magnet therefore had here



decreased. Should these operations appear to any experimentalist to be too laborious, we shall show by an easier method, that the magnet does not attract or lift red hot iron so readily as cold; for whether it is armed or unarmed, if as much weight of cold iron is attached to it as it can just lift, and the iron is afterwards heated and applied, the magnet cannot sustain it.

“ It was formerly observed by the celebrated Boyle that a magnet did not influence another heated magnet with as much force as when it was cold. He kept three loadstones of compact substance in the fire, until they had become red hot; he then put them upon a silver plate; next, placing beneath them another loadstone, the latter attracted the heated ones, but only feebly, and the attraction continually increased as the loadstones became colder.<sup>1</sup>

“ I cannot therefore pass over in silence the error of Kircher, who in *Magnes ; sive de Arte Magnetica*, Colonise Agrippinse, 1643, lib. i., theorema xxxi., p. 140, affirms, with respect to the magnet, that the influence of the magnet upon cold iron and heated iron, is precisely the same. This great man appears to have fallen into this error in consequence of conducting his experiments in too rough a manner, by applying the heated iron only to an armed magnet ; in which case it is indeed attracted, but never so strongly as iron in a perfectly cold state.

“ May we not understand from this how it is that the magnet attracts iron, impregnated with a summer temperature, with less force than when it possesses a winter temperature and is more condensed ; as I have noticed in experiment ill. ?

“ In chap. V. of this dissertation it will be shown that all iron is impregnated with a magnetic force, when it is cooled\*; also in chap. III., that fire expels the same force, or a still greater, communicated from the magnet to the iron. Therefore iron at the whitest heat, and deprived of a great part of its attractive virtue, cannot be attracted by the magnet with

<sup>1</sup> See his *Philosophical Works Abridged*, by P. Shaw, vol. i. p. 503.—Trs.

as great force as cold iron endowed with a magnetic force. Besides, the vibratory motion with which the heated parts of the iron are agitated, impede the magnetic forces, and render them inefficient. We might here further enquire as to the manner in which the fire influences these forces; but because I have not yet explained the manner in which these forces are acquired, whether they are material or whether they are of a different character, it may be well at present to say no more on this part of the subject, but rather first to employ ourselves in investigating these forces." (*Op. cit.*, pp. 55-56.)

## CHAPTER VIII.

### THE QUANTITY OF EXHALATIONS FROM THE MAGNET, AND THEIR PENETRATION THROUGH HARD BODIES, ETC.

#### A PRIORI OR FROM FIRST PRINCIPLES.

The magnetic sphere can flow freely not only through volumes of the elements, such as air and ether, but also through water and flame ; in like manner through hard bodies, whether of wood, stone, or metal. The magnetic element, because it is the most subtle and the first, permeates, with a current perfectly uninterrupted, the interstices of every succeeding and grosser element. For both the ethereal and the aerial particles are surrounded and pressed by them on every side, and are thus kept in their figure, arrangement, and motion. The densest liquids are encompassed by ethereal particles, which are able to perform their motions and gyrations through the interstices of these liquids naturally and without obstruction. They can likewise permeate flame, which consists of the actives of the fifth element. But upon this subject a clearer idea will be conveyed in the third part of our *Principle*^ where we shall also furnish the theory of each element. It will be sufficient here to state, by way of anticipation, that these are the first and therefore the most subtle elements in the mundane system, and consequently can flow with a perfectly free course around the larger elementary particles, which are derived from them ; and consequently also through the structure of harder parts, such as stones and metals; for since these can be penetrated not only by the ether, by hot water, by different kinds of solvents, by salts

and mercury, much more may they be penetrated by the minute volumes of the most subtle element which surrounds the subtle ether or fills the spaces between the particles of ether. With regard to the spaces between the closely packed parts of metals and stones, the reader is referred to those authors who have proved the fact by innumerable experiments. No one, therefore, can deny that these spaces are wide enough to receive the element of which we are speaking, for it is most subtle; especially when we consider that it fills the spaces between the particles of ether, as also the ethereal and aerial spaces in every individual particle, and that the ethereal particles are themselves of such a nature as to be capable of permeating the pores and interstices of harder bodies.

Nor do the effluvia which permeate the texture of harder bodies anywhere lodge, impinge against, or become affixed to, any of their parts or surfaces ; but flow with perfect freedom throughout the entire mass, without contact, collision, or impact. For the effluvia lie enclosed within their own vortices ; for they are centres, and a centre cannot pass out of its own vortex, or beyond its own peripheries; and without a vortical gyration, it never flows at all; hence it cannot run or strike against any parts of a hard body ; for the circular motion of a vortex defends its own central effluvia from any incursion or conflict. Wherever a vortex runs, there also follows the effluvia or centre; wherever the vortex is repelled there also the effluvia is repelled ; from every hard part the effluvia is kept at a distance by the vortex; thus does it reside in the centre, free from every casualty so long as its motion remains in the vortex; hence it cannot strike against or become fixed to any surface; nor can it come into conflict with effluvia of any other kind ; but as the element is permeable, so also it follows is the effluvia itself.

2. Nor can the magnetic sphere conjoin with itself any other kinds of metal except iron and steel, or such as partici-

pate of iron. For the magnetic sphere can only act upon such bodies as are similar to itself and possess a similar motion among similar elementary particles. Now in metals of various kinds, effluvia nowhere occur similar to those which are in iron, which throngh the interior structure of its parts, and occupy also the space around it to some distance; whence at its own pleasure the magnetic sphere can turn them into the direction of its own current, either wholly or in part.

3. By a larger quantity of outgoing effluvia, the magnetism and power of attraction of bodies are increased. For the larger the quantity of effluvia that goes forth, the more vorticles and spiral gyrations are there to flow round about; and the more numerous these are, the more strongly do they become linked together by spirals of greater curvature, and thus the stronger also is the magnetic sphere, according to the theory already presented ; so that what principally contributes to the magnetic force is the quantity of effluvia, which never in any respect destroys or enfeebles the connective power.

Still, however, there is no need that a wave or tide of effluvia should perpetually pour forth from the magnet, so that the magnetism must be renovated and restored by a continual influx and efflux of effluvia. For the sphere itself is capable of subsisting around the magnet without any considerable quantity of effluvia, or any considerable additional supplies ; since the magnet floats in its own sphere, and constitutes, together with its sphere, as it were, one contiguous body. The sphere itself remains attached to the magnet by the gyrations of the individual parts, or by vorticles. Those effluvia only which are the more remote are capable of escaping from the sphere, and whose vorticles are not linked with the adjacent axis at an angle of 45 degrees. Now since the sphere thus formed, and having its parts reciprocally held together, cannot stray from its own magnetic body, it follows that there is no necessity for the magnetism to become constantly renovated by any new and considerable wave of effluvia.

### 350 *PENETRATION OF EFFLUVIA THROUGH METALS.*

4. No increase of weight is produced in iron by rubbing it against a magnet; but the smallest parts of the iron are drilled into a straight line, and, partly loosened by rubbing against the magnet, are only turned round and brought into a definite order. And thus it is that magnetism is communicated to iron ; therefore the magnet experiences no loss of its forces, since one magnet alone would suffice to render magnetic all the iron in the world, as is clear from what we have already said, and as will further appear in the sequel.

5. He who wishes to form and build up principles by geometrical and mechanical methods, and afterwards to confirm them by experiment, must not assume and refute the opinions and arguments of others ; but must only present to notice causes, and demonstrate the connection between first principles and experiments. Unless there is a geometrical and mechanical connection between first principles and actual experiments, then are these principles but mere hallucinations, mere dreams of the brain. If however there is this connection, then causes will arrange themselves simultaneously according to this connection, and all arguments and opinions to the contrary are thus neutralized and silenced ; so that to employ ourselves in refuting them is only to spend our time and trouble to no purpose. They are sufficiently refuted of themselves, if the causes and their mutual connections are demonstrated and acknowledged ; in these it is that the truth consists ; and truth is one and incapable of continuing in any other than its own proper order of connection. Consequently, wherever I see that our talented author, Musschenbroek, seems to impugn by arguments, however ingenious, the doctrine of the magnetism of effluvia, I can have no wish to oppose him; but shall here give a literal quotation of his arguments; particularly since his opinion is so far also my own, that mere effluvia cannot of themselves present any magnetism ; and would be entirely devoid of it, were it not for a circular and vortical motion.

musschenbroek's experiments.

“EXPERIMENT XXIV.

“ Because many of the learned have been of opinion that the effects produced by magnets depend upon certain subtle effluvia continually going forth on all sides, or upon an ethereal fluid everywhere surrounding the magnets, pressing, or propelling the magnets toward one another, iron, or other bodies which are attracted by them, I have made it my business to enquire carefully into the arguments on which this opinion is founded. Upon investigation I find that there appeared to be either no arguments, or such as were so feeble that I might with justice be accused of rashness were I, without . some better reasons, to maintain that a magnetic effluvium, or an ethereal fluid, was the cause of magnetic phenomena. After commencing my task and going in search of the effluvia or ether, I could not meet with any experiments which provided the slightest evidence of their existence; on the contrary, I became possessed of data which clearly convinced me that magnets are not controlled, nor can be, either by effluvia or by ether. To make this clear, let us suppose that there are effluvia which proceed from the magnet, and which by their outflow are the cause of repulsion, and by their inflow, the cause of attraction ; and let us imagine a magnet such as in fig. 40, very delicately suspended from a beam; and another magnet placed under it upon a table. From each of these let the effluvia pass out and return freely, and let the magnets attract each other with their greatest force. Now let us conceive a solid and dense body placed between them. Will not the effluvia of each magnet run against it ? will they not be intercepted and their direction changed ? and will not the attraction and repulsion therefore be destroyed ? I know indeed that it may be replied that all

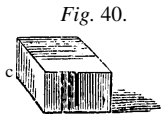

bodies are exceedingly porous ; that the effluvia are so extremely subtle that they can easily permeate the pores; and that attraction and repulsion may in this case be observed just as if nothing were placed between the magnets ; we reply that all firm bodies possess pores, yet still they are composed also of many solid parts, impenetrable, and hence interceptive of the effluvia which move against them. The heavier bodies are, the more solid are they and the less porous ; they will consequently intercept much more of the effluvia of other bodies, however subtle the effluvia may be. Odours do not pass through the pores of glass, metals, stone, and other solid bodies. Light, which is the most subtle fluid we know, falls upon glass, metal, quartz, water, oil, and every other body. A great portion of it is reflected from the solid parts; another portion passes through the pores : so that after its transit through transparent bodies, it is considered to be much rarer, not shining so brightly; and much rarer still is that which passes through the pores of more opaque bodies, in those cases in which it is able to pass through. Is not a considerable portion of light intercepted by the atmosphere, by light vapours, mists, or extremely rarified clouds ? But the subtlety of fire perhaps does not much yield to that of light. Hold over it a very sensitive thermometer, and the fluid will be observed to expand immediately. Between the fire and the thermometer place a piece of glass, a layer of metal, of paper, of wood, or any other firm substance ; and by all these the fire will be intercepted. For at first the fluid will not ascend in the thermometer; then after a lapse of time it will be observed to expand slowly, and but little. Remove the interposed body, and the fire, conveyed to the fluid without hindrance, will suddenly expand it considerably. Even the most highly volatile spirit that art ever prepared may be so confined in glass bottles as not to pass, or but little and slowly, through their pores : the air may be so enclosed by a solid body as either not at all, or with great difficulty, to pass through its pores. In general, I would say, that there



is no kind of body known which may not wholly, or for the greater part, be confined by metals, glass, or other solid substances. If, therefore, metals and other very solid bodies may intercept the particles constituent of odours, all volatile spirits, as also both fire and light, either entirely or for the greater part, will they not in some measure intercept the magnetic effluvia in such a manner that the effluvia will not be so plentiful beyond the intervening obstacle as when the obstacle is removed ? Do these effluvia pass through the most solid bodies with the same ease as if nothing were there ? No one, I think, who reasons from experiments compared with one another, or forms clear mechanical conceptions of bodies and their structure, can possibly adopt this opinion, for \* it rejects all analogy, and assumes impenetrable bodies to be perfectly penetrable. We must, therefore, maintain, that if effluvia are perpetually given off by a magnet and also attract another magnet or iron, these effluvia must be intercepted by any metallic, vitreous, or other perfectly solid body ; and that one magnet could not then exercise upon another so great a power of attraction as if both were opposed to each other at the same distance without any intervening obstacle. If, however, both have the same power of attraction when there is an obstacle interposed as when there is none, then are there no effluvia, but the magnetic phenomena result from another cause. Let us, therefore, betake ourselves to experiments, and ascertain whether very solid bodies placed between two magnets, take away, diminish, or alter the attracting forces, or whether they leave them entire.

“1. A magnet H (fig. 26, p. 274) was hung from the beam, beneath which, If inches distant, was placed the globe NO ; and the attracting forces were then measured. Between the magnets was interposed a mass of lead, rather broad but only If inches thick; in this case the attracting forces of the magnet remained the same as before. The lead was then removed, and again interposed as before; but the attraction always continued the same.

“ 2. In the place of lead there was taken a block of tin 1 f inches thick. When this was placed between the same magnets, no increase, decrease, or difference in the forces was observed. Nor were they affected, even in the least, by the interposition of several globes of tin possessing a greater thickness; the forces remaining the same as if nothing was interposed between the magnets.

“ 3. A mass of copper 1 inch thick and several inches wide being interposed, produced no change in the attractive forces; whether interposed or not, the attraction remained the same.

“ 4. Coins of gold or silver interposed, produced no difference in the attractive forces.

“ 5. Lest the thinness of the metals should be alleged as the true reason that the transmission of the magnetic forces was unimpeded, we took a block of lead 1 foot thick, as also a more powerful magnet than the one we had used in our former experiments. This magnet was placed upon a table,, so that the other H hung by a string might be made to descend, by the increase of the attractive forces. Yet even in this case, the attractive force was observed to be the same when the lead was withdrawn, as when it was interposed between the magnets.

#### “EXPERIMENT XXV.

“ In the course of the foregoing experiments, I began to consider whether the magnetic effluvium intercepted by the metals, did not spread itself along their surface ; and whether after having reached their edges it did not turn in its course and surround the magnets, going equally upward and downward, and thus depressing the suspended magnet toward the lower, just as if no metallic body intervened. In order to satisfy myself upon this subject, I had three metallic boxes made ; one of lead, another of tin, a third of copper, to enclose the magnet used in experiments vn. and vm. The magnet was then placed in one of the boxes and the lid of the-

box was soldered down ; by this means the stone was secured within the metal. The box was then hung from a long cord fixed to the beam, as in the foregoing experiments; and on being lowered to different distances, it was attracted by the forces exhibited in the following table. It is to be observed that the same magnets were employed as in experiment vil.

Distance of Magnet in Lines.	Its Attraction in the Leaden Box given in Grains.	Ditto in the Copper Box in Grains.	Ditto in the Tin Box in Grains.
12	= 57	57	57
11	= 62	63	63
10	= 66	65	66
9	= 70	70 ..	71
8	= 79	78 J ..	79 ~
7	= 83	83	83
6	= 91	90	90
5	= 101	101	101
4	= 115	113	114
3	= 124	114	124
2	= 148	148	148
1	= 168	168	168

“ By comparing these three tables with one another, and with that of experiment vn., we see that there is a very close agreement between the attractions at equal distances. With regard to some of the numbers which differ a little, and consequently represent some variation in the attraction, we must observe that a magnet hung by a cord can never, in such a variety of experiments, be so accurately manipulated so that the same points in the upper magnet shall always oppose the same in the lower ; a fact which must necessarily

- cause some variation in the attraction. I wish, however, to exhibit faithfully the observations, together with their irregularities, rather than to correct or to alter any; for if any one will but repeat the experiments, he will soon discover that, use what skill he may, he cannot always find at all distances the same mutual attraction between the magnets; because when, by the turning of the string HG, the magnet

H is in the slightest respect made to change its former position, another and a different attractive force toward NO is immediately observed.

“ From these experiments, therefore, it is evident that metals do not retard the magnetic forces, diminish, nor disturb them ; but that, in respect to magnetic effluvia, they may be what vitreous and transparent substances are in respect to light, and which transmit through themselves the greatest quantity of light. It occurred to me, therefore, that similar experiments might be performed with other solid bodies, which might have the same relation to effluvia as opaque bodies have to light. With this idea I enclosed a magnet within a vessel of Chinese porcelain; and after this, in another vessel of glass; and in these two experiments the attractive forces were submitted to examination in the same way as before; but neither vessel offered any obstacle to the magnetic forces, nor occasioned any decrease in them ; inasmuch as the forces traversed with the same facility as if the magnets faced each other without any intervening body. The magnet was lastly placed under Boyle's receiver, from which the air was withdrawn as far as possible by means of the pump. Another magnet outside the receiver was then hung from the beam, and on being lowered to different distances was attracted by the same forces as in a former experiment when both magnets remained in the open air. I am aware indeed that the great Boyle has referred, in the case of a similar experiment, to a different result in his *Continuation of New Experiments Physico-Mechanical*, Part i. Oxford, 1669 ; where he says, that he loaded a magnet with as much iron as it could lift, and then having hung it from a hook in the receiver, exhausted the air; on doing this the magnet for some time continued to sustain the iron, but afterwards let it fall,<sup>1</sup> (pp. 105-106); 'a fact which would seem to show that

<sup>1</sup> Musschenbroek has misunderstood his authority here. Boyle does not say that the iron weight fell from the suspended magnet when the air was exhausted from the receiver, but, on the contrary, he had taken precautions that the motion of pumping should not shake the weight from the magnet, and when

in a vacuum the magnet possesses less force than when in the open air. The fall of the iron, however, was occasioned, I suspect, rather by a concussion of the magnet, which it is scarcely possible to avoid while pumping. Besides *in vacuo* the iron mass is heavier than in air; a fact which may itself have contributed something toward producing the fall. Moreover, it is easily demonstrated, that, in an exhausted receiver, the magnet influences the needle with perfect ease, if both are enclosed in the same receiver; for after the air is exhausted and the magnet is moved round the needle, the latter follows the motion as faithfully as the most obedient magnet, and is sensitive to the slightest movement; a fact that Boyle himself proved by an experiment differing but little from our own.

“ Now both from our own experiment and from that of Boyle, it is evident that in a rarer air the magnet does not sustain a greater weight than it does in a denser. Therefore I consider erroneous the observation of Hartsoeker, in his *Eclaircissements sur les Conjectures Physiques*, that the magnet lifts a greater quantity of iron in proportion to the greater lightness of the atmospheric air and the depression of the mercury in the barometer. It would be safer to conclude, that neither the rarity nor the density of the air makes any difference in the attractive forces; that the vacuum of Boyle neither increases nor decreases the forces. I have, therefore, been surprised at the error of Sturm, otherwise a person of great judgment, who was of opinion that the magnetic phenomena were produced by the elastic air, and that it is by the pressure of the air that one magnet approaches another or iron :<sup>1</sup> an error, however, which has been admirably exposed by the celebrated Wolff.<sup>2</sup>

“ I am not the first person to note the penetration of the the air was exhausted “shaking the engine somewhat rudely, *without thereby shaking off the weight that hung at the loadstone*, the iron seemed to be very near as firmly sustained by it as before the air began to be pumped out.”—*Trs.*

<sup>1</sup> Sturm's *Physica Electiva*. Norimbergae, 1697-1722, vol. ii., p. 1117.—*Trs.*

<sup>2</sup> See his *Vernunfftige Gfedancken*, § 382. — *Trs.*

magnetic force through all bodies; but I am not aware that hitherto it has been shown that it remains precisely the same without any loss. Gilbert, in *De Magnate*, lib. ii., cap. xvi., mentions that its force passes through water, earthenware, and any crucible or other vessel; 'for,' he says, 'neither thick tables, nor pottery, nor marble vases, nor metals themselves, offer any impediment. No body, however solid, takes away or impedes its forces. Whatever substances are interposed, even though they be of the densest nature, as they do not take away its power nor obstruct its course, so neither do they in any manner impede, diminish, or retard it' (p. 83). Kircher, in *Magnes*, lib. i., theorema vii., p. 72, repeats nearly the same words. Schott in his account of Kircher, makes the same observation, in his *Magia Universalis Naturæ et Artis*, vol. iv., cap. iii., § 1, p. 245. Gassendi likewise confirms the remarks, in *Animadversiones in Decimum Librum Diogenis Laertii*. Lugduni, 1649, vol. i., p. 373. The Florentine philosophers ascertained from their own observations, from experiments made with the magnet, *Saggi di Naturali Esperienze fatte nell'Accademia del Cimento*, p. ccxviii., that the power of the magnet remained the same after having penetrated through mercury; through a wooden vessel filled with sand, or filings of any metal except iron; through solid blocks of stone, or marble; through fifty plates of gold placed one upon the other; through blazing spirits of wine. Wolff made the same experiments with a magnet, and noticed the same results: see his *Vernunfftige Gedancken von den Wirkungen der Natur*, § 382. Leeuwenhoek, in the *Philosophical Transactions*, vol. xix., pp. 512-518, has proved also that the force of the magnet travels through water.

“ Kircher, after finding that the force of the magnet permeates in this manner through all bodies, gives utterance to the following sentiments in opposition to Epicurus,<sup>1</sup> who maintained that circumfluent atoms, which also urged the magnet, were the causes of all effects:—‘How is it that a

<sup>1</sup> See *Fragmenta de Natura*.—Trs.

magnet of this kind can draw into iron the smallest corpuscles of atoms with equal facility and with instantaneous transition through the hardest and most solid bodies ? It is probable then that the circumpulsion which was not in the magnet, was only in the brain of Epicurus; and that hence was the occasion of an opinion so dissonant from fact.' *Magnets*, lib. i., par ii., p. 58. On the same rock have foundered many of our more recent philosophers; who have recourse to this or other fluids, or to corporeal effluvia of some kind or other, in order to explain the actions of the magnet. But there are other considerable difficulties with which hypotheses of this kind are pressed, beside those we have already adduced ; as will further appear in the sequel.

“ For let us suppose that there are effluvia or fluid particles issuing from the magnet, and which are corporeal; or, with Tachenius, that there are odours, for he maintains that the magnet attracts iron by an odour.<sup>1</sup> In this case, fig. 41, let

Fig. 41.

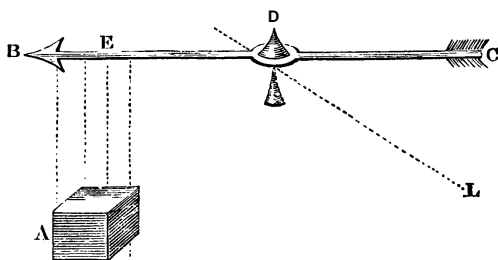

A be a magnet whose effluvia are carried in the direction E and F. Let BDC be a body extremely<sup>^</sup>mobile upon the pivot D, after the manner of a mariner's needle. Let BDC be made of any extremely dense metal; this will consist partly

<sup>1</sup> *Hippocraticcc Medicines Claris*. Francofurti, 1669, p. 256.—Trs.

of pores, partly of solid portions. Because the effluvia AE. strike against the solid parts of the metal BC (for some of them will necessarily do so), they will also put them in motion; so that the part BD will be raised to K ; and the part C lowered to L; and the elevation toward K will be the greater as BDC is the less porous. But an effect of this kind is never produced if BDC be a needle made of any other metal than iron ; for it remains perfectly still, whether the magnet be placed either above or below BDC. An iron needle alone moves when the magnet is placed at A. No one who has microscopically examined the solid structure of bodies, will maintain that all metals are so porous that effluvia may pass through them with perfect freedom; while, on the other hand, that iron is so solid, so little porous, as to receive all the action of the effluvia upon itself; and that this is the only reason why iron is moved and other metals are at rest. Nor can it be granted that the force of the effluvia AE is too feeble to move the needle BDC made of copper or of other metal; since a similar needle made of iron and placed in the same position, is moved by a magnet with a force equal to a weight of several grains.

“ Moreover, if effluvia proceed from the magnet A in the direction E, and meet the iron needle BDC, will they not repel it farther from the magnet toward K ? for as they move in this direction, so in the same direction they will move the needle. But if the needle, made of pure iron not yet imbued with magnetic force, is placed upon the magnet A, then it will not be repelled from it so as to cause it to recede, but be attracted by it so as to cause it to approach. This approach, therefore, requires as its cause, rather the effluvia which enter the magnet and which are carried down by the motion EA; but yet the effluvia which come from without toward a body cannot properly be called the effluvia of that body. We may hence conclude, that those philosophers who have deduced the forces of the magnet from corporeal effluvia, have not sufficiently taken everything into consideration.



“ Moreover, he who supposes that there is a fluid externally surrounding and approaching the magnet, and that this is the cause of the forementioned effects, will not be without inextricable difficulties. For let this fluid be supposed to be corporeal and carried in the direction EA towards the magnet, then will it propel the solid body BDC, whatever it may be, placed at a small distance from the magnet, toward the magnet, whether the body be made of copper or of iron ; for this fluid will necessarily meet the solid parts of copper in the same manner as those of iron. Yet experiments do not prove this to be the case ; the copper needle BDC remaining perfectly still, while the iron needle is attracted towards A.

“ Nor has the explanation of Gassendi any place in our estimation; he says, ‘ That the magnetic radii do not attract marble although they attract iron; neither do they attract straws or other lighter bodies interposed between them; since with the exception of iron and the loadstone, all other bodies possess neither reciprocal radii, nor that disposition of pores or interstices in virtue of which they refract rays and are themselves acted upon by them.’<sup>1</sup> But I would ask Gassendi, whether marble, straws, or other small bodies, do not possess solid parts. I grant that there are pores in them, formed in a manner quite different from those which are in iron; still the magnetic radii, which he supposes to be corporeal effluvia, will come into contact with the solid parts of the marble, however few those parts may be, and however rectilinear be the direction of the pores, if turned contrariwise to those of the iron. Therefore the radii must communicate some motion, however small, to the marble and the straws; yet on experiment no motion is perceived to be communicated either to the straws, or to the marble, or to other metals ; and therefore this opinion falls to the ground.

“ Moreover, I would ask why does the fluid move toward A. Is it due to the attractive force of the magnet? If so, then

<sup>1</sup> *Animadversiones in Decimuni Librum Diogenis Laertii.* Lugduni, 1649, vol. i., p. 385.—*Trs.*

will the mutual attraction of bodies toward each other be explained by another attraction equally obscure ? which is absurd. Moreover, why does the fluid act more strongly in impelling another body, the nearer it is to the magnet, unless it be that its motion is perpetually accelerated ? and yet what can be the cause of this accelerated motion, unless we suppose a magnetic attractive force acting with different intensities at different distances ?

“ Again, let there be a magnet at A, a bar of iron at E, and another at F ; and let both the latter move toward the magnet with a strong force; in this case the iron corpuscles, situated everywhere around A, will move toward the magnet; a movement which would prove that the fluid also on all sides moves toward the magnet, where this fluid remains; or does it issue again out of the magnet ? The patrons of this opinion may affirm that it does, as is evidenced by repulsion. But I wish them to know that the repulsion detected in our experiments is much weaker than the attraction ; as will appear to every one who compares our experimental results. In this case then the fluid will flow to the magnet in greater force and quantity than that with which it will issue out of the magnet. Consequently, in a greater or less time, the pores will become filled, and the magnetic force will cease. Yet we do not find this to be the case ; for after an interval of many years we still find magnets retain the same force.

“ Let us now suppose the iron at F to be fixed firmly upon a table; and a magnet to be hung from the beam at A. Let the fluid move in the direction FA, pushing the iron toward the magnet; and let this force between F and A be accurately weighed. Then immediately under the iron at F, let a cube of lead be placed, no matter how thick ; will not the cube in some measure impede the approach of the fluid toward A ? If not, we are compelled to suppose the lead to be so porous as to have no solid parts ; a position to which none will assent. But whether the lead be interposed or not, the action of the iron upon the magnet remains the same.

Consequently we cannot, without the greatest absurdity, suppose the existence of any such kind of fluid.

“ This hypothesis, however, of an external fluid, or of magnetic effluvia, will be further negated, and without difficulty, in the course of our ensuing experiments.

“EXPERIMENT XXVI.

“ Let a magnet and a plate or rod of steel or iron be very accurately weighed, apart from each other ; let the plate or rod be rubbed against the magnet. Let the weight of each be again determined, and in both cases the weight will be found to be the same.

“ The first person who tried this experiment was Norman. He took two or three long pieces of iron wire, which he had first weighed in a goldsmith's balance ; then having rubbed them against a magnet, he again weighed them and found the weight to remain the same. See *The New Attractive*, chap, v., p. 11. Gilbert made the same experiment: *De Magnete*, lib. iii., cap. iii., p. 123. Mersenne<sup>1</sup> and Gassendi,<sup>2</sup> ascertaining the weight of some iron before and after its application to a magnet (which they did by using the balance of a bullion-weigher), observed that the weight of the iron remained the same. Whiston, however, throws doubt upon the observation in his *Longitude and Latitude found by the Inclinary Needle*, p. 9 ; and affirms that the iron becomes lighter after its application to a magnet. For he took a rod four feet long, and which was 4015 j grains in weight before it had scented the magnet, but which, after application to it, had decreased in weight by two grains. He next took another magnet, 4584| grains in weight, which, after application to a magnet, had decreased by 2f grains. He then took another, 14,79 2 J grains in weight, which, after application, had decreased in weight 2 J grains. He again

<sup>1</sup> *Ars Navigandi super, et sub Aquis*. Parisiis, 1644, p. 248.—Trs.

<sup>2</sup> *Animadversiones in Decimum Librum Diogenis Laertii*. Lugduni, 1649, vol. i., p. 373, and *Opera Omnia*. Lugduni, 1658, vol. ii., p. 129.—Trs.

took another, 65,726 grains in weight, which in like manner had decreased by 14 grains; and he refers to Hauksbee as a witness of his experiments. Being desirous of repeating similar experiments with the greatest care, I took a most accurately adjusted balance; which, although a large one, was set in motion by the Ttr part of a grain, when loaded with a weight of 2 pounds. In order, however, to prevent the iron, whose weight I was ascertaining, from acting upon the balance, I suspended it at the end of a brass wire 5 feet long; being unwilling to place it in the scale, because the margins of the latter, folded down, contained within them iron wire; this being the way in which the manufacturers at that time made them. I then took some long iron cylinders or rods, of the weight respectively of 2500, 6800, and 14,580 grains. These particulars being most carefully attended to, I then rubbed some of the pieces of iron against an excellent magnet, and examined each of them separately in the middle of a cellar, to avoid the possibility of any action being exercised upon the iron balance, or upon iron that might be in the floor or ceiling, arising from a communication of the magnetic force. In all these cases, however, I confess that I could not discover any difference in the weight. In order to be more certain that the balance was sufficiently sensitive, I placed half a grain successively at each extremity of the beam, which caused it to descend ; so that I could not doubt its sensitiveness. Great of course was my surprise; because these experiments by no means agreed with those of Whiston; which yet were instituted by the most experienced men, to whom I had reason to give credit for much more skill and accuracy in making experiments than to myself. Diffident, therefore, as to my own results, I proceeded on another day to make other trials with other iron rods and blocks of 8050, and 15,565 grains. In so doing, I paid attention to everything which might possibly interfere with the experiment: putting away all the iron I carried about my person ; wiping the axle and the scales of the beam, as also the needle, in

order that the whole apparatus might be as sensitive as possible. However, on examining the weight, I found it remained unaltered as in the former case. These different results, therefore, of the experiments, depend either upon some difference of force with which different magnets act upon the iron, one of which renders the iron lighter and the other leaves the weight the same; or else upon some difference in the care with which the experiments were conducted. If we examine the experiments of Whiston, they seem to present to view something extraordinary. For iron of 4585-J grains, lost 2f grains; another piece which was heavier and of the weight of 14,792 J grains, lost 2 J grains. So that the heavier piece of iron experienced a smaller loss of weight than the lighter; while, in another experiment, the heavier piece of iron weighing 65,726 grains, lost 14 grains, and therefore more again in proportion. Now these results do not appear to agree with one another ; for why should the iron, weighing 14,792J grains, not lose more weight after being rubbed against the magnet, than the iron weighing 4585| grains? Still the observations of Whiston cannot be denied ; for they are a simple record of experiments. In weighing a body we may, however, easily fall into error, in consequence of not sufficiently attending to the minutest details; as I have learnt from experience. For instance, beginning to repeat the experiment of Whiston, I suspended some iron rods from a long hemp cord of the thickness of a goose-quill. What was the result ? I had by chance lit a fire in the room in which I made the experiment; and I remarked that the beam on the side on which the rod was hung gradually became lighter ; particularly after I had waited for some little time. Therefore I concluded that Whiston was right in his observation, that iron, rubbed against the magnet, becomes lighter. I know not, however, by what chance I was induced to remain still longer, so as to note the difference in the weight more accurately ; a circumstance which led me to observe that the beam on the same side became lighter still. The apparatus I

now left to itself till the following day ; when I found that the beam on the same side was not lighter as before, but heavier ; thus it appeared, that this difference in weight depended on the moisture which clung to the cord, which had been expelled by the warmth of the fire; but which, on the day after, when there was no fire, had again insinuated itself into the cord. I therefore in all my subsequent experiments suspended the iron rods by means of brass wire. The scales of the balance had also been always suspended by chains of brass, in consequence of the same inconvenience, which I had observed some time before. But even in this case I never discovered any difference in the weight. In order to omit nothing to complete the experiment, I suspended the rods not only in one manner, but weighed them when suspended also inversely. I moreover applied them to the north pole of the magnet, and also rubbed them against the south pole ; but always with the same result. I made the experiment on different days, when different winds were blowing; also, after the interval of a month; but never witnessed a different result. From our experiments, therefore, I may safely conclude, that the weight of the iron, after being rubbed against a magnet, remains the same as before. Let us now grant the existence of a magnetic fluid according to the hypothesis. These effluvia must have their weight; just as all other bodies that we know, have weight. Let the effluvia issue from the magnet and enter into the iron ; then the weight of the iron will be necessarily increased, while the volume of iron remains the same. Yet in our experiments, no increase or decrease of weight was observed. On what ground then can we affirm that corporeal effluvia are present in the iron ? Perhaps an illustration will be offered from odoriferous bodies, which for a long time give out their effluvia without any sensible loss of weight. In this case, however, a corporeal substance is extracted, which may be retained by metals, taken, and weighed; so that nothing can be proved from the instance of odours. In examining these experiments I bestowed

no little labour ; because if any difference is found in the weight of iron after being rubbed against a magnet, then it manifestly appears that two conclusions must follow : 1. That the magnet is controlled by corporeal effluvia, and that these" - have communication with the iron. 2. That if the iron be rendered lighter, its effluvia must be deprived of their weight, and must also take away part of the weight from bodies; conclusions which involve important consequences to the physical laws of nature, and no little change in philosophy, particularly as expounded by Newton.

“ EXPERIMENT XXVII.

*Fig. 42.*

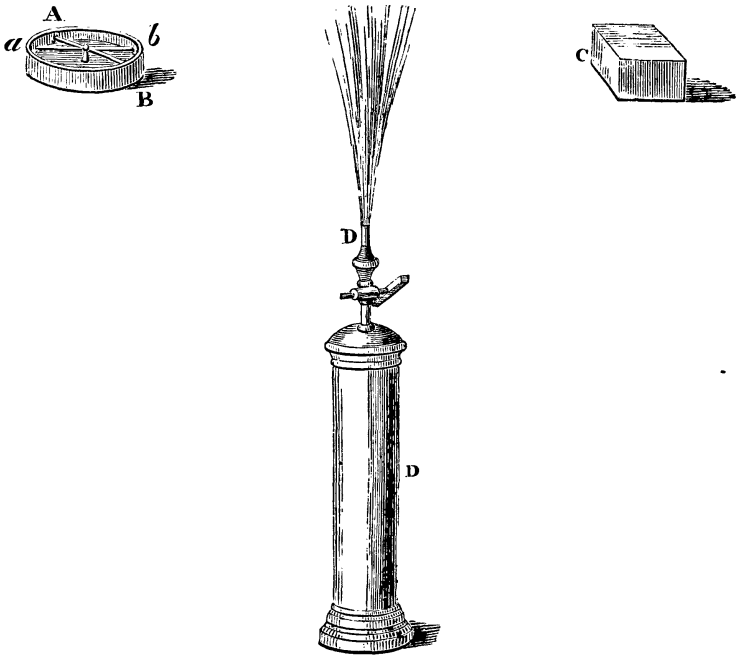

“ Fig. 42. Let a mariner’s needle be placed in its meridian AB, enclosed in a copper case, and covered in on the top with glass, the edges of which are cemented to the case so as to prevent any air from coming in or going out. Let

the magnet C be fixed at a certain distance from the needle, so as to direct its point A to a, that is, to some given degree from the meridian, which should be noted. Then in the copper vessel D let the air be condensed as much as possible by an air-pump. Let the vessel D be placed in such a manner below the continued right line ABC, that the orifice D may be exactly under it. Then let this orifice be suddenly opened, and observe also whether the needle *ab* moves. The air issuing from the brass vessel will produce a very powerful blast, which will continue for some time, and yet the needle will be seen to remain unmoved. Let us now suppose that there are magnetic effluvia, or some other fluid, directed from the magnet toward the needle, I ask whether the motion of this fluid will not in some measure be affected by the power of the blast, and consequently whether in the meantime the directive force of the needle will not act from a towards A; for before the orifice D was opened, this force was in equilibrium with the attractive force of the magnet. But if the wind thus excited cannot act upon the fluid, of what nature can this fluid be? Surely not corporeal for it cannot be that an extremely dense artificial wind, which, by its impetus and velocity may sometimes be made to overcome the natural wind, should not act upon the fluid, nor propel it upward and disturb its motion. Since, however, neither any perturbation nor any motion was observed in the needle *ab*, it follows that by this experiment the hypothesis of magnetic effluvia, or of any other supposed fluid surrounding the magnet, however subtle, cannot be maintained.

“EXPERIMENT XXVIII.

“ Fig. 43. The needle AB was enclosed in a case and standing by itself, and there was placed in the line of its meridian AB, the magnet C, at a distance of 6 inches; by this the needle was deflected into the position *ab*; then



instead of the vessel D, a large saucer full of spirits of wine was used ; from this when lighted there issued a high and broad flame, filling all the space between the needle and the magnet. This flame continued to burn as long as The'' spirit afforded proper nutriment, which was provided in large quantities in order that the observation might be continued for a long time, and that we might with the utmost certainty ascertain whether the needle always pointed in the same direction or not. Now no deviation from the line *ab* occurred during the time of our observation ; and when the flame was put out, the needle remained altogether unmoved. The same result from a similar experiment is recorded by the Florentine philosophers, in *Seggi di Naturali Esperienze fatte nell'Accademia del Cimento*, p. ccxviii.; also by Wolff in his *Vernunfftige Geclancken*, § 382, and Poliniere in his *Experiences de Physiques*, Paris, 1728, p. 298. But since the flame of the burning spirits of wine was exceedingly thin and rare, and not very warm, I thought it desirable to produce a stronger and denser flame, in order by the experiment to avail myself of a still stronger argument. I therefore lighted the large burning lamp O, the flame of which being fed with rapeseed oil was extremely hot; and was moreover condensed by the force of a powerful blast from a large bellows,

Fig. 43.

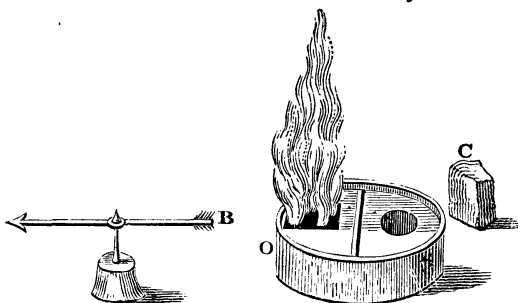

so that it would melt glass and every kind of metal in a very short time. This flame was placed so as to cut at right

angles the straight line from the needle AB to the magnet C. The needle AB was deflected from its meridian by the attraction of the magnet C. Between the lamp 0 and the needle AB a plate of glass was held, in order to prevent the needle from being disturbed by the motion of the wind passing through the flame. As long as the lamp continued burning the direction of the needle was not changed, but remained in a state of perfect rest.

“ But let us again suppose that there exists a magnetic effluvium, or some other fluid, carried from the magnet C to the needle AB; that the needle by it is deflected from its meridian and is in a state of equilibrium with the directive forces of the effluvia; can it be presumed that these imaginary fluids will pass without any decrease of their forces or change of direction through the densest and hottest flame, the parts of which are very solid and move with infinite rapidity ?

“ If, however, there is any decrease in the forces of the fluid passing through the flame, then will the needle in proportion tend to return to its former meridian; being directed by the forces acting upon it from the front. But yet we find that it stood still as long as the experiment lasted.

“ Now, hitherto, no one has found any motive power in the universe stronger than that of fire; since, by its tenuity, intensity, and rapidity, it dissolves all bodies, prostrates them to the ground, or destroys and dissipates them. Shall then the power which sets all other things in motion be incapable of dispersing the magnetic effluvia ? if so, what species of body must they be ? If its particles are of diminutive bulk, if they are mobile and solid, like the parts of all other fluids; then may\*they be struck by other corpuscles impinging upon them; and also retarded, pushed back, or moved in some different direction, like larger bodies. They will, therefore, be propelled by the fire and the flame, the parts of which cannot but meet the effluvia. Therefore the direction of

the needle AB must necessarily be changed; but if it remains unmoved, it follows that the effluvia do not pass from the magnet through the flame; and consequently that the properties of the magnet are not due to any fluid or effluvia.

“ Let any one examine the several arguments which we have brought against the hypothesis of an aerial or ethereal fluid, or of effluvia, which are said to be the cause of the magnetic phenomena; let him compare them with one another, and see what they amount to, and he cannot but be convinced that the magnet is under the influence of some other cause, and that the existence of effluvia is only an hypothesis such as was assumed by Empedocles, Democritus, Leucippus, Epicurus, Lucretius, Descartes, Sturm, and other celebrated men; but which has never been proved. Consequently all the other theories founded upon it are equally groundless.” (*Op. cit.*, pp. 57-71.)

## CHAPTER IX.

### VARIOUS WAYS OF DESTROYING THE POWER OF THE MAGNET; AND CHEMICAL EXPERIMENTS MADE WITH IT.

#### A PRIORI OR FROM FIRST PRINCIPLES.

By means of fire or great heat the magnet is made to lose its forces, and also the rectilinear and regular arrangement of its parts ; and together with these, its magnetism ; consequently it assumes the nature of iron, and is unable to form around itself any regular sphere. After being raised to a white heat nothing remains which enables it to adjoin itself to another magnet, with the exception of its parts of iron. For the fire itself, as we have stated above, sets in motion every particle of the structure of the harder bodies, and by reason of its own inquietude is perpetually assailing and molesting it; resolving one portion into a fluid; ejecting another in the form of little flames or sparks; and pursuing another from place to place. Therefore it converts the rectilinear arrangement of the parts into one that is irregular and but little magnetic. Consequently, after undergoing such a series of changes and internal commotions, the magnet is no longer enabled to maintain its character. It has no longer a mechanical or regular geometrical structure; it is no longer endowed with regular passages leading from one pole to another; consequently, has no longer a regular sphere formed by a wave of effluvia. Therefore, after its extinction as a magnet, as on a funeral pile, nothing but the iron remains of its former virtue; nothing but this which is

capable of conjoining it with another magnet, and which by contact can restore it to its former state. Thus in fig. 20 (p. 266), we see a magnet not yet heated; having within  $j/t$  lines running straight from one pole to the other, or from one side to another ; as from  $b$  to  $c$ , from  $d$  to  $e$ , from  $f$  to  $g$ ; whence the effluvia at  $cegTL$  can combine into a regular sphere. In fig. 19 (p. 265), however, we see a magnet after it has been heated; in which the parts at  $abcdef$ , branching from one another, turn themselves not in one but into every possible direction ; the consequence of this is that neither pole, nor axis, nor sphere can be formed.

2. By sublimations, solutions, and other chemical operations on the magnet, its parts, and structure, nothing further can be discovered than that a magnet consists of parts of different kinds; but that the magnetic virtue and quality reside only in the iron particles. When philosophers, both ancient and modern, could not penetrate into the causes of the magnetic virtue, they endeavoured to take to pieces and examine the magnet minutely and chemically ; supposing that by these means something would be brought to light, in which they might see the magnetic virtue, just as by dissection we are enabled to see the heart and the lungs. Their attempts, however, were always fruitless; particularly as the magnet admits of no opening or section in its veins without destroying the rectilinear direction of its parts, and, together with it, the magnetism, or the force, virtue, and soul, as it were, of the magnet. Some have pounded it into a fine powder or dust, and have repeatedly distilled and digested the dust in some solvent or other by means of a retort or flask. Others have tested it by passing it through a retort with salts and empyreumatic oils; with acrid spirits, both acid and alkaline; and also with sweet ones. Others have digested the filings of the magnet by submitting them to a gentle heat in sand, in a furnace, or on a dung-heap; they have busied themselves with extracting the tincture by means of some essence or solvent mixed up with it. Others

have macerated it in a cold state; have boiled it down and precipitated it. Others have tried to fix it by mercury; others, by placing it in a blast furnace, to reduce it to ashes or to dross ; others have attempted to roast it in furnaces by a slow heat, and to reduce it to an irregular mass. Others have exposed it in the focus of a burning glass to the concentrated rays of the sun ; others have melted it down into a vitreous substance. Nor do they appear to have omitted any chemical torture, to which this poor unoffending stone has not been submitted ; by inflicting upon it thousands of bruises, and submitting it to the ordeal of the crucible in order to force out from it the secret of its latent virtue. But all the labour has been in vain ; for nothing further could they discover than that the magnetic stone consists of things of the most different kind taken from the mineral kingdom ; as for instance, of stones of various kinds, of sulphurs, salts, and metals; and also that the residuum, or only thing upon which the magnet can act, is iron; which, on the approach of the magnet, revives and is restored. Since, therefore, all its force and strength consist in the regularity of its pores, and in the geometrical arrangement of its parts ; and since it owes its virtue to its effluvia and mechanism ; to what purpose is it to inflict this chemical torture and scourging ? What can one hope to gain from it ? Is not the attempt of the same kind as if one wished by solvents, salts, or fire, to extract the image of the spectator out of a looking-glass ? or the various colours it presents out of a prism ? or the various rays of light, out of the organ of vision ? or mechanism, out of the ashes of a machine ? or as if one attempted out of a substance to extract its modes; or out of flint or steel, the sparks of fire; or out of the blood and brain of Archimedes, to discover by dissection and analysis his mechanical genius ? You cannot from a form extract an essential; all that can be done in the case of the magnet is simply to obtain the iron ; which like the particles of all iron will approach and lift itself toward the magnet. But if

we effect a chemical destruction of the iron, then we also destroy every quality that can exhibit magnetic phenomena.

Nor if we plunge the magnet into any acid or corrosive solvent, shall we by these means deprive it of its virtue<sup>^</sup> unless the solvent be so subtle and powerful as to penetrate the entire mass, to dissolve its interior parts, to bend and turn them into a different position, to direct the rectilinearity of the passages, and to incline them in every direction. A solvent of this kind acts like fire ; deprives the magnet of its form, and consequently of all its virtue.

3. By reducing the magnet to dust, the magnetic quality is lost and dispersed. For if the magnet is converted into powder or filings, then in every particle of the powder or filings there remains some portion of the attractive virtue or force, endeavouring to form around itself an extremely small sphere ; but inasmuch as one particle has a different position from another ; inasmuch as one turns at an angle, another applies its pole to the equator of the other, or to a similar or dissimilar pole ; inasmuch as all join their sides to one another at different angles, so that there is no straight transit from one to another, and therefore none through all ; there is no regular surrounding sphere, nor any power of magnetically drawing the iron to it. It is the same in the case of ice or glass ; for, when reduced to a powder or dust, their pellucidity and transparency vanish, although in each individual particle there remain regular interstices for transmitting the rays.

4. However, by the application of some kinds of salts the interior parts of the iron or of the magnet may possibly become so associated with them, that the iron or magnetic effluvia may have no power to go forth, and thus to separate itself, until a melting heat disengages the iron parts from their bonds. For saline corpuscles can either dissolve or unite the parts of smaller and larger compositions and connections in hard bodies; as is well known from chemical experiment. For by these means, as by so many hooks and links, the

subtle and cohering parts of iron may be held fast and chained together ; thus they may be so constrained that they can no longer disengage themselves from their bonds, except by the aid of fire, which unfastens, dissolves, and dissipates them. By means of salts not only may metals be destroyed, but reduced into substances foreign, as it were, and unlike themselves ; as for instance, into vitriols, *croci*, *ochrce*, *'lunce*, and other things from which they cannot separate themselves except by a division of their parts, or by fire. Hence also possibly there are some salts, which, acting as obstacles, block up the pores and deprive all the most subtle parts of the power of going forth and flying off. Knowing nothing however as yet of the mechanism of the interior structure of metals, nor of the figures of salts, nor of their operations in solvents, we are obliged, when referring to them, to reason only in the dark : therefore in treating of the subject, we cannot introduce any principles of mechanism, but must refer only to the evidence of chemical and general experiments. Consequently, deriving our information solely from experiment, we cannot arrive at any certain conclusion beyond the simple fact, that by some kinds of salts the smaller parts of metals may be held fast, and cannot be liberated, except by fire, by solution, or some other chemical expedient. Thus also the parts of the iron being under the coercion of saline particles which hold them fast, and being deprived of all liberty of unfolding their forces, are unable to form any connection with the magnet. Of these subjects, however, we shall treat further in our theory of the mineral kingdom.

musschenbroek's experiments.

“ EXPERIMENT XXIX.

“A magnet, which, when held to the needle or over iron filings, gave indications of very considerable attractive forces, was placed in the fire of a blast furnace fed with charcoal



and coke, so as to keep it red hot for five hours. After cooling, when applied to the iron filings, it would not attract or lift the slightest particle ; all its powers, as was evident from the first, being entirely destroyed ; as indeed is confirmed by Lana Terzi<sup>1</sup> and Boyle,<sup>2</sup> who assert that fire expels from the magnet all power of attracting. Lemery also, by another experiment recorded in *Histoire de l'Académie Royale des Sciences*, 1706, *Memoires*, p. 119, attempts to prove the same phenomenon ; observing that a magnet, exposed to the solar rays in the focus of a burning glass, although not for such a length of time as to melt it, lost all its attractive power. And yet a magnet examined by me, when placed at the distance of half a digit from a mariner's needle 6 inches long and perfectly free to move, gave manifest indications of surviving forces by its moving the needle, attracting and repelling it; and I think that in the magnets examined by those learned men I have just mentioned, there still survived some slight symptoms of magnetic force, which would have shown itself, had the magnets been applied rather to the needle than to iron filings. For I heated the magnet in so strong a fire, that I doubt whether Lana Terzi and Boyle exposed their own to so great a heat; except in the case in which the focus of a mirror was employed. Let no one, however, imagine that a longer duration in the fire would have produced greater effects upon the magnet, or have destroyed all its forces ; for from the chemical analysis of the loadstone it will be evident in the sequel, that the magnetic forces are never entirely destroyed by fire, even though the experiment is frequently repeated. Since, however, in a preceding experiment, we have intimated that fire does not act upon the forces of the magnet, while in the present case it is evident that the fire considerably diminishes its force ; we cannot but wonder that upon one and the same kind of body

<sup>1</sup> See his *Magisterium Naturæ et Artis*. Parmse, 1692, vol. iii., lib. xxiii., cap. 1, p. 214.—Trs.

<sup>2</sup> See his *Philosophical Works Abridged*, by P. Shaw, vol. i., p. 503.—Trs.

fire should produce such different results. I suspect, however, on examining the result of the experiment, that the fire had expelled from the magnet certain particles, such as iron and others, upon which the whole attractive force depended ; hence that what was left was no longer attracted by the magnet. I, however, pounded a magnet into a fine powder, and at the distance of two or three inches held to it another powerful magnet, which attracted the whole of the dust, lifting and carrying it just the same as if they had been iron filings. The fire, therefore, had not as yet expelled from the magnet those particles in which the attractive force resided ; for then x the powder would have remained undisturbed, and not have flown to the magnet ; whereas it gave indications of an attractive force still surviving within itself; since where there is no reaction there can be no action ; for all bodies necessarily attract one another with equal and reciprocal force.

“In this stone the fire had changed the figure of the pores ; for the stone had become lighter and redder ; but it could not, therefore, be said to have lost its power; for what is a pore but a part of a space which by nature is inert, and which, whether circumscribed by limits in this way or the other, cannot acquire any forces ? consequently a merely changed figure of the pores cannot be maintained as a cause of the loss of the forces. For the fire acted upon something that was in the magnet; no doubt, therefore, it acted upon something corporeal. It likewise operated in such a way, that, whereas the stone before possessed considerable powers of attraction, the fire had now in some measure expelled or rather silenced them ; silenced, we say, rather, because in the magnetic dust the magnetism was again observed when excited by the other magnet, which resuscitated in it the same forces with which it had been formerly endowed. A very powerful fire, therefore, only subdues the magnetic forces ; because when a gentle heat only is employed the magnet does not lose them. Artizans often join together various pieces of magnets by running round melted lead, tin or other compound metal ;

but we find in the present case, that the magnetic forces are not destroyed by the heat, but remain entire and constant. These forces, therefore, obstinately inhere in the magnet, and are not to be expelled except by the strongest power of a long continued fire ; and even in this case perhaps they are not so much expelled as subdued. Still there is much obscurity as to what that is in the loadstone in which the magnetic forces reside, and what is the manner in which it is disturbed or affected by the fire, so that it is no longer active but inert. Here intellectual sagacity has availed nothing hitherto ; for indeed were this point arrived at, then would all the magnetic effects and operations be also well understood. If the unknown cause were corporeal, and issued out of the magnet, then when the magnet operates there would be effluvia, from the going out and return of which would arise all the phenomena. But we have above intimated by what numerous difficulties the doctrine of effluvia is beset; so that this is a position which we cannot maintain. If, again, it were something corporeal which does not issue out of the magnet, how can it agitate, move, and draw to itself, bodies which are placed at several feet distance ? The mind does not in the least understand this. Yet is it not an established law of nature—a law impressed by the Creator upon all bodies, that when they are placed near each other, or at some given distance, they attract each other, and mutually approach and cohere; although there is no outside agent to push them, and nothing in the intermediate space to attract them ; and if this law be granted, will not one magnet approach toward another or toward iron ; and will not all its operations follow from this cause? Yet although I grant that such a law is established by the Omnipotent Being, still it does not follow that, in virtue of this law, the phenomena which are presented by the magnet can be explained; because after being submitted to the fire, or before it is dug from the mine, if in each case the mass was of the same volume, the attractive forces would also remain the same. Now the fire

cannot act against the laws of nature, neither can it change or destroy them; and yet it succeeds in expelling the principal part of the magnetic forces. Moreover, there are many objections to this opinion ; for it is a matter of regular observation, that if a magnet is forcibly struck with a hammer, so that all the parts vibrate ; if it is reduced to a powder, covered with rust, exposed for a long time to a damp air; made to lie in its meridian in a position opposite to its natural one: placed near another endowed with stronger forces ; it is deprived of its virtue, is injured, and enfeebled ; as is attested not only by my own observations, but also by Descartes in his *Principia Philosophic<sup>a</sup>* : Amstelodami, 1650, par. iv., § cxlv., nos. 33, 34, p. 265 ; by Schott, *Magia Universalis*, vol. iv., p. 286; by Wolff in his *Vernunfftige Gedancken*, § 382; by Lemery in *Histoire de VAcadlmie Poyale des Sciences*, 1706, Memoires, p. 119 ; by Boyle in his *Philosophical Works Abridged*, by P. Shaw, vol. i., p. 499 ; and by several other learned men. In all these cases, the substance and size of the stone remained the same; and therefore, in virtue of an innate law of nature did not exercise any less degree of attraction. Nor would the changes of season and of the weather give rise to the slightest difference in the forces; a difference, however, which has been said to exist by the learned Derham in the *Philosophical Transactions*, vol. xxiv., pp. 2136-2144. For that excellent magnet which is in possession of the Royal Society of London, sometimes so suspends iron as to cause it to adhere at a distance of 8, 9, or 10 feet; although at other times it does not sustain it at a distance of 3 or 4 feet. Now no one would say that a change of season could induce a change in a law of nature ; consequently it is obvious that this change cannot be the cause of the magnetic phenomena. The magnetic force of the loadstone must depend upon some other cause ; and the attractive power exhibited by this stone ought to be carefully distinguished from the several other attractive powers which are observable in bodies, and

which are equally endowed with other properties, and are subject to a different law.

“ On a consideration of the difficulties attending the various speculations concerning the causes of the magnetic forces, propounded by different learned men, it might possibly be expected that I should myself assign some other cause, by a reference to which the various phenomena of the magnet could be resolved and demonstrated, and which by solid arguments I should prove to be the only true one. Nor indeed has my attention to this subject been slight, comparing as I have many experiments with one another, inventing various hypotheses, trying different experiments in new ways; but the more I laboured, the farther I found myself from the prospect of arriving at the true cause. Therefore, tired of my labours and conscious of my incapacity, I am compelled candidly to confess, that the cause of the magnetic phenomena still remains a secret, unknown to any mortal being. Indeed the learned Whiston, who was so skilled in the science of the magnet, acknowledges that he himself had taken great pains to discover the cause of the magnetic forces ; yet that he could not find any hypotheses to satisfy him; any of which were able to resolve the phenomena into their mechanical principles; and, therefore, that he was unwilling to obtrude any upon the learned world.<sup>1</sup> The learned Hamberger, in his *Elementa Physices*, cap. viii., is of opinion that the cause of the magnetic phenomena is a certain fluid surrounding the magnet; but he adds :—<sup>1</sup> What the nature of this fluid is ; what the nature of its motion ; what the disposition of the pores ; and how from these causes the phenomena result, we can explain only hypothetically; nor even in this case will any hypothesis altogether suffice’ (p. 184). Now this does not differ from a confession of complete ignorance of the cause of the magnetic phenomena ; an ignorance which he afterwards acknowledges in his *Programma Inaugurate de Partialitate Acus*

<sup>1</sup> *Longitude and Latitude Found*, p. 88.—Trs.

*Magneticoe* <sup>1</sup> where he says, § xvii., “that the genuine cause of the hostility and amity of the magnetic poles, or of the magnetism of the needle, he believes to be unknown.” Besides, much to our present purpose is the remark of Aphrodisseus, who, after having given the greatest attention to the magnet, exclaimed that its attractive force was known to God only. If now we consult Galen and Avicenna, we shall find in like manner that these authors did not understand the force of the magnet and pronounced it to be divine. If we adduce the testimonies of other learned men who have paid the most careful attention to magnetic phenomena, we shall find them confessing that the cause of the phenomena is still a secret; we shall find Camerarius also in the judicious remarks in his *Pissertationes Taurinenses Epistolicoe Physico-medice*, p. 265, frankly acknowledging that the reasons for the magnetic phenomena are still undiscovered, and particularly for those which concern the declination of the magnet,—a remark to which Wolff gives his assent in his *Vernunfftige Gedancken*. From our experiments and arguments, it is evident, that the cause of the magnetic phenomena is not to be found in any magnetic effluvia, or in any vortices of an imaginary surrounding ether; for, to use the words of Whiston, ‘ I cannot devise any such motion of subtle fluid belonging to the loadstone as shall account for an attractive power in the sesquiduplicate proportion of the distances reciprocally.’<sup>2</sup> And even could we conceive the existence of the motion of such a fluid, this would not suffice to enable us to maintain that a fluid of this kind was the true cause of the magnetic phenomena ; as in a parallel instance Cotes has observed in his preface to the work of Newton.<sup>3</sup> Or does it consist in some *Motive* or *Local Blas*\* as Helmont sup-

<sup>1</sup> Prefixed to *Elementa Physices*.—Trs.

<sup>2</sup> *Longitude and Latitude Found*, p. 89.—Trs.

<sup>3</sup> *Philosophise Naturalis Principia Mathematica*. Can tabrigae, 1713, 2nded.—Trs.

<sup>4</sup> The term *Blas* was coined by Van Helmont, by which he means, as he says, the force producing motion ; of this he makes two kinds ; the *Blas Meteoron* •and the *Blas Humanum*. The first belongs to the stars and is the pulsive

poses ?<sup>1</sup> What, however, is this but mere words unintelligible to any one ? Must there be then some universal soul or spirit which is the motive power of the magnet ; such as Hermes, Zoroaster, Orpheus, and other more recent philosophers believed ? If so, the cause of the magnetic phenomena cannot be mechanical. Before, however, we admit the existence of this spirit, and its power of attracting or of pressing against bodies, this very existence has to be proved ; and this no one has ever yet been able to do; unless by this spirit we understand that God who is the most wise Author of all things in the universe ; who is the first moving power of all things ; by whose power and energy are produced the magnetic effects which flow immediately from Him, without any, or without many, intervening causes. But this immediate operation of God upon the magnet we cannot prove ; although nothing can be more certain than that in following up the train of causes we must ultimately arrive at God, and in Him we must end as the first cause of all things. Between God, however, as a cause, and the magnetic forces, there must intervene some other cause; for the same magnet either acquires or loses its forces according to the different position in which it is placed. It loses, in some measure, its forces in the fire. Iron also acquires magnetic forces by hammering, the more it is hammered, the greater are the forces acquired ; a fact which excites in me a suspicion that there must be some other intervening cause. The various other discordant hypotheses of different philosophers I shall pass over. They may be found in Gilbert, *De Magnete*, lib. i., cap. i., and in Cabeus, *Philosophia Magnetica*, lib. ii., cap. ii., p. 100.

“ If any one will seriously consider these things he will readily perceive how far we are from a knowledge of the nature of bodies; although some persons boast of their possessing it as if it were to be found in some one or other force by which they perform their courses ; this is their *Local Blas* ; the *Blas Humamm* he supposed to operate in men and brutes. (See *James's Medicinal Dictionary*. London, 1743-5.)—*Trs.*

<sup>1</sup> *Opera Omnia*, p. 455.—*Trs.*

universal attribute. But let these persons try whether from the nature of bodies known, as they think to themselves, they can find out the nature of the magnet and its forces; and this without obtruding upon us hypotheses as they are accustomed to do, but by offering to us fair demonstrations.

“The only way remaining to us, as philosophers, of discovering the cause of the magnetic phenomena, is by rejecting the lust of hypothesis, as I have often said, and which cannot be too often repeated; and by dedicating our labours to the performance of experiments and to observations upon the magnetic phenomena; thus by seriously setting to work, and not by wasting our time in sitting still and doing nothing but indulging in reveries ; for as Reaumur has wisely observed, ‘natural philosophy has been studied too much in this manner and to its prejudice.’ In this case we might possibly, in course of time, perceive some ray of hope ; and some gifted person might arise, who, by comparing the numerous magnetic operations with one another, might bring to light their cause ; in which case how would posterity wonder that we were ignorant of such obvious truths, although in the present age we bordered so closely upon them •

#### “ EXPERIMENT XXX.

“ Seeing that by the aid of chemical analysis we not unfrequently detect the different parts which compose the larger bodies, I resolved to examine the magnet by this method ; suspecting as I did that this body was not simple, but compounded of several others of a different nature; and if I could separate these, I hoped to arrive at those inert parts which are endowed with no attractive force, and also at those other parts in which all the force resides ; so that from these, as examined by the microscope or in some other way, we might discover the construction of the magnet and the cause of its virtue. I therefore directed my whole attention



to a dissolution of the magnet into its more simple parts ; supposing as I did that it was a body compounded of other bodies. Boyle had in some measure preceded me in his attempts, but had made such little progress, and was comparatively so little careful in his manipulations, that I could derive from them little or no light. I have thought it desirable, however, to present them to the reader in conjunction with my own; particularly as they may be described in a very few words. This philosopher heated different magnets in the fire, and then observed a great diversity in their substance; some, as they cooled, dissolved into dust; some became friable; others remained entire ; others appeared to have interior cracks, and looked like scales of iron ; others resembled plates of variegated colours and parallel to one another; others appeared to be little changed either in colour or solidity. None of these magnets, when in the fire, emitted a blue flame indicative of the presence of any sulphur; although Porta<sup>1</sup> affirms this to be the fact, supposing that the magnetic force resides in the sulphur. From these extremely diverse forms of magnet submitted to the fire, it is evident that the substances which compose them are various; some of which are more volatile than others.<sup>2</sup> We now, however, hasten to the analysis of the magnet, which we shall conduct in different ways; so that what is not discovered by one method may be disclosed by another.

“FIRST PROCESS.

“ Because the entire magnet, when heated for some time in a fire, so far loses its power of attracting iron that it ceases to attract filings, although it acts upon a magnetic needle six inches long, I endeavoured to ascertain whether it

<sup>1</sup> *Magia Naturalis*. Lugduni Batavorum, 1651, p. 286.—*Trs.*

<sup>2</sup> See *The Philosophical Works of R. Boyle Abridged*, by P. Shaw, vol. i. p. 501, *etc.*—*Trs.*

was possible to expel the whole of the attractive force. This it appeared would be the more easily effected, if the magnet was first reduced to an extremely fine powder, and then submitted to the fire. I therefore chose a magnet of great power and of a blackish colour; and I pounded it in a mortar into an extremely fine powder. I suspected that in this dust there would be some parts which would be attracted by the magnet, and others which would show no sign of virtue. Therefore by the aid of an excellent magnet I endeavoured to separate one powder from the other; but the whole was so homogeneous that every part was attracted. I then measured the distance from the magnet at which it showed this attraction, in order that I might afterwards know whether the power produced by artificial processes possessed a greater or a less attraction than this. I now placed the powder in a crucible which was open at the top; this crucible I placed in a blast furnace, and heated it in a strong fire made of charcoal piled up round it. This I continued for three hours, during the whole of which time the crucible was white hot. On examining the crucible when cool, the same powder appeared and of the same colour as before heating. The powder which was in the crucible, before being submitted to the fire, I had brought near a needle six inches long, to which I gradually moved it in order the more readily to ascertain at what distance it influenced the needle. This distance I had noted, and now again on exposing the crucible with its powder to the needle, the former attracted the latter at the same distance as before. I next held a magnet over the powder which had been shaken out of the crucible ; but the powder was not immediately attracted at the same distance as before; though after waiting a minute or two, I found it attracted as strongly as before the heating.

“ I did not attend to the weight of the magnet before and after heating, because I could not prevent the charcoal from falling into the crucible and so altering the weight.

‘ From the result of this experiment we learn that the

attracting force of the magnet cannot easily be expelled by fire, although it may be considerably diminished throughout the entire mass of the magnet. Therefore it seems, that after the magnetic force has decreased to a certain point, heating for a few hours longer will not cause it to decrease further; a fact which shows that the principle of attraction in the magnet is not very volatile.

#### “SECOND PROCESS.

“ I next tried whether the principle of magnetic attraction could not be vapourized, by mixing saline substances with the magnetic dust ; such, for instance, as in general exercise the greatest power of penetrating bodies, and of carrying away and evaporating all that can be rendered light and subtle. To this end I took three drams of the same magnet reduced to powder, and an equal quantity of corrosive sublimate of mercury. These two, pounded together and well mixed, I poured into a glass vessel, and exposed it for three hours to a hot bath of sand. All the mercury was now sublimated, and adhered to the top of the arch and to the neck of the vessel, as in all other cases of its sublimation ; yet it had not carried up with it any portion of the magnet, which still remained in the form of dust at the bottom of the vessel. When the vessel was broken and the dust extracted, the attractive force was observed to be the same as before the operation.

“ Inasmuch as in chemistry we sometimes find that we cannot effect by one operation what may be effected by repetitions, I collected together the former sublimated mercury, and mixed with it 11 scruples of metallic mercury, as also the same dust of the same magnet. These three I put into a glass vessel, and again exposed it to the heat of a sand-bath for three hours; after which I found the whole of the mercury sublimated to the top of the arch of the vessel;

and yet it had not carried up with it any portion of the magnet, which still remained at the bottom of the vessel in the form of dust, of the same colour as before, and which, when examined by holding over it another magnet, was found to have lost none of its magnetic virtue.

“ All the mercury which I could collect from this operation I again carefully mixed with the same powder of magnet, and put into a clay crucible, which remained open at the top in order to let me see what effect would be produced by submitting it to a more powerful and an open fire. For it is seldom that we do not obtain different products from the different modes of applying heat. I therefore exposed the mass for one hour to the fire of a blast furnace; when I found that the mercury had escaped, leaving in the crucible the same powder of magnet, changed neither in colour, in quantity, nor in the attractive force which it manifestly exercised upon the needle and the magnet. So that from these trials it is obvious that mercury does not act upon the magnet, or change, corrupt, volatilize, or separate, any portion of it, but leaves the substance altogether intact.

#### “THIRD PROCESS.

“ Although the sublimate of mercury did not volatilize any portion of the magnet, I could not, therefore, conclude that no kind of salt could do so ; because salts are of very different natures, and frequently one will act upon certain bodies while others are inert; as will be evident, not from the present, but from some of the ensuing processes. I therefore took a fresh portion of magnetic dust, but belonging to the same magnet which I had employed in the preceding and all the subsequent operations. To this I added three drams of arsenic ; these powders I mixed well for some time ; enclosed them in a glass vessel, and exposed them to the heat of a sand-bath. In two hours all the arsenic was sublimated, and a great portion

lodged upon the neck of the vessel, leaving at the bottom the powder of the magnet unchanged either in quantity, colour, or attractive force as exercised either upon the needle or another magnet. From this process, therefore, we learn nothing, except that arsenic does not act upon the magnet.

#### “FOURTH PROCESS.

“ 1. Inasmuch as ammoniacal salt volatilizes iron and is sublimated with it, I thought that it might partly or wholly volatilize the magnet. Nor was my expectation disappointed, For I took three drams each of ammoniacal salts and of the powder of the magnet. Both these were pounded together and put, when mixed, into a glass vessel, which I placed in a sand-bath for three hours. The heat was not very great, because the vessel containing the sand was not let very far down into the furnace. On the vessel being taken out and broken, there was observed at its bottom a coherent mass, soft, readily friable into dust, and having but little smell. When broken along the middle from the bottom to the top, it exhibited certain strata arranged in the following manner. The lowest stratum was the thinnest of all, and of a darkish hue; the second was of a deep yellow; the third was of a pale yellow ; the fourth was greyish, consisting of a mixture of the dark parts of the magnet and of the white parts of the ammonia ; the fifth or uppermost stratum consisted of the whitest pure flowers of ammoniacal salt, which were light and scarcely coherent.

“ This mass, when brought near a needle 6 inches long, produced in it visible movements, both attractive and repulsive.

“ From the differences in the colours of the strata, and from their different densities, it was evident that a magnet is not a homogeneous and simple body, but a compound of several parts diverse from one another.

“ These various strata I meant to examine separately ; but having my attention called away by other circumstances, I deferred the task till the following day ; when I found that the mass had become softened by the moisture of the air, so that the strata could not with any degree of nicety be separated from one another. I therefore now mixed up the entire mass together.

“ 2. Upon three drams of this mass put into a vessel, I poured some water from a well, to the depth of one digit. This I digested on a little fire of wood for eight days; by which time was extracted a tincture, clear, moderately thick, from a deep to a bright yellow, like the rust of iron dissolved in water. At the bottom of the vessel there remained a considerable portion of the magnet undissolved.

“ 3. The tincture I gently poured out in order to prevent any admixture of the powder. This I evaporated and dried in a vessel of clean porcelain ; a process which gave rise to a dust of an orange colour, having a salt and stringent taste, as though there was present some vitriol of steel. This dust or powder was not attracted by the magnet, although the foot of the armature was brought close to it.

“ 4. This orange-coloured dust was put into a crucible, which I placed upon an open furnace. At first it deliquesced into a fluid, which boiled like water, all the time copiously emitting fumes. After this the dust remained of a blackish hue, or of the same colour as the magnet before undergoing the process ; and was strongly attracted by another magnet; as strongly indeed as if the powder of the magnet had not been submitted to the action of fire.

“ 5. Another portion of the mass described in sect. 1,1 took to the amount of three drams ; and having put it into a deep vessel, I poured upon it spirits of wine distilled by itself, with which it remained digested for eight days ; there was produced a tincture, thicker and somewhat greenish, a great portion of the magnetic dust remaining at the bottom undissolved. This tincture had a sharp and slightly saltish taste.

“6. From this tincture I took all the spirit<sup>^</sup> of wine: leaving at the bottom of the vessel a large quantity of dust of a dusky yellow colour, and having a salt taste, but most acrid and biting ; affording no indications of attraction when either—the needle or a magnet was held to it.

“ 7. This dust I put into a crucible placed upon an open fire; when it exhibited the same phenomena as the dust described in sect. 4; and was reduced to the same blackish magnetic powder.

“ 8. There remained, therefore, in the vessels, the powder of the magnet not dissolved either in water or in spirits of wine; This I put into a crucible ; and on gently drying it, the powder assumed a black colour, and was attracted by the magnet. I then put it into the same crucible as before, and exposed it to a very strong fire for one hour; and there resulted a powder of a deep yellow to a bright red colour, which was strongly attracted by the magnet, and at a greater distance than the magnetic powder before undergoing any process.

“ 9. As the fire, however, was not sufficiently powerful, I repeated the experiment by sublimating a fresh quantity of the powder of the magnet with an equal quantity of ammoniacal salt, and exposing it in a vessel to a very powerful fire. In the course of this operation I volatilized the whole of the ammoniacal salt, which took up with itself to the arch of the vessel a yellow powder from the magnet; the same which in a former operation, with the aid of spirits of wine and water, I had collected in the form of a tincture. In the bottom of the phial there remained a mass of a red to a dusky colour; and which in the open air, within a day, was dissolved by deliquescence.

“ 10. After this I again took three drams of a fresh quantity of powdered magnet and ammoniacal salt; and having thoroughly mixed them in a crucible, I exposed it to an open fire in a blast furnace for an hour; then the whole of the ammoniacal salt had evaporated, carrying with it a consider-

able portion of the magnetic powder, but leaving at the bottom of the crucible a powder of a rosy colour; which was indeed attracted by the magnet, but only slightly, and at a short distance from it.

“ 11. Now, if we attend to everything that occurs in the foregoing process, it is clear that in the magnet there are certain parts which can be volatilized sooner than others ; for those which constituted the yellow colour (sect. 1, 2, 4, 5, 7, 9) ascended in conjunction with the ammoniacal salt; but those which were of a colour approaching more nearly to the black, appeared to be more fixed or heavy, since they remained at the bottom of the vessel. But by this operation we do not penetrate into the art of separating the inert parts of the magnet from those which are endowed with the highest virtue; because those which were volatilized equally retained the attractive force as those which remained perfectly fixed ; since the volatile parts had only to be separated from the adhering salt in order to exhibit again the same magnetic force which they did before ; as may be seen in sect. 4, 7.

“ 12. Still it is surprising that the tincture of the magnet, whether made with water or alcohol, when dried so as to return to powder, (sect. 3, 6) manifested no symptom of attraction, although it contained within itself the magnetic substance, which, after experiencing a still further action of the fire, gave palpable proof of its attractive virtues. The dried tincture, however, contains within itself a considerable portion of salt; the salt strongly attracts the magnet, and causes the attractive force to terminate in itself so as not to be able to act upon another magnet. Moreover, from all our experiments I have constantly learned that nothing but the salt prevents the force of the magnet from being diffused to a considerable distance ; and that all salt restrains its power ; not only the ammoniacal, but also sea salt, *sal gemma*, and nitre ; as will be evident in the sequel. Something wonderful, therefore, takes place between salts and the magnet; the



former hindering that which neither metals, gems, stones, glass, wood, or earths, succeed in doing.

“FIFTH PROCESS.

“ 1. Not having attained my object in the preceding operation, I turned my attention to an experiment with another salt. I feared, however, that I should not derive much aid from this quarter; since experience constantly teaches that no salt opens bodies better than the ammoniacal; but since in physics we cannot form many conclusions *a priori*, I preferred assuming the character rather of an ignorant operator than of a subtle reasoner, who is capable of scarcely anything but hypothetical argument. I pounded into a fine powder three drams each of the magnet and sea salt, which were carefully mixed together. These I put into a crucible, and submitted to a powerful fire in a blast furnace for three hours. The powders formed themselves into a solid mass strongly adhering to the sides of the crucible, and could only be separated from them by breaking it. The mass had turned to a colour verging from red to black, like the *caput mortuum* of vitriol; and everywhere distributed throughout its substance there were little points extremely bright resembling those of broken iron. This, when reduced to a powder, was strongly attracted by a magnet which was held over it. Consequently sea salt does not remove from the magnet any parts in which its force resides; nor does it expel from it the parts which are inert.

“2. Not content, however, with this single operation, I took the former powder which had already once undergone the action of the fire, and after mixing it with an equal quantity of sea-salt, exposed it, in an open crucible, to a very powerful fire in a reverberating furnace, for two hours and a half. By this operation a firm mass was produced closely adhering to the crucible, spongy, with its upper part of an ashy colour, and the lower reddish. The two parts thus differently

coloured I carefully separated from each other ; hoping that by this method I might separate the inert from the attractive portion of the magnet. Each mass, when reduced to powder, was attracted by the magnet; the ash-coloured very strongly, the red-coloured very feebly.

“ 3. From the result of this experiment I concluded that the magnet is a body compounded of a dark inert earth, and of some other matter in which the magnetic power principally resides ; but that this matter adheres most tenaciously to its earth, and consequently in the present operation was not perfectly separated ; for if it were, no magnetic force would be discoverable in the earth, while the attraction in the ash-coloured powder would be greater.

“ 4. I therefore endeavoured by a further process to separate this ash-coloured powder from its earth still more completely ; and for this purpose I mixed with it an equal quantity of sea salt; and exposed it in a crucible for three hours to a most powerful fire made of coal and charcoal. On cooling, the powder was observed to be of the same colour as before ; it was attracted by the magnet in the same way ; nor did I by this method obtain any further separation of the earthy from the other parts ; therefore either the part possessing the greatest magnetic force had escaped, or else in the present operation the fire effected no change. I consequently considered it useless to pursue this method any further; the powder being unchanged by the action of the strongest fire.

“5. I therefore proceeded to try whether I could so far lay open the composition of the magnet as to extract a tincture from it; to this end I poured water upon the dust and digested it for eight days ; but the salt alone dissolved in the water, and no tincture was produced. On perceiving this, I poured on the powder a quantity of fresh water, then a quantity of salt water, in which I soaked it; and then again a quantity of fresh water, till the latter became perfectly tasteless; after which the powder, on being dried, exhibited the same colour as it did before any experiment had been

made with it, and was again also as strongly attracted by the magnet as at first. When the magnet was first held over it, its virtue for a while was not manifested; but after a minute or two attraction took place. The powder, once attracted and afterwards wiped off, was much more easily attracted the second time, and was visibly moved and lifted up; nay, even rushed to the magnet from a much greater distance. The only difference occasioned by the violent action of the fire was this; that at first the powder was not attracted so promptly as that which had not been submitted to the fire.

#### “SIXTH PROCESS.

“ 1. Having already tested the magnet with neutral salt, such as the ammoniacal; and with muriatic salt, such as the marine; I next designed to expose it to the action of fixed alkaline salt. I consequently took three drams of magnetic powder and the same quantity of salt of tartar; and these powders, which had been well pounded and mixed together, I put into a crucible which was placed, open at the top, upon the charcoal fire of a blast furnace; where it remained for three hours. After cooling I found a powder of the same colour as it was before it was submitted to the fire, appearing in no respect changed; setting in motion a mariner's needle 6 inches long, at the same distance as before; and manifestly attracted by another magnet.

“ 2. Inasmuch as salt of tartar does not incline to a dry state, but is strongly attractive of atmospheric damp, I now tried to make it deliquescent; and in this state to see what effect it would have in laying open the composition of the magnet; but now, contrary to its nature, the salt remained dry—a circumstance which seems to result from the great force with which it was endowed in its attraction of the magnet.

“ 3. I consequently put the dust into a vessel, and poured

water upon it to the depth of one digit; in order to see whether, after a long digestion for sixteen days, there would result any tincture. Notwithstanding this, the water remained clear and white, holding in solution nothing but the alkaline salt which had adhered to the powder. On observing this, I purified the powder by thoroughly washing it in pure water ; and then dried it. In this state it gave manifest indications of the power of attracting iron ; a power scarcely inferior to the one which I had observed in the dust before trying any experiment. The powder was nevertheless not pure magnetic powder ; because it retained the ashes, mixed up with itself, which had been left from the salt of tartar; and when separated from this by the aid of another magnet, which acted upon the magnetic dust but not upon the ashy portion, I obtained a magnetic powder which had experienced no alteration. This process I pursued no further ; because I had learned nothing from it, except that the most acrid alkaline salt does not act upon the magnet; and as I had no hope of further discovery by this method, I betook myself to experiments made with another salt.

#### “ SEVENTH PROCESS.

“ 1. I next took three drams of powder of the magnet and the same quantity of nitre, which, after being well mixed and put into a crucible, I exposed to the fire of a blast furnace for three hours until they had become a firm mass, spongy, not shining, inclining to black, so strongly adhering to the crucible as to be inseparable without breaking it. This, when again reduced to powder, was attracted by the magnet, and had retained somewhat of a salt taste derived from the alkali into which the nitre had been turned in the fire ; and since in this, our first operation, the mass was of a homogeneous colour, and presented no separate and distinct divisions, I submitted it to another operation.

“ 2. With the former powder I mixed an equal quantity of nitre, and for 2 J hours exposed it in a crucible to a most powerful charcoal fire in a reverberating furnace. The powder turned into a very friable mass, which could be again reduced to powder by the fingers alone ; it was also reddish but everywhere homogeneous, giving no indication of distinct divisions. On reducing the mass to a powder, I found it was but little attracted by the magnet; I should, therefore, have concluded that the part endowed with the magnetic forces had escaped with the nitre, had I not been perfectly sure that this result proceeded from the quantity of salt everywhere adhering to the powder, and preventing the magnetic force within from acting upon other bodies.

“ 3. Having next placed the powder in a vessel and digested it with water, I simmered it for the space of eight days, with a view to ascertain whether it would afford a tincture, but I found it would not. I then soaked and washed the powder in a large quantity of water, until it was without taste ; this, when dried, remained of a reddish colour, and was attracted by the magnet much more strongly than in sect. 2. Indeed I was in doubt whether there was any difference between the present degree of attraction and that which had been manifested by the powder previous to submitting it to any operation.

<sup>11</sup> From the operation of this salt I was not in hope of making any further discovery. I could perceive, indeed, that its corrosive quality was different from that of salt of tartar or sea-salt, because the powder acquired another colour; for now it was reddish, whereas before it was greyish, reddish, and blackish. Not attaining my object, I prepared for a different method of examination.

#### “ EIGHTH PROCESS.

“ 1. I now took three drams of pulverized magnet and the same quantity of *sal gemma*, both of which were well pounded

and mixed together. I then put the whole into a crucible, which was exposed to the fire of a blast furnace for three hours. This, after cooling, presented a firm mass strongly adhering to the crucible, everywhere interspersed with glittering points visible through a microscope, but which were only the most transparent parts of the *sal gemmce*. On the surface of the mass there appeared an iron colour, which led me to suspect that in the mass there was a considerable portion of iron. In its lower part the mass presented a rough aspect and was much blacker. Not being able to separate the upper part from the lower as well as I wished, I hoped the more easily to accomplish my purpose by submitting the mass to another operation. I therefore first reduced it to a powder, which retained a salt and acrid taste, and was strongly attracted by the magnet.

“ 2. To this powder I again added an equal quantity of *sal gemmce*, and having put it into a crucible submitted it as before to a strong fire in a blast furnace for two hours and a half. The mass on cooling was firm. Its upper stratum resembled the colour of iron ; its lower part was spongy, red, and softer. Both these strata, when separated from each other, I reduced to powder. The powder of the upper stratum was attracted by the magnet much more strongly than that of the lower. Nay further; in the lower stratum there were various parts which were not attracted by the magneto; while on the contrary all in the upper stratum were attracted.

“ 3. There was much, therefore, in the lower stratum similar to that which was found in the upper. Therefore I extracted from the lower stratum all that was attracted by the magnet, and added it to the powder of the upper. With this I again mixed an equal quantity of *sal gemmce*, which I put into a crucible, and submitted to a very powerful fire made of coal and charcoal, which was continued for four hours. After cooling, the mass appeared as a dark substance not very cohesive, but very friable and also homogeneous. To the sides of the crucible adhered particles of a certain

metal the nature of which was unknown to me, of a silvery colour, shining, and in no degree attracted by the magnet. In the course of this operation the mass had considerably diminished, so that a large portion of the salt and of the magnet had escaped ; the whole of the salt, however, had not disappeared, because there was manifestly in the mass a salt taste. In all the parts, when minutely pounded, only a small portion of the magnetic force was observed ; as indeed I anticipated would be the case; because the salt had penetrated everywhere into the magnetic parts, with which it strongly cohered ; inasmuch as the force of an extremely powerful fire continued for so long a time could not separate them. What, however, fire could not do, water easily effected.

“ 4. I therefore poured water on the powder in the vessel, to the depth of about one digit; in which it was digested for eight days : this I did to see whether it would produce a tincture : it however afforded none ; the only result was that the rest of the *sal gern/frice* was dissolved in water. On finding this, I washed the powder in a large quantity of water until it was without taste. When the powder was dried, it was of a darker colour than the magnetic powder before undergoing any operation ; and was attracted by the magnet more strongly than before. This proved that the mixture of salt had impeded its magnetic action, and that some of the inert earth had been separated from the substance of the magnet; for it was unquestionably the same as that which in sect. 3 I had set aside. I, however, did not doubt that this residue still contained much inert matter; which by means of further and long continued operations might be separated from the active; but I had not leisure to follow the experiment. I hastened rather to other methods, hoping that by these I should more easily accomplish my wishes. From all these attempts, however, it is clear that the entire magnetic force cannot be so easily expelled from the magnet as philosophers have thought, in consequence of seeing a large and perfect magnet receive injury in the fire and lose its

forces. The stone, however, does not lose all its forces ; for treat it as we may, it retains some portion of its virtue ; as is evident from the experiments we have hitherto made, and as will be further evident in the sequel.

“NINTH PROCESS.

“ I had a strong desire to ascertain whether the magnet, when vitrified, retained its power of attraction ; since vitrification is the ultimate limit of chemical operations, and the most effectual means of producing change in bodies. Hitherto I had not vitrified the magnet either by itself or by the aid of borax; although I had exposed it to a very powerful fire for a long time. I therefore added red lead, which, with most earthy bodies and particularly the silicious, changes into a beautiful clear yellow glass, rivalling the Prussian amber in beauty. The first thing to be ascertained was the quantity of red lead required to vitrify the magnet. It was requisite to begin with a very small quantity, in order to be the better assured what was the degree of magnetic force which had survived or had been destroyed. I therefore took three drams each of red lead, magnet, and borax, thoroughly mixed together; I put it into a crucible, and exposed it to a very powerful fire for three hours. The result was a mass scarcely coherent; it seemed as if it would have passed into a solid substance if only more of the flux had been mixed up with it. This was still attracted by the magnet as before; nay, the entire substance was attracted ; the red lead, the salt, and the magnet, all equally. It was evident, therefore, that more red lead must be added; and as

- in the making of glass there is required three times the quantity of red lead as of sand, I added also to the mass three times the quantity of red lead as of the magnet; a dram of borax was also put in. This mass I submitted to a very powerful fire in the crucible for three hours; when



it turned into an opaque glass of a dark colour, very heavy, capable of being poured out, and of being drawn out like glass ; it was also everywhere homogeneous. Thus was the magnet changed into glass, having experienced the greatest change it was possible for it to undergo, if we except that produced by the focus of a burning glass. If the magnet retains its force under this change it will always retain it.

“ This glass, therefore, when brought near the needle, manifestly attracted it equally as much as it did before the mass had undergone the operation in the fire. It was also attracted by the magnet just in the same way as if it had been a real magnet; therefore the glass when pounded into dust was also attracted by the magnet so as to adhere to its poles like a beard. The lead, which was reduced to powder and everywhere surrounded the parts of the magnet, did not impede its forces so much as the small quantity of salt in the preceding processes ; a fact better understood from experiment than from reason, as is the case with many things in natural philosophy.

#### “TENTH PROCESS.

“1. Since antimony is capable of volatilizing nearly all metals in the fire, by penetrating into their most interior recesses, dissolving them into the most minute parts, and carrying them off with itself, I tried the effect of it on the magnet, with a view to make it volatilize as much of it as it could, and leave the rest as an inert and earthy mass. I took, therefore, three drams each of magnet and antimony reduced to powder, which were carefully mixed together and put into a crucible ; these were placed upon an open fire of coal in a blast furnace, for three hours. At the end of this time, the mass, after cooling, was found to be much less in weight and quantity ; but was compact, very friable, and blackish ; it also moved the needle; and when pounded into dust was attracted by the

magnet just as if it had' never undergone any action of the fire.

“ 2. In this mass remained a portion of antimony, which I then wished to expel by a still further process. To this end I took four drams of the former mass ; of common sulphur one dram; of borax of Venice two drams (this salt was used instead of nitre, by mistake); and having pounded and mixed all up together and put it into a crucible, I submitted it to a very strong fire in a reverberating furnace, for two hours. This time the mass was slightly liquefied, became uniform in character, as hard as iron, and of a spongy texture. When held to a needle 6 inches long, at one time it attracted, at another repelled it. In this operation, therefore, the attractive force was not expelled from the magnet.

“3. To this mass, which was again reduced to powder, I added two drams of nitre, with which I again submitted it to a very powerful fire for three hours. From this was produced a black, hard, fragile, and cohesive mass, extremely spongy, porous, and heterogeneous. When brought to the needle, it manifestly attracted it; and even when reduced to powder, every part was strongly attracted by the magnet; although perhaps a little less so than before it had undergone any operation. Antimony, therefore, does not carry off with itself that part of the magnet in which the attractive force resides; although it volatilizes a certain small portion.

#### “ ELEVENTH PROCESS.

“ 1. I now thought it desirable to test the magnet with acid salts, which I had not hitherto used; I therefore put into a glass vessel with a long neck three drams of magnet pounded to powder, and poured upon it spirit of sea-salt to the depth of two digits. This occasioned a great effervescence, from which arose fetid fumes ; large bubbles also were produced in the vessel, just as if the spirit had been poured upon iron filings.

After a time the agitation subsided, and the substance, having been then digested for eight days, produced a tincture intensely yellow ; and in it was contained the whole substance of the magnet in a state of solution, and almost without any sediment. This tincture showed no influence upon the needle.

“ The celebrated Boyle commenced this process, but did not arrive at any important result.<sup>1</sup> He states, however, that he poured a few drops of this tincture on an infusion of galls, which turned the whole into a black ink ; but which, when placed in various aspects, had a blue appearance like the diluted tincture of steel.

“ On this tincture of magnet Boyle poured also salt of tartar, from which resulted a precipitate ; it became similar to a solution of vitriol. On another quantity of this tincture of magnet, he poured spirit of fermented urine, by the aid of which he acquired from a yellow precipitate one of a red colour. But this great philosopher did not examine the forces which these precipitates contained, and, therefore, I resolved to conduct the same experiments with much greater accuracy.

“ 2. From the tincture poured into a retort, I obtained, by the aid of a slow fire, all the spirit of the sea-salt, until there remained a perfectly dry substance; in the course of this operation, I observed that the magnet was half volatilized in the solution of the spirit of salt; for the dry substance did not lodge at the bottom of the retort, but had ascended to the neck. It was likewise of a twofold colour ; the lower part being purple ; the upper, pale yellow ; but the latter appeared to have been the first deposited by the spirit of salt.

“3. I broke the retort and collected separately each substance. Neither of them was in the least attracted by the magnet, nor moved the needle; and both of them in the open air were incapable of retaining their previous dryness. Here again, therefore, the magnetic force was reduced to inaction. At first I expected that it would be entirely

<sup>1</sup> See his *Philosophical Works Abridged*, vol. i., p. 504.—Trs.

destroyed, and would not return again to the particles : the case, however, was the reverse, as will be evident in the sequel.

“ 4. I again mixed both masses together and put them into a vessel, poured water upon them and digested them for two days. There was produced an intensely yellow tincture, of an acid, astringent taste. A blackish powder had also settled to the bottom. I poured out the tincture, and added to the residuum pure water, with which I again digested it ; and there resulted a tincture similar to the former, which I again poured out. Then adding water to the residuum, I produced a fresh tincture, and repeated the operation as long as any tincture could be obtained.

“ 5. All these tinctures, when mixed together and allowed to stay in a vessel for three days, acquired upon their surface a covering with a crystallized appearance, and consisting of fibres perfectly straight, small, and exactly parallel to one another. Meanwhile the yellowish dust had settled to the bottom of the vessel ; this I collected, after having slowly and carefully drawn off the water. This powder, when dried, was of a yellow colour, of a salt taste, acid, and extremely astringent, but was not at all attracted by the magnet.

“ 6. Another powder, which was of a black colour, and which, when slowly dried, had settled to the bottom after digestion and washing in water, as in sect. 4, was in no degree attracted by the armed magnet. This I therefore put into a crucible, and submitted it for two hours to a very strong fire in a reverberating furnace. On cooling, it had a black colour, but contained some small and extremely hard pieces, which had coalesced in the fire as if they contained metal. The whole of this powder was again attracted by the magnet. Its attractive force, however, at the beginning, appeared less than that of the magnetic powder before experiencing the action of the fire.

“ Here then we have the magnet perfectly soluble in a liquid, on which, therefore, it strongly operates with its-

attractive force; since every solution of bodies in a liquid depends on a force of the same kind, and which is reciprocal between the two. Therefore it is not surprising that the magnetic force appears not to act upon other bodies, so long as a solvent is present which so strongly operates upon the parts of the magnet. When, however, the solvent is removed, the forces return to view ; particularly on the approach of another magnet.

“TWELFTH PROCESS.

“ 1. I took three drams of spirit of nitre, made according to Glauber.<sup>1</sup> To this I added three drams of magnet pounded to powder, and put them into a deep vessel; but scarcely any effervescence took place. This I digested for sixteen days ; and there was produced a tincture perfectly clear, but viscous, and verging from a greenish to a yellowish colour; the dust remaining at the bottom of the vessel undissolved.

“ 2. This tincture I gently poured out, and dried the undissolved powder left behind. This being then placed opposite to the pole of a very excellent magnet, showed in various places symptoms of a tendency to attraction. Still it was not attracted, except when placed in immediate contact ; so that in this residuary powder the magnetic force was almost entirely absent. I examined this fact by the following operation.

“ 3. The powder I now put into a crucible, and submitted it to the fire of a blast furnace for an hour, when the powder became red and of a brighter colour than red chalk. When brought near a needle 6 inches long, it neither attracted nor moved it, nor was it in the least attracted by the pole of a very strong magnet, nor in the slightest degree affected.

“ This was, therefore, the inert earth of the magnet, in which no magnetic virtue remained ; consequently the spirit

<sup>1</sup> See Glauber's *Opera, Chymica*. Frankfurt-am-Mayn, 1658, p. 46, *etseq.*—*Trs.*

of nitre did not dissolve it, but only separated it from those portions of the magnet which possessed attractive virtue.

“ 4. I therefore dried the tincture, which yielded a large quantity of a red substance like the *caput mortuum* of vitriol. This, when reduced to powder, was not attracted by the magnet ; a fact which at first surprised me, and led me to think that in this operation the magnetic virtue had been entirely destroyed. But I suspended my judgment, after discovering from the taste that the powder abounded in an acid salt left by the evaporation, which might possibly be the cause of my being misled, and which happened at first in the case of other salts. I therefore exposed the powder in a crucible to a very strong fire in a reverberating furnace for two hours ; the result of which was a powder but little diminished in quantity, of a deep yellow colour, without taste, and which was most powerfully attracted by a magnet; indeed almost as much as iron filings, which are attracted by the magnet more strongly than the powder of a pounded magnet. Truly, therefore, might I say that by this method I had separated some inert portion of the magnet from that which possessed virtue. This portion, however, appeared to me to be merely earth, which possibly I might succeed in changing by other means, but possibly not. I indeed sublimated it with ammoniacal salt, and nearly the whole of the salt was volatilized ; but the earth remained fixed, and had a colour much darker than before ; indeed no part of the earth was volatilized by the salt. I afterwards washed and cleansed the magnetic matter with water, in order that, if from the former operations some of the salt had been left remaining, it might all be removed. The powder when dried had a dark colour ; at first it was slightly attracted by the magnet, but, after it had once, as it were, scented the magnet, which was gently drawn over it, was the most strongly attracted of all the powders hitherto obtained ; and was lifted by the magnet even at a considerable distance. If now we further examine into this subject, we may perhaps

find our labour required. For the analytic method is never unproductive to those who pursue it ; but opens up unexpected discoveries, secures the fruits of fortune and of fame for the student, and by its wonderful results banishes from the mind all the sense of weariness arising from excessive labour.

“ From these various operations it may suffice to learn that the magnet, treated in whatever manner it may be, still remains a magnet; and that neither by fire, nor by dissolving menstrua, nor by salts, can it ever be so far destroyed as irrecoverably to lose its force; since, in spite of all the processes we have here described, it always retained its power, although the salts succeeded in impeding its action. Besides the foregoing, I made other experiments upon the magnet ; they, however, afforded me little satisfaction. I so dissolved it in oil of vitriol, after digestion for sixteen days, that the oil degenerated into a small hard stone, which, when dissolved in water, precipitated a powder of a grey colour, of a salt taste, but strongly attracted by the magnet, and which when placed in a fire for two hours, changed into a red dust, possessing a magnetic force equally as before.

“ The celebrated Boyle dissolved the magnet in *aqua regia* and obtained a solution such as is presented by pure gold.<sup>1</sup> This substance might yet be made to undergo various other treatments, and doubtless would display many beautiful results which would commend themselves to our notice by their utility. This, however, we must leave to time. For ourselves it suffices that we have made some attempts, and that we have made some progress, however small, in this matter.

“ Let us now return to our path, and hasten to other effects produced by the magnet upon iron, which, although we are ignorant of their cause, will nevertheless contribute much to a clearer knowledge of the loadstone. Some of these effects we shall explain by comparing them with others; some we shall only record, since we cannot explain or understand their

<sup>1</sup> See his *Philosophical Works Abridged*, vol. i., p. 504.—Trs.

cause, before we have discovered the cause of the magnetic forces. For a long time I doubted whether I should add the following experiments to the preceding; because they are mostly made by other experimentalists, and do not display great penetration ; besides which, when put together, they do not form any well-arranged series. As, however, it is from the properties of things that we discover their natures ; so also it is by experiments upon the magnet that we investigate the cause of the attractive force. A collection of a great number of data, therefore, is by no means to be rejected; for in these lie all our hopes of solving the problem before us; and the more abstruse it is, the greater number of known data is required to solve and to understand the problem. We have, therefore, extended our experiments over a very wide field ; and although they may be of small value, yet posterity may perhaps derive from them far greater profit than we can, and be enabled to introduce among them a more scientific arrangement; since now only, as Lucretius observes, ‘ In things of this kind many points must be established before you can assign the true law of the thing in question, and it must be approached by a very circuitous road.’<sup>1</sup>

“ It is, however, to be lamented that various things are recorded by authors who have treated of the magnet, which are of doubtful authority ; at least which are incapable of confirmation in these times, in this part of the world, and with our magnets: for philosophers have not made their observations with sufficient care, or have inserted into their writings what they have learnt only by hearsay and have little understood—a circumstance of which Cabaeus complained in the preface to his *Philosophia Magndica*. ‘ I am well aware,’ says he, ‘ that there are many writers, and those by no means of the lowest repute, who have transcribed from others certain plausible statements concerning the magnet,

<sup>1</sup> Lucretius’ *De lierum Natura*, lib. vi., 1. 917-919. Translated by H. A. J. Munro.—*Trs.*



•which, if submitted to the test of experiment, will be found to be in reality untrue.' We ought not, however, on this •account to accuse any one of error who records an observation widely different from our own, for from frequent experience I have learnt how much the phenomena of the magnet differ from one another at various times of the year, or even on the same day, if the observations are made with different magnets. Still, however, philosophers out of their own heads have invented fictions of their own in order to defend an hypothesis once laid down, or to confirm it, as it were, by better arguments; or they have seen in experiments only those particulars which favoured their hypothesis, omitting the others which were also present; for most persons are so led •astray by self-love, that they see only what they wish to see, and what agrees with their prejudices ; to other things they are blind.

“ In order, therefore, to separate from the truth all fable and figment, it was requisite to *go over* the same ground again, and to re-examine the experiments recorded by different authors—a method which sometimes enabled me to detect a not infrequent cause of error, a universal conclusion drawn from a particular observation. Moreover, in the course of my inquiries, I frequently hit upon new modes of investigation, and followed out the attempts which others had only begun. The result of these inquiries will be perceived in the sequel.” (*Op. cit.*, pp. 71-95.)

## CHAPTER X.

### THE FRICTION OF A MAGNET AGAINST IRON, AND THE FORCE COMMUNICATED.

#### A PRIORI OR FROM FIRST PRINCIPLES.

The magnetic parts which are in iron are disposed by means of friction into a regular arrangement; and a magnetic sphere is thus formed around the iron. If the magnet is rubbed against the iron, which is effected by a motion or translation of the magnet in contact with the iron, then not only does experience, but also reasoning *ci priori*, dictate that magnetism is communicated to the iron. By friction the iron is put into contact with the magnet, and all the vorticles adhering to the iron are associated with the innermost, most acute, and most strongly associated spirals of the magnet. The number of these vorticles, and consequently their union, is greatest on the face of the magnet; for if the connection, and spiral or attractive power be strongest at the place of contact with the magnet, then all the vorticles of the same kind near the iron are bound to one another the most strongly; they bend their course into the iron, where they are ready to obey the force of the strongest, that is to say, to follow the direction of the friction of the magnet; and consequently dispose themselves into a most orderly arrangement. Thus fig. 21 (p. 266), if the magnet be drawn from *a* to *b*, then, by reason of the extremely close conjunction of the spirals, the interior vorticles follow the course of the magnet in an orderly and continuous sequence, so as to bend and turn their own path toward that of the magnet from *n* to *o* andy>, as-

in like manner also *qrsb* and *td*; whence arises an orderly arrangement, situation, and emanation of all the vorticles at the surface, so that a sphere with a regular axis can be formed, and the iron itself can be made magnetic. For when the magnet is drawn over the iron, it draws and conjoins to itself the smallest parts ; particularly those which are wholly or partly loose, just the same as it would the filings or pieces of iron, which adhere to and follow the magnet in a long line, presenting the form and aspect of a beard, or of *sty rice* ; so that if a magnetic sphere were rolled over steel filings, all the filings would immediately follow the path of the rolling; the one accompanying the other; the particles would, therefore, form themselves into an orderly sequence, and would follow the motion of the sphere. Consequently we suppose a mass consisting of particles of iron or iron filings, but so arranged that the particles lay loosely and sparsely scattered, and that one but just touched the other; then if a magnet were brought near, there would be no particle that would not turn itself thither, and cast its eyes thither, and obey the slightest movement. Were the magnet drawn along over the length of the mass, the filings would arrange themselves in a corresponding order, and dispose themselves into a corresponding regular sequence. In like manner also when the magnet is drawn over iron, all the smallest particles, or those which can be moved, take an orderly direction, and thus the magnet creates throughout the iron a certain regular configured position of the parts. If again the magnet be moved along a plane surface of iron from C to D (fig. 22, p. 267), then according to the same mechanical rules, the effluvia, particles, or dust of the parts, on whatever side the magnet is drawn, will, in this case, arrange themselves within the iron into an orderly situation ; so that the spirals, motions, and directions of all the effluvia will look from *AyB* and *Eif* toward *CAD* ; and it can be demonstrated that they dispose themselves thus in a parabolic arrangement.

But iron may be rendered very strongly and very per-

manently magnetic, if it is rubbed against the magnet, and thus is in actual contact with it ; but less magnetic, if it is not in contact. If it is placed at a distance from the magnet, it is indeed rendered magnetic so long as it is within the magnetic sphere; but if the sphere is removed, the mechanical order immediately ceases. The more acute are the spirals with which the vorticles coalesce, that is to say, the more closely the magnet is moved to the iron, the stronger is its power of reducing the neighbouring parts into a similar arrangement; for it penetrates into the smaller and more subtle pores. But the farther the magnet is from the iron, or the more obtuse are the spirals with which it is applied, the weaker is its power, because their connection is less-close ; for they penetrate into the wider interstices and pores, but not into the finest; therefore the magnet does not influence the arrangement of the more interior parts. Consequently, at a distance, it acts only in a feeble manner upon the iron and its parts; because it penetrates only into the larger interstices and pores; by which means the iron is indeed attracted at a distance from the magnet, but there is no acquiescence of its parts, no effective force exerted in bringing them into a regular position.

2. Iron is rendered very strongly and very permanently magnetic when all its parts, or its entire structure, are reduced into the same regular arrangement; and less or least magnetic when the parts of the iron are reduced to this arrangement only in certain points, or throughout a shorter distance. For if the magnet touched the iron only in one or in a few given points, the series of effluvia, or of vorticles in the iron, would turn itself toward the points of contact of the iron with the magnet, both to the right and left ; there would, therefore, be no regular arrangement or connection of the effluvia within the iron with those which flow outward; consequently no axis extending to each extremity would be formed together with a connecting sphere. Thus in fig. 44, if the magnet touched only the point  $\sim b$ , the effluvia from  $dg$  perhaps might

direct their course thither, as also from  $h$  and  $i$  ; and consequently there would exist no rectilinear or other series;

Fig. 44.

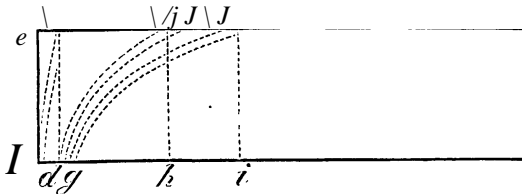

hence also no regular arrangement of the effluvia at the points of the surface  $d$ ,  $c$ , and  $a$ .

3. When the smallest parts in the iron are once reduced by friction into a regular arrangement, they cannot by any further friction be brought into a still more regular order ; nor can the magnetism of the iron be rendered stronger by any repetition of friction. For a figure, once formed exactly and geometrically, cannot by any operation be rendered still more so. The arrangement of the parts, when once attained, still remains the same, though the operation were repeated a thousand times ; nor is any other arrangement produced. Thus, if from a centre we describe a circle, and continue from the same centre to do so a hundred times, we shall describe only the same circle. If by one cause we produce the effect, then if we multiply the same cause a thousand times, we shall produce only the same effect. Hence the mechanism being once acquired by the given figure and arrangement of the parts, if we repeat the operations, we acquire by the same figure and arrangement of parts only the same mechanism.

4. Iron is rendered by friction most strongly magnetic if it has a certain definite mass, thickness, and surface. The size, mass, thickness, and surface, may be determined by experiment; taking into account, however, the nature of the iron and of the magnet. The force communicated by the magnet to the iron, cannot penetrate down to every depth and distance in the iron. All active force in what is contiguous; as it has a

beginning, so it has an end. Motion slackens in proportion to the distance, and has its termination in some arrangement of parts in the contiguous entity. In the elements themselves motion diffuses itself to a distance, according to the force, contiguity, elasticity, and form of the parts. In a contiguous entity there is always resistance ; therefore all motion tends to a state of rest, or to a natural equilibrium. An active, unless it is active from an internal or primitive force, cannot be continually active; for it possesses its own limits, like all other natural things. Thus the force communicated by the magnet to the iron, consisting as it does in motion, cannot penetrate through all iron, at all distances. It is at the point of contact, or where the motion arises, that the force of the motion is greatest; because there it is that the spirals and forms of the motion are the most intimately conjoined. At a distance from the point of contact the motion terminates, as it were, in a state of rest, and degenerates into weaker, slower, and less connected spirals, thus into a settled position of the parts. Within the iron, moreover, the force gradually -diminishes and becomes feebler toward the interiors ; just as is the case with the sphere outside the magnet. For there is a certain degree of force requisite to convert into a state of obedience to itself the partly free and partly connected entities in the iron ; a force which, by reason of the continual obstruction of the parts, becomes gradually feebler. The communicative force, therefore, of the magnet with the iron, cannot extend beyond a given distance, or a definite depth in the iron. If then, the iron has considerable mass, thickness, and magnitude, it cannot by contact receive the magnetic power into itself to any great depth. If a regular figure has to be formed, it must be formed in its totality ; *for* unless it reaches to the bottom or to the other side of the iron, it has at that part no root, no terminus, no end; or inversely, no beginning from which to begin; and since beyond the terminus, the effluvia lie in an irregular direction, and have no regular relation to the surface of the iron, it follows that for want of

a proper boundary the regular figure is disturbed and disappears. For geometrical figures protect themselves in virtue of their own regularity; their abscisse and ordinates, horizontally and perpendicularly drawn, being enabled by their fixed ratios to fortify and defend themselves against any impinging force ; such figures for instance as circles, ellipses, parabolas, hyperbolas, and so forth. But if the figures are not perfectly geometrical, they are not secure from injury; neither are they safe from the impacts of moving bodies. Unless all the parts aim and conspire to the same figure, and are in contact with one another, there is no acquisition of strength by which to maintain subsistence ; particularly when the parts themselves are in perpetual motion. But if the arrangements of the parts are perfectly regular and geometric then one part cannot tend in any direction opposite to the other ; for one keeps the other attached to itself, and always in the same series and same line of connection. Hence it happens that one cannot easily break off its connection unless the other does so. Hence also the whole arrangement, compounded as it is of subordinate and connected parts, cannot be broken up; unless a disruption has first been effected by some other cause acting elsewhere, How hard is it to effect a breach in a ring if it is perfect; but if it is anywhere already broken, how little force is requisite to go on breaking the arc, and causing the sides to collapse. Whatever is well connected together, may, on this account, be able to sustain a weight; but destroy the connection, or let there be a gap between the parts, and the whole is without strength. In like manner, unless the communicative force of the magnet with the iron penetrates to the entire depth, it is void of all durability and strength, a figure is formed without root, base, or limit; consequently incapable of maintaining itself by any connection of parts; therefore it subsists only for a time. In order, therefore, for the iron to be in the best manner invested with the attractive power of the magnet, it must be of a certain mass and thickness ; therefore, if we rub with the

magnet a thicker piece of the iron, it will not admit the attractive force so deeply as if in the same way we rubbed a thinner piece. Hence we conclude that there is a definite form, in order that the magnetic virtue may be fully received within the iron. For inasmuch as the force depends upon the regularity of the arrangement of the parts, unless the surface is regular and of the right form and dimension, magnetism can by no means be acquired. But as one magnet is more powerful than another, and penetrates more deeply, so also is one piece of iron harder or softer than another ; one is pure, another impregnated with foreign substances ; one is new, another is old; one is polished and smooth, another corroded with rust and roughened; one is crude, another is purified from its dross, like steel; in all of them, therefore, there is a different susceptibility to the magnetic influence. Therefore all these things ought to be considered.

musschenbroek's experiments.

#### “EXPERIMENT XXXI.

“ It is generally supposed that any iron, drawn over the pole of a magnet, is impregnated with attractive force. This opinion, however, is rendered doubtful by an observation of an opposite nature made by the celebrated Philippe de la Hire in *Memoires de VAcad&m/ie Royale des Sciences*, vol. x., p. 170. He relates, for instance, that he took an iron rod, 6 inches long and 4 lines thick, to which he frequently applied a powerful magnet, but it did not communicate to it any attractive power, although to smaller rods it communicated a very considerable power. It was evident, therefore, that the iron must be of a certain thickness in order to receive force from the magnet; iron that is very thick being by no means good for the purpose. This experiment appeared to me to be worthy of examination ; in order to ascertain from it in what



way a magnet communicates its forces to iron. Accordingly, I took an iron block, 6 inches long, 1 inch wide, and 1 inch thick. This I drew lengthwise a few times over the pole of a magnet, the weight of which was 1½ pounds, and its power such as to lift from its armature a weight of 7 pounds. To the face of this, as also to its margins and angles, Indian dust and iron ore adhered by attraction. By its edge or margin a very fine needle, scarcely 1/10 of a grain in weight, was slightly attracted ; but it was unable to lift the entire weight. It was evident, therefore, that the iron had become impregnated with a force, although but a small one. We then examined whether, at the same distance, the same mass of iron acquired from the magnet, in the course of a longer time, any greater strength. We therefore let it remain attached to the stone for a day ; and then, after being again plunged into Indian dust and applied to a small steel needle, it exhibited the same attractive forces, without increase; these forces remaining unaltered even after repeated frictions upon the pole of the magnet.

“2. We next procured three cylinders of iron equal in length, each being 4 inches and 1 line in length ; these were terminated at one end by a circular plane, the other extremity being conical; the height of the cones was 1/2 of an inch ; the diameter of the thickest cylinder was 1/2 of an inch. This cylinder was drawn several times lengthwise over the pole of the magnet ; it was then hung perpendicularly to the horizon with its circular base downwards. A new steel needle was then applied, very heavy, but which could be supported, as was ascertained by several experiments ; yet from the flat face a needle which was extremely fine was scarcely supported, even though it was not one grain in weight. A steel needle was also applied to the conical apex of the cylinder inverted, and though it was comparatively very heavy, being 1/10 of a grain in weight, yet it was supported.

“ The diameter of the second cylinder was 1/10 of an inch. This also was drawn lengthwise over the same pole of the

magnet ; but from its circular end a needle weighing only one grain could be suspended, though it hung attracted from every point of the circular surface. When, however, the cylinder was inverted, it was found that from the apex of the cone facing downwards several needles might be suspended, the united weight of which was 7 J grains.

“ The diameter of the third cylinder was  $\frac{1}{8}$  of an inch ; from the circular end of this a steel needle of only one grain in weight could be suspended ; while from the conical apex might be suspended several needles, the collective weight of which was 8 grains.

“ From these four experiments it follows, that the thicker the iron, the less is it impregnated with magnetic force by the same magnet; for it was the thinnest cylinder that received the most virtue, because it supported the greatest weight. Are we then to conclude that the thinner the iron is, supposing the length to be the same, the greater is the magnetic force with which it will be impregnated ? The answer to this question we have tried to ascertain, the result showing that to attract a maximum of weight there must be a definite thickness of iron, all other degrees of thickness possessing less degrees of force.

“ For the smaller cylinder, whose diameter was  $\frac{1}{16}$  of an inch, and of the same length as the former, supported from its conical apex a piece of iron of 4 grains weight; while smaller pieces of iron wire, drawn over the same pole of the magnet, attracted still smaller weights of iron ; consequently there is a given thickness of iron which is invested with a maximum of attractive force by the pole of a given magnet, while all other pieces of iron, whether thicker or thinner, receive less force from the same magnet.

“ The conical extremities, however, of the cylinders at their obtuse apex, appear to collect or to condense the magnetic force, as from these ends a much heavier weight of iron was carried than from the circular and plane surfaces. The cylinders I have described were made with a view to

discover whether, between the thicknesses, lengths, and the forces communicated to them by the magnet, there was any kind of proportion. From these experiments, however, I derived.\_\_\_\_\_

no satisfaction ; as I was ignorant whether, by greater skill on my part and by using other aids, a greater weight of iron might not have been supported by the ends of the cones ; not to mention that variety in the shape of the ends gives rise to great differences between the attractive forces; this is due to some other subtle and latent cause which will be elucidated by further effort in the sequel.

“Let us next inquire into the degree of variation in the communication of the magnetic forces, when the iron is of different shapes. In the following experiments we made use of blocks, the length of all being 4 inches.

“ 3. The width of the first block was  $tW$  of an inch, its thickness  $tVo$  of an inch. This was drawn slowly and frequently, lengthwise over the same pole of the magnet, so as to touch it with its broad side. In this case the attractive force was observed to be so great, that from its flat end a weight of 25 grains was supported. The same block was then applied to the same pole of the magnet, and was rubbed over it frequently in the same direction but so as to touch the magnet with its high or deep side; after which from the same extremity an iron weight of 35 grains was suspended. The magnet therefore communicated to the iron a different attractive force, according to the different side of the iron in contact with the magnet.

“ The width of the second block was  $tw$  of an inch ; its thickness,  $iw$  of an inch ; and when this was drawn lengthwise across the same pole of the magnet so as to touch the stone with its broad side, it was capable of supporting from its flat end a weight of 145 grains. Being next drawn in the same direction across the same pole of the magnet, so as to touch the stone with its deep side, it supported from the same end only 64 grains.

“The width of the third block was  $tW$  of an inch, its

thickness  $t_w$  of an inch ; this touched the magnet with its wide side, being drawn across the same pole, when it supported from its end a weight of 267 grains. Afterwards, however, when drawn across the pole so as to touch it with its narrow side, it attracted a weight of only 57 grains.

“ *Cor.* 1. From these experiments it is evident that the oblong and plane iron was endowed, by the same pole of the magnet, with greater forces than the cylindrical; also that the greater degree of force was communicated to the blocks, (1) because the first supported from its extremity 25 grains, while the second cylinder supported only 7J grains; (2) because the end of the block was a plane surface, not terminating in a point, otherwise it would have carried a greater weight, while the cylinder could carry from its end only a weight of 1A grains; (3) because the weight of the block was greater than that of the cylinder, and its width greater than the diameter of the cylinder.

“ *Cor.* 2. What is the difference of forces communicated to the block, according as they touch the magnet either on their narrow or on their broad side ? We might possibly suspect that iron, drawn both with its narrow and with its broad side over the magnet, would receive a larger proportion of forces than if it were rubbed upon the magnet only upon its broad side. This was apparently observed in the case of the first block ; but in the second and third the contrary obtained ; since in these the forces, which were previously large, were considerably diminished by a friction of the narrow side following that of the broad one.

“ *Cor.* 3. If we compare the attractive force in the block, which was 6 inches long, 1 inch thick, and 1 inch wide, with those of the first block, which was 4 inches long, the one will be to the other nearly as 1 to 50. But if we take into account the thickness of each, then the attractive force of the first piece of iron would be to that of the other as \_\_\_\_\_ to 1. Consequently, if a force was communicated proportional to the thickness, it would follow that the block which was 1 inch

thick, would have to carry about 2 grains, whereas only  $\frac{1}{2}$  of a grain was attracted. There is, therefore, in a given length of iron some given thickness, which is impregnated by the magnet with a maximum of forces : beyond this all thicker as well as all thinner pieces of iron receive only a less proportion of force ; *for* the plate which was 4 inches long,  $\frac{1}{2}$  of an inch wide,  $\frac{1}{2}$  of an inch thick, when rubbed against the same pole of the magnet, received an acquisition of forces by which it sustained only 12 grains.

“ On a consideration of the foregoing experiments, I began to suspect that the magnet was agitated by tremulous vibrations; that it was in these that its force consisted ; that these were communicated to the iron applied to it; and that greater forces were observed in one than in the other, because the vibrations were more easily received and retained. Since, however, flannel applied to vibrating and sounding strings suppresses immediately the tremors and sounds, it appeared to me that it might also diminish or destroy the vibrations of the magnet. Therefore over the pole of the same magnet was spread a triple layer of flannel, and over this again was drawn the third block whose previous forces had been expelled by the action of fire; yet notwithstanding this, it received an attractive force equal to 9 grains. Next only two layers of the flannel were spread over the pole, and the iron was then drawn over the flannel, and received a force able to support 17 grains. Next only a single layer was spread over the pole, and the iron, when drawn over it, acquired a force able to support 47 grains. The magnetic force being next expelled from the iron by means of fire, the block was again drawn over the pole, at a distance of 3 lines from the magnet; and yet it did not receive a force able to support more than 4 grains.

“All these experiments have clearly proved that the forces of the magnet do not consist in any tremor of the parts ; since it communicated them to the iron when it did not touch it, or when the iron passed over flannel which would suppress the

tremors ; and that a communication of the attractive force is made at a considerable distance from the magnet. These circumstances indicate that the magnet remains medially in the sphere of its forces which extend to a considerable distance.

“ 4. Since the experiments made with the former iron cylinders did not satisfy me, I provided myself with six rectangular plates of exactly equal thickness, which was as nearly as possible  $\frac{1}{16}$  of an inch, and as nearly as possible also of an equal length, namely, 4 inches; their width was respectively 1, 2, 3, 4, 5, 6, lines. All these were passed three times over the same pole of the magnet, with the same degree of force, and with equal rapidity; so that all might be equally impressed with the magnetic force. The smallest was the first, which suspended from one of its ends a weight of only 1½ grain.

“The second, which was two lines broad, carried 10½ grains.

“The third, which was three lines broad, carried 15 grains.

“ The fourth, which was four lines broad, carried 20 grains.

“ The fifth, which was five lines broad, carried 25 grains.

“ The sixth, which was six lines broad, carried 30 grains.

“ Now these experiments prove only what we have above intimated ; namely, that to be impregnated with a maximum of attractive forces, iron must be of a definite width ; and that other pieces of iron more or less wide are endowed with a less degree of force ; and that there is no observed constant proportion between the widths and the forces.

“ 5. Finally, we had yet to ascertain whether one piece of iron that was longer than another was imbued with greater forces. I therefore took a plate of iron of the same thickness as the six former ones, 5 lines wide, 13½ inches long; and drew it across the same pole of the magnet three times, as in former cases. This carried from its end an iron weight of 25 grains. The plate was then shortened so as to be only 10 inches long; and when again drawn three times over the same pole of the magnet, carried 33 grains; when shortened

to 9 inches in length, it carried only 19 grains; when shortened to 8 inches, it carried 17 grains; and when shortened to 4 inches, it carried only 1J grains.

“ From this experiment it is likewise evident, that if the iron be of a given width and thickness, the longer piece is impregnated with a greater degree of force than the shorter; that it is only when we arrive at a certain given length, that it becomes endowed with a maximum of force; and that if the length of the iron be altered, so as to become either greater or less, the iron receives from the magnet a less degree of force. In the foregoing case, the greatest difference of forces was observable between the length of 10 and the length of 4 inches; for the latter sustained a weight of only a grain and a half, while the other sustained a weight of 33 grains. Nor does there appear to be any proportion between the length of the iron and the amount of the force.

#### “EXPERIMENT XXXII.

“ A well tempered steel plate, 4 inches long, 10 of an inch wide, 10- of an inch thick, was drawn three times over the pole of a magnet, slowly, and with a given degree of pressure ; after this it carried an iron weight of 72 grains. Another plate of soft iron, exactly similar and equal to the former, was also drawn three times over the same pole of the magnet with the same degree of pressure : this from its end was only able to sustain a piece of iron of 10 grains. The rubbings with the same magnet, when repeated, did not communicate to the iron any increase of force; so that the magnet communicates to steel a much greater degree of force than to iron; and indeed, according to this experiment, seven times as much. Whether the same proportion obtains in other bodies of equal dimensions, made respectively of steel and of iron, I do not pretend to say. Many authors have remarked that the magnet communicates more virtue

to steel than to iron ; but not one of them has determined the exact proportion. Doubtless there will be much difference according as the steel is pure or impure; according also to the nature of the iron, whether taken from the mines of Sweden, or from the mines of Germany.

“experiment xxxiii.

“The magnet attracts iron more strongly than it does steel; and soft steel more strongly than hard; and hard steel more strongly than the hardest.

“ I remember that Hartsoeker has made the same remark; observing, that if a magnet can lift an iron ruler of the weight of three ounces, it will be able to lift a ruler made of the softest iron weighing at least four ounces. Dechales<sup>1</sup> indeed maintained the contrary; unless we suppose that he was giving his opinion on magnetic forces communicated to a larger quantity of steel, as was intimated in a preceding experiment.

“EXPERIMENT XXXIV.

“ There are some magnets which communicate to iron a greater degree of force than others ; nor do those which the most strongly attract a large mass of iron, or which are themselves the largest, always communicate as much virtue to the iron as the smaller and weaker.

All makers of the mariner's needle have observed this for a long time; they are therefore always on the look-out for what they call *liberal* magnets, although they do not attract any large mass of iron. I made an experiment with a most excellent magnet, whose force was manifested at a distance of 13 Rhenish feet; and which, had it been well

<sup>1</sup> *De Magnete* (Cursus seu Mundus Mathematicus. Lugduni, 1690, vol. ii., p. 473).—Trs.



armed, would probably have supported 50 lbs. or more in weight of iron. On the north pole of this magnet were rubbed iron plates, the magnetic power of which was afterwards ascertained by hanging small weights to their ends. These plates being subsequently heated in order to deprive them of their acquired magnetic force, it was found that a much greater attractive force was communicated to them by a small and weak magnet which was capable of lifting only four lbs. In performing this experiment, I took care that the iron should be drawn over the same poles of each magnet, with an equal speed, pressure, and number of times; but I could not come to any exact conclusion. Whiston confirms this remark by his own experience, as well as by that of the excellent Fatio and Colonel Windham.<sup>1</sup> He, however, gave his attention to the rate of the vibrations with which the same needle oscillated, when rubbed against different magnets; and he remarked at the same time that the directive force was not imparted to a needle by a large magnet better than by a small one. We are, however, to observe that, for the most part, the stronger magnets communicate to iron a greater force than the weaker.

“ From this experiment it seems to follow that in all magnets the forces do not exist after the same manner; that one kind may be received by iron more easily than others. For it is extremely probable that the stronger magnet emits from itself more forces than a weak one; otherwise how could it be the stronger? or how could it carry the greater quantity of iron, unless it diffused from itself the greater multitude of forces? These forces, however, are not received by the iron always in so great a quantity as those which flow from a weak magnet, and which are less in quantity. Consequently the forces of some magnets more accord with the structure of the iron than the forces of others.

“ In like manner there is also iron which receives little force from the magnet; while, at the same time, there is

<sup>1</sup> *Longitude and Latitude Found*. London, 1721. Preface, pp. xx-xxi.— *Trs.*

other iron which may be endowed by the same magnet with a greater force.

“experiment XXXV.

“ If a piece of iron be drawn once very suddenly over a magnet, it acquires a certain degree of force; if the rubbing is repeated upon the same part of the magnet, and in the same direction, by raising the iron from the magnet, then, when it is drawn to its full length, the force is increased in the iron ; until after repeated rubbings, it has received all the force of which it is capable. For afterwards friction frequently repeated upon the same magnet imparts to the iron no further force.

“ This is confirmed by Sturm in his *Physica Electiva: Norimbergae, 1697-1722*, vol. ii., p. 1090. In this experiment the iron acquires only certain given forces from the magnet, and no more, although rubbed against the stone a thousand times; a fact which does not result from any inability to receive greater forces; but because the magnet cannot impart to the given mass any greater or more ; for were the iron drawn over a more liberal magnet, it would acquire a greater force of attraction.

“If the iron has not been drawn over the magnet, but only applied to it, then it does not become impregnated with the magnetic force, till after the lapse of some hours, as the celebrated Wolff has rightly observed ;<sup>1</sup> nor by this method is it made to receive so great a force as if it were drawn over the magnet. Since, therefore, the mere application of the iron to the magnet, or a rapid drawing of it over the magnet, does not communicate to the iron so much force, it is better to rub the pole of the magnet slowly with the iron and with a strong pressure.

<sup>1</sup> See his *Vernunfftige Gedancken*, § 382.—Trs.

## "EXPERIMENT XXXVI.

" If iron is rubbed against a strong and liberal magnet, it will receive from it a considerable power of lifting other iron ; if it is again drawn over the pole of a magnet possessing weaker forces, it will lose a considerable portion of its former force, and lift a much less quantity of iron, possessing only the degree of force which the weaker magnet had communicated to it.

## "EXPERIMENT XXXVII.

" If an iron plate drawn leftwards over either pole of a magnet, is imbued with attractive force and afterwards is drawn to the right, it will lose the greater portion of the force which it had acquired from its former movement; while that which remains will lodge in that end of the plate which last touched the magnet.

" The iron, therefore, must never be rubbed against the magnet so as to be drawn both to the right and left; since after repeated rubbings in this manner the iron will not be found to have acquired any virtue. This was formerly observed by Barlow,<sup>1</sup> and Riccioli in *Geographice et Hydrographice Reformatoe* : Bononise, 1661, p. 338. Moreover, it has been observed by the learned Derham, that iron thus rubbed, has its poles not in the extremities, but in or near the centre. Sometimes one pole is near the centre and the other at one of the ends. Sometimes both ends are attracted by the same pole of the magnet, and are repelled by the other pole. In this case the repelling pole always found the attracting part near the centre. In other pieces of iron he observed that the directive force acted in the opposite way, and that their ends were plainly attracted and repelled in a manner contrary to the natural one. *Philosophical Transactions*, vol. xxiv., pp. 2136-2144.

<sup>1</sup> *Magneticall Advertisements*. London, 1616, p. 60.—Trs.

## “ EXPERIMENT XXXVIII.

“ When the forces exercised by a magnet upon iron removed to a given distance are accurately ascertained according to our system of adding weights, then if several iron bodies are rubbed against the stone and impregnated with the magnetic force, and if the force of the magnet upon the iron is immediately examined in order to ascertain whether it has remained the same or decreased, it will be found that it has constantly continued the same without any decrease.

“ Several persons have recorded this observation ; such as Norman, in *The Newe Attractive*, chap. i. pp. 1-6 ; Gilbert;<sup>1</sup> and Hartsoeker, who on one occasion expressed to me his regret, that having been led into error by the assertions of Joblot, he had said the contrary in his writings; for magnets never lose any of their force, although on the same day several pieces of iron be applied to them.

“ This we perceive, therefore, to be a great paradox; for if the magnet communicates as much of its own force to the iron as the iron receives, then a plate of a definite size would frequently acquire | of the forces of the magnet, and hence 8 plates would receive a force equal to that possessed by the magnet; and 64 plates, 8 times the force of the magnet; in other words, the magnet would be deprived of 8 times its force. But the magnet always retains the same force, even though within the space of an hour not only 64 but double the number of pieces of iron are drawn over it; nay, as is observed by Norman, even though it were rubbed by 1000 plates or needles.

“ Is the magnet, therefore, continually acquiring from some other source a new force, equal to that which it communicates ? For its communication of forces cannot be the consequence of effluvia emitted from itself, because such an equable and sudden generation of effluvia as is required cannot take place; since many pieces of iron may be applied to

<sup>1</sup> *De Magnete*, lib. iii., cap. iii.—Trs.

it within a very short space of time. What then is the source of these attractive forces which so copiously and equably accrue to the magnet that it loses nothing by rubbing ? Is it not rather that the stone communicates nothing of its substance to the iron, but only excites a force which is always latent in the metal ; and from a state of rest, brings it into a state of action ? For it sometimes happens that iron when drawn over the magnet will lift a greater weight than the magnet itself; as La Hire has observed in *Histoire de V Academie Royale des Sciences*, 1717, p. 5, and *Memoires*, p. 275. Does this excess of forces in the iron above those of the magnet arise from the iron or from the magnet itself ? If from the magnet, there will be less in the cause than in the effect; which is absurd. But if there be latent in the iron a greater force, which the magnet only brings out into act, we may in some measure understand how it is that the magnet excites a force in innumerable pieces of iron on the same day. Still this supposition cannot be proved.

“ EXPERIMENT XXXIX.

“ The magnet attracts pure iron more strongly than when rusty ; because rust is a kind of vitriol, or salt mixed with particles of iron. We have, however, in our chemical analysis of the magnet, previously shown that salt coerces the magnetic forces, and reduces them to inaction; the force of the magnet, therefore, does not act with such great efficacy upon rusty iron as upon pure. Consequently, I can by no means agree with Tachenius, in *Hippocratice Medicince Claris*, Francofurti, 1669, cap. ix., p. 256, who thus explains the matter, that from rust is given off the acid of iron, and that on this account the mater (or the magnet) does not perceive the odour.

## “EXPERIMENT XL.

“ An unarmed magnet, able to support an iron mass of two ounces, the greatest weight it can sustain, will not be able to lift a piece of iron of one ounce weight together with another piece of iron of one ounce weight; although its surface is similar to that of the former mass, as Dechales has rightly observed.<sup>1</sup>

## “EXPERIMENT XLI.

<sup>u</sup> If a magnet is divided by a file into several parts, so as to avoid any concussion of the interior structure, then the sum of the weights of the iron which all the fragments separately sustain, will considerably exceed the weight which was before lifted by the magnet when whole.

“A large magnet is seldom able to support its own weight. I have known, however, many small ones possessing an attractive power capable of lifting ten or twenty times their own weight, and even more. I have seen very small magnets, whose lifting power was fifteen times greater than their own weight. But because a large magnet may be considered as a collection of several small ones conjoined into a single mass, so these do not exercise so much force upon iron conjointly as they do separately. For it has been shown in experiment xvi. that the force exercised by the magnet upon the iron decreases in proportion to the increase of the distance. Thus in fig. 45,

Fig. 45.

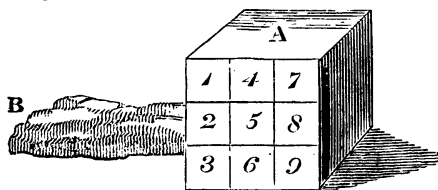

let A be ' a magnet able to support the iron B. Let it be

<sup>1</sup> *De Magnete* (Cursus seu Mnndus Mathematicus. Lugduni, 1690, vol. ii., p. 488).—Trs.

conceived to be divided into nine parts, as shown by the figure : it will be at once seen that the iron B is immediately applied to the parts 1, 2, 3 ; but it is distant from the parts 4, 5, 6, by the thickness of the parts in the first series ; wherefore these act upon the iron only in the same way as the magnet would have acted, if removed to the same distance from it. But inasmuch as parts 7, 8, 9 are much more distant from the iron B than the middle series, these again will influence it still less. Yet by their force they will assist the action of the first series upon the iron. But if the nine parts had been separated from one another, and the iron had been applied directly to each, then being in contact with each part the iron would have been attracted with its greatest force ; so that the sum of the weights attracted by these nine parts would considerably surpass the weight carried by the united mass A. The smaller the parts into which A is divided, and to each of which the iron is presented to be lifted, the greater will be the weight elevated by all together. But the greater the mass A, the more distant are the posterior parts from those to which the iron is applied, and therefore the less can they influence it.

#### “EXPERIMENT XLII.

“ The larger magnets are, though not of particularly great power, the greater is the distance to which they diffuse their forces. Consequently, excellent but small magnets do not so widely extend their power as the large though more inert ones. This is confirmed by Hartsoeker, who says he learnt it from experience; therefore three or four magnets, well joined together, act at a greater distance than each separately.

“ The attractive force is frequently diffused to a great distance from the stone. I made some experiments with a very large magnet, which showed force at a distance of 14 Rhenish feet. The two following are excellent methods of

ascertaining to what distance from the magnet the force extends itself. 1. Place an extremely fine needle of steel upon the surface of water put into a vessel, so as to float in the middle ; next let a magnet be placed at a considerable distance, and then be gradually brought nearer, so that the line passing through the poles may point toward the needle. Let the magnet continue to approach, till the needle begins to move; it will then float toward that wall of the vessel which is nearest to the magnet. 2. Let an extremely sensitive needle, 6 inches or more in length, be placed in its meridian; marking the degree to which its end points ; then let the magnet, placed at a considerable distance, be gradually brought nearer, so that the axis may be perpendicular to the needle and in the same horizontal plane, until the needle begins to be deflected from its position ; the distance between the two will be the length to which the magnetic forces are extended, or the length of the active ray. This method has been mentioned also by Fontenelle, in *Histoire de l'Academie Royale des Sciences*, 1717, p. 5, (in summarizing La Hire, at *Memoires*, p. 275).

#### “EXPERIMENT XLIII.

“ Various fragments of magnets may be joined into one mass, which will exercise considerable power; provided that lead be poured in between and round the parts. These fragments require to be arranged in such an order, that the poles of the same name look in the same direction; for in this case, they are disposed in the same manner as the parts of the large magnet would have been by nature. Thus art, imitating nature, constructs the larger mass out of small pieces. This was known to Dechales<sup>1</sup> and to many others, who verified the same by experiment.

<sup>1</sup> *De Magnete* (Cursus seu Mundus Mathematicus, vol. ii., p. 486).—Trs.



## "EXPERIMENT XLIV.

"It sometimes happens that a large magnetic mass does not show much attractive force; when, on the other hand, the same, if divided into many fragments, exhibits a small portion of itself endowed with considerable forces, upon which, as upon a heart situated in the middle of the stone, depends the whole force of the magnet; this, being previously dispersed throughout the larger mass, had either been prevented from issuing out, or else, because it was distributed in every direction through the mass, had weakened the poles." (*Op. cit.*, pp. 96-108.)

## CHAPTER XI,

### ON THE ATTRACTIVE FORCE OF A MAGNET ACTING UPON SEVERAL PIECES OF IRON.

#### A PRIORI OR FROM FIRST PRINCIPLES.

One magnet is able to attract to itself several pieces of iron together, and inclose them all within one and the same sphere. For if from the two spheres of the magnet and of the iron there arises a larger sphere, which incloses both the magnet and the iron, and which penetrates the iron, conjoining and attracting it to itself, then it follows that from several spheres a larger one may be formed, and thus that innumerable pieces of iron may be mutually joined together, and made to follow the same magnet, as if tied and bound to it.

2. The conjunctive or attractive force of the magnet may increase, and be greatly augmented by the application of iron, or by an armature. From two or more spheres there exists one that is larger; therefore, by the application of iron, the magnetic force receives an increase. Moreover, a magnetic body is not so coherent and compact as an iron one. For when iron is moved towards an unarmed magnet, then, because of the want of compactness in its structure and the loose coherence of its parts, it cannot become attached thereto. There is a double cause, therefore, for the accession of force to the magnet by means of an armature.

3. There cannot be two magnets absolutely Eke each other as to their conjunctive force, as we have before stated. For there are some which are surrounded with a large and perfectly regular sphere; some with a large but not regular sphere ; some with a large but lightly compact sphere; some are

generous and noble, some worthless and without power; some energetic and quick, some tardy and sluggish ; some exceedingly pregnant and rich with forces, some poor and sparing in their communication of forces. Some, like iron, act at a considerable distance ; some will not act at a distance, but powerfully affect adjacent objects. These differences are due solely to the quantity of the iron parts, and the regularity of their arrangement. We shall not go over the same ground again; but shall content ourselves with this simple statement of the differences.

musschenbroek's experiments.

"experiment xlv.

" Fig. 46. Over a good and large magnet A, let there be held, at some distance, two iron keys B and C, which have not been magnetised before. From the key C let BK be suspended (these two are sometimes supported by a third key D). If D, together with the adhering keys C, B, be raised to a greater distance from the magnet, they will separate from one another and fall. The keys, however, may be moved to a considerable distance from the magnet before they separate from one another; for it is observed by Derham, in the *Philosophical Transactions*, vol. xxiv. p. 2139, that the magnet of the British Royal Society had suspended two keys at the distance of 8, 9, or 10 feet from itself.

Fig. 46.

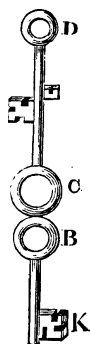

" In this experiment we observe that the attractive force of the magnet passes through the iron itself, and thus extends to a considerable distance. Still it is surprising that the key BK is not attracted by the magnet A so strongly as by the key C; for it will adhere to the latter, but not to the magnet. Yet the magnet is the cause of the attraction ; for the keys separate as soon as they are removed farther from the

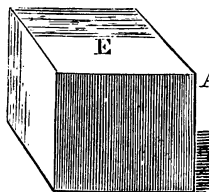

keys separate as soon as they are removed farther from the

magnet. Why then does the key C, which is distant from the magnet, attract the key B more strongly than does the magnet A ? Some, perhaps, may suppose that the key B is not attracted by the magnet\* but is repelled against C ; but this is not so ; for B is most strongly attracted by the magnet, as will be evident from the following experiment. If the pole of the magnet be at E, and if the key B be carried round it in a circular direction, but at a considerable distance, namely, in the periphery of a large circle, the lower part K will be drawn toward E, and the whole key will take a very oblique position, and appear in its motion to describe the surface of a cone. In the course of this experiment, moreover, it is observed that if the axis of the magnet is perpendicular to the horizon, the keys may be raised above the magnet higher than is possible when the axis is parallel to the horizon, without losing their attraction ; and if the north pole of the magnet is turned upwards, then the keys may be raised to the greatest distance from the stone of which they are capable, without interfering with their mutual coherence.

## EXPERIMENT XLVI.

Fig. 47. “ Fig. 47. If a number of small iron spheres C, D, E, applied one to the other and suspended from each other, are attracted by the pole C of the magnet PC, in a rectilinear series perpendicular to the horizon; and if the similar pole B of another magnet BS, is slowly brought toward the lower sphere E, from which it has been removed to a considerable distance, it will separate the globe E from D, and will repel the entire series of globes DC, by giving it an oblique position.

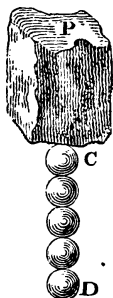

“We always observe that the similar poles of two magnets repel each other. This being granted, the pole C of the magnet CP attracts to itself the series of spheres E, D, C, in a

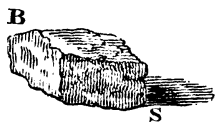

direction from E to C ; and thus all the lowest parts of the spheres

will have poles similar to C, and the uppermost parts will have poles similar to P. If, therefore, the pole B of the magnet BS be of the same kind as C, that is to say, like the lowest parts of the spheres, then all these must be repelled by the pole B. If the repelling force of B be greater than the attracting force of the pole C exercised upon the farthest globe E, upon which it can act but slightly, then the sphere E, repelled too much by the pole B, will be separated from the others. Instead of the iron spheres, the same experiment may be very well performed with needles, which, suspended by their ends and adhering one to another, will constitute a series. If the magnet BS be moved round the lowest, it will repel it, and impart to it a circular movement, as Wolff has excellently remarked in his *Vernunfftige Gedancken*, § 382. But if the pole S of the magnet BS be presented to the lowest needle, the latter will immediately fly to it.

“ EXPERIMENT XLVII.

“If to the pole of the more powerful magnet an oblong piece of iron is applied, lying in a smooth horizontal plane, and if a pole of another name, but of a weaker magnet, is applied to the other extremity of the iron; then, if the latter magnet is drawn slowly backward, so that the iron remains in the plane, the iron will often adhere to it; being forced away from the stronger magnet.

“ There are many who have observed this phenomenon; as for instance, Kircher in his *Magnes*, Lib. i. theorema xxxiii. p. 141; Gassendi, *Animadversiones in Decimum Librum Diogenis Laertii*: Lugduni, 1649, vol. i. p. 387; Rohault, in his *Physica*, par 3., cap. 8., § 54 ; La Hire, in *Histoire de VAcad<sup>m</sup>ie Roy ale des Sciences*, 1717, *Mem.*, p. 275.

“ EXPERIMENT XLVIII.

“ If a magnetic needle is placed in the equator of a spherical magnet parallel to the axis of the magnet, and if an iron ruler is applied to the extremity of the needle ; this ruler will adhere

to the needle so firmly as to be enabled to draw it round the whole of the magnet, and bring it into any position.

“EXPERIMENT XLIX.

“ Fig. 48. If to a magnet A of good power, a small iron sphere B adheres by attraction; and if an iron ruler CD touches that point of the sphere which is opposite to the point of contact with the magnet, the ruler CD

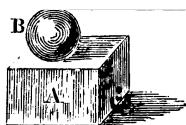

will be able to draw the sphere away from the magnet; but if the magnet be of less power, then the ruler will be unable to do this. La Hire,<sup>1</sup> who made

this experiment with two iron rulers, the smaller of which was that which adhered to the magnet, says that the large ruler did indeed draw away the smaller from the magnet; but that both were separated after being withdrawn from the magnet two or three inches.

“EXPERIMENT L.

“ The point of a steel needle was blunted, but so that the head still remained the thickest part. The point was then applied to a very powerful magnet, and the head to an iron rod. When the rod was drawn away from the stone, the needle continued to adhere firmly to it and left the magnet. The head of the needle having been applied to the magnet, and also the point to the iron rod, the needle was sometimes drawn away from the magnet, and sometimes not, when the ruler was drawn back as before.

“ The point of the needle was then made very sharp ; and the head was highly polished: in this case, when the point was applied to the magnet and the head to the iron ruler, the needle kept adhering to the latter, and could thus be drawn away from the magnet. But when the head of the needle was applied to the magnet and the point to the ruler, the needle did not adhere

<sup>1</sup> See under experiment xlvii.—*Trs.*

to the ruler, but remained attached to the magnet. At first appearance, therefore, I thought, with other philosophers, that the needle adhered to that body which it touched in the greater—number of points. This opinion, however, I have found from many experiments to be erroneous; for a key whose degree of polish was considerable, was placed on the plane pole of the magnet, so as to be in contact with it throughout a considerable portion of surface; and the round head of another key was applied to the round head of the former key, so that the contact of the two might be only in one point; nevertheless, the second key drew the first away from the magnet. This experiment I made together with Hartsoeker, who affirms that in every case he observed the same paradox; as is noticed also by La Hire, in *Histoire de l'Académie Royale des Sciences*, 1717, *Mem.*, p. 275. He supposed that iron acted as a stronger magnet in attracting iron than the magnet itself; and that for this reason one iron ruler took away the other from the magnet. This, however, appears to be too hazardous an assumption; since iron that is endowed with scarcely any magnetic force draws away another piece of iron from a most powerful magnet. Moreover, the difficulty is not solved as to the manner in which a weaker magnet draws away the iron from a stronger one, as in experiment *xlvi*. One philosopher indeed supposes that the weaker magnet acquires a force from the stronger; but it has still to be demonstrated that the weaker becomes stronger than a very powerful magnet; whether this can be conceded or conceived, I very much doubt. Many indeed are the phenomena of magnets; yet how few of them can be understood by an intelligent mind, is evident from experiments *xlvi* to 1, experiments which may be classed among those that are the least comprehended of all.

#### “ EXPERIMENT LI.

“ If a number of common needles, or small iron plates, are arranged together in a series close to one another; then, when

the magnet touches one needle or plate, they will all adhere to one another and to the magnet: but the second will adhere to the first more strongly than the third to the second, adherence becoming less in proportion as the needles or rods are more distant from the magnet. The force of the magnet therefore passes from one piece of iron into the other; or, if the magnetic force is excited in one piece of iron, so also it is in the next, and thus onwards to the last. Effects analogous to these may be seen in two rotating iron wheels, one of which touches the magnet and the second is suspended from the former, so that the two are in contact at one point, and cohere in virtue of the attractive force of the magnet. In this case each wheel may be swiftly rotated in a direction opposite to that of the other, and yet the rotation will be found not to interfere with the attraction.

#### EXPERIMENT LII.

“ If a plate of iron is rubbed lengthwise along a magnet, the part which last touched the magnet has more strength than the part which was first applied; so that, in order that the weaker end of the iron may receive the same force as the other, it must be rubbed upon the opposite pole of the magnet.

#### “ EXPERIMENT LIII.

“ If a well tempered steel ruler is cut into several rectangular parts; if these again are placed upon a copper plate, in an order different from the one in which they before cohered ; and if they are well pressed together, so as to form as it were a united body ; if in the next place a magnet is pressed closely down upon them, then the ruler will be endued with a force which will be greater in proportion as the parts the more closely touch one another; but if these scarcely touch one another then only a slight degree of force will be communicated.



“ EXPERIMENT LIV.

“ Fig. 49. Let the needle CD, attracted by AB, the magnet placed above it, stand perpendicularly on the table D, let the— needle FG be then moved across, so as to pass between the needle CD and the magnet AB; the needle CD will then immediately fall, the attraction no longer continuing.

Fig. 49.

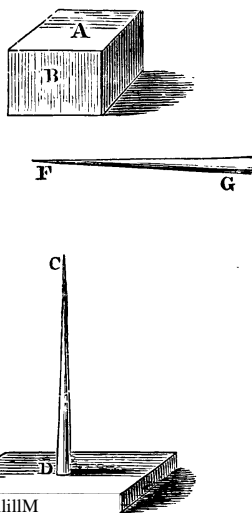

“We see then how much, and how easily, the magnetic force may be deflected from its path, by the operation of a very slight cause. For the needle FG takes away all the force which was before directed to CD, and deflects it to FG. Now any person acquainted with the motion of water and of fluids may easily see that this phenomenon differs from all the laws of moving fluids; consequently, that the magnet does not operate by effluvia, or by any other kind of fluid.

“ EXPERIMENT LV.

“ An iron plate, which was drawn over a very powerful magnet, became impregnated with a considerable force. It was then placed on an anvil, and hammered for some time. At length it lost all the force it had before received from the magnet ; for it could carry only the lightest particles of grit or ore; this being due to the force of the hammering, and such indeed as all iron experiences from the same cause; it was unable, however, to lift even the lightest needle.

“ Grimaldus,<sup>1</sup> in the course of his physical observations,

\ See *Plyisico-Mathesis de Turning Coloribus, et Iride*. Bononise, 1665, prop. vi. sect. 45.—*Trs.*

makes mention of a similar result from the same experiment. But what is it that thus expels the forces from the iron ? The parts of the iron are separated from one another by hammering, the pores are changed, a contact between other parts is effected ; and though in the iron no other change takes place, yet this alone is sufficient to disturb and dissipate the magnetic forces so that none remain. Is then the figure of the pores the cause of the attraction or of the magnetic virtue ? Assuredly not; for what is a pore but an empty space naturally inert ? But when the arrangement of the parts is changed, is there not force expelled ? and since the hammer acts upon this force, must it not be a material substance ? That one body may act upon another is intelligible enough ; but how it can act upon substances altogether diverse is incomprehensible. Yet we see the body act upon the mind, which is something perfectly distinct from the body. May it not be, in like manner, that the blows of the hammer act upon the magnetic force, even although the latter may not be a material substance, but one of a different nature, yet having a relation to the former similar to that which exists between the mind and the body ? But inasmuch as we observe iron filings, endued with magnetic forces, immediately lose them when the parts become intermingled, are we to conclude that hammered iron in the same way loses its forces, because the different parts become intermixed one with the other and are arranged in a different order ? This indeed appears to be highly probable. Still the difficulty remains as to the manner in which the forces are destroyed by the disturbance of the arrangement of the parts.

“ EXPERIMENT LVI.

“ If a plate of iron, which has been rubbed against a very powerful magnet, is impregnated with considerable magnetic forces ; and if it is heated so as to become red hot, and in this state be applied to iron filings, it will not attract a single particle, —a manifest proof that there does not remain in the heated plate any attractive forces. This agrees with experiment xxix.,

relative to the magnet heated in the fire, and which lost the power of attracting iron filings. Thus the iron does not differ from the magnet; nor is the magnetic force in the iron different from that in the magnet; if, therefore, the fire expels the force from the one why does it not expel it from the other? Here then we see how surprising are the properties of the magnetic force! At one time the fire acts upon it, at another it does not act; for the force passes unimpaired through the flame of spirit and oil, yet is expelled and destroyed by fire in the case of iron and stony bodies.

“EXPERIMENT LVII.

“ Since an iron plate is deprived of its magnetic forces in the fire, we must ascertain whether the magnet will communicate its force to heated iron; and whether when thus communicated it will remain in the iron. At first sight it might be thought that this experiment was unnecessary; for if in experiment lvi. the fire expelled the magnetic force from the iron, it would also now expel from it any force it had received; for the fire which exists in highly incandescent iron does not differ from any other fire; and yet how contrary are the phenomena to such a course of reasoning! This fact ought to teach experimentalists how slowly and cautiously they should proceed in physics; and how little we ought to trust to experiments, unless frequently repeated by the most skilful manipulators. Indeed, in this science, the adage inculcated by chemists will be found to apply, ‘ All haste is of the devil ’; for haste, combined with abstract argument derived from one or two observations, cannot but lead constantly into error. In the year 1725, a plate highly heated was drawn over the pole of a good magnet, and plunged into iron filings; yet it gave no indications of attractive force. The friction upon the magnet was repeated, but no force was communicated to the iron; after the plate had cooled, it possessed no greater power of attraction than any other plate. In the year 1727 I repeated the same experiment before numerous spectators, with another good but armed magnet. The same

iron plate was strongly heated; it was then drawn along over the foot or pole of an armed magnet, and plunged into filings, when it showed a strong attractive power; the filings adhered on all sides like a beard ; nay, even when cold, the iron retained the same degree of strength. Wondering at a result so unexpected and so contrary to the former, I repeated the experiment on the following day with a piece of iron wire. I took also a fresh quantity of filings, and carefully attending to every particular lest I should fall into any mistake, I arrived nevertheless at the same result; for the iron wire, when heated, was still impregnated with the magnetic force, and retained it even after it was allowed to cool. Now what conclusion can we draw from results so opposite ? Is it that some magnets are enabled to communicate their force to heated iron, and others not ? or is it that at one season of the year a phenomenon may be produced which at another cannot ? Has the armature anything to do with it ? Does it in any measure depend upon the exact temperature ? does it depend upon the iron ? It is important to be cautious in reasoning from experiments of such a nature.

#### “ EXPERIMENT LVIII.

“ A magnet was placed on a whirling table. On another table was placed a mariner's needle, 10 feet distant from the magnet; so that the axes of the stone and of the needle were in the same horizontal plane. The needle was brought into a state of rest; the table with the magnet was then turned round, and a motion of the needle was observable ; but before it began to move there was an interval of rather less than two minutes. The magnet was then brought nearer to the needle, the table on which it was placed being now 7 feet away; and, when again revolved, the needle also moved; but between the beginning of the motion of the magnet and that of the needle the time was shorter than before. The magnet was again brought nearer to the needle, there now being between the two an interval of only 3 feet. As soon as the magnet was rotated

the needle moved; nor was any delay in the motion of the latter now observable. The time between the motion of the magnet and that of the needle was too short to enable me to take any accurate observation of it; but I carefully noted the proportion between the times in which the motions of the needle took place, and the distances of the two bodies from each other, in order to ascertain the velocity of the magnetic forces. Hitherto, however, the velocity has been too great for me to come to any accurate conclusion upon the subject. Still the attempt, such as it was, appeared to me to be too worthy of notice to allow it to be passed over in silence.

“EXPERIMENT LIX.

“ If a needle and a magnet be placed at such a distance that the one acts upon the other, the needle is attracted by the pole of the magnet; that point of the needle which has not the same name being directed toward the pole. If now a second magnet be placed near the first, in the same horizontal plane, and at the same distance from the needle, so that the poles of the two magnets looking in the same direction are similar; the needle will be directed toward the middle of the space left between the magnets and where the centre of the magnetic forces lies ; just as in the case of two separate bodies, the centre of gravity lies between them. But if the pole of the second magnet which was placed near the first be of another name ; the needle observes a direction perpendicular to the axis of the two magnets ; for its point is attracted by one pole in the same degree in which it is repelled by the other.

“EXPERIMENT LX.

“ Fig. 50. On the table AB, which could be rapidly rotated by the wheel P, the magnet C was fastened, having its axis perpendicular to the horizon and its north pole upwards. A magnetic needle was then placed upon another table which

was fixed, and in the same horizontal plane with AB ; this needle was also covered with a glass bell, lest it should be disturbed by the motion of the air produced by the rotation of the table AB. The needle was then moved so near the magnet C as to be within the sphere of its influence. The needle being at rest, the table AB was rapidly revolved. At first the needle appeared to oscillate right and left, for a while abandoning slightly its original position. But when the velocity of the table AB was increased as much as possible, the needle remained fixed in its meridian, nor showed the slightest sign of motion.

Fig. 50.

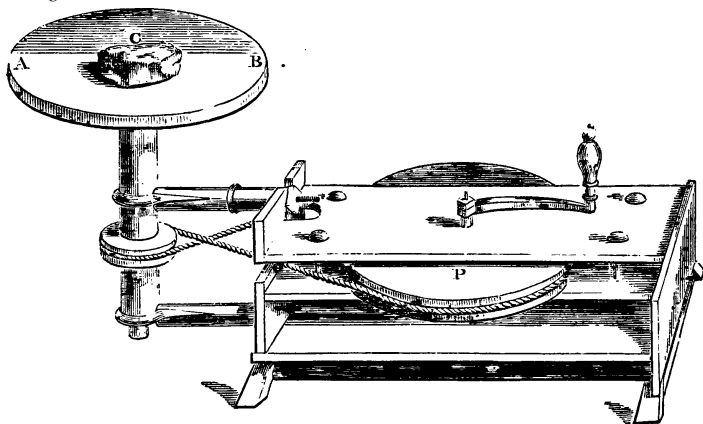

“ EXPERIMENT LXI.

“ All the apparatus of the preceding experiment remaining the same, the needle was raised, so as to be in the plane above the pole of the magnet C, whither the needle was immediately directed, being pressed downward also by the forces of the attracting pole. The needle was so placed that it might move from its meridian by the attraction of the magnet. The stone C being rapidly rotated by the wheel P, the needle continued to retain the same depression, state of rest, and direction as before ; so that this rapid rotation did not hinder the magnet from acting upon the needle.

## “EXPERIMENT LXII.

“ The same magnet C used in the two former experiments, was so attached to the table AB that both its poles, or its axis lay in the horizontal plane ACB. The needle was placed upon another table which was fixed, so as to be in the same horizontal plane with ACB. The magnet being rapidly rotated the northern point of the needle became inverted, and was directed towards the magnet; and remained in this situation immovably, as long as the magnet was revolved with the utmost rapidity; but when its motion was slackened, the needle was observed to oscillate. The effect was observed to be the same, whether the needle was placed north, east, south,, or west of the magnet; for the northern point was always attracted toward the magnet.

“ From this experiment we again learn, that a very rapid rotation of the magnet does not prevent the needle from being attracted. The northern point of the needle was directed to the magnet, because the southern pole of the magnet, against which the needle was rubbed, has in this part of the world a greater power of attraction than the northern.

## “EXPERIMENT LXIII.

“ The magnet attracts pure iron, as also that which is impregnated with force by a magnet; but it acts upon the latter at a greater distance than it does upon the former. The distances at which the action of the magnet upon impregnated iron begins to be visible, are to those of its action upon iron not impregnated, as about 5 to 2.

“ Whiston <sup>1</sup> was the first to whose sagacity we are indebted for this observation. Iron, therefore, which has been drawn over the magnet and is imbued with forces, is, as it were, in the centre of these forces which are diffused to some distance ; and the forces of the magnet and of the iron meet each other, as it were, and act upon each other in the intermediate space ;

<sup>1</sup> See his *Longitude and Latitude found by the Inclinary Needle.*—Trs.

unless we suppose that the iron which is endued with force is more mobile than the other, and, therefore, capable of being moved by smaller magnetic forces at a greater distance.

“EXPERIMENT LXIV.

“ If a magnet homogeneous in substance is covered all round with extremely fine iron filings, or with Indian dust, there will not be a point on its surface to which the attracted filings will not adhere. A greater number will cling to the corners and poles than to the sides and plane parts of the magnet. Every point, therefore, of the magnet is attractive; but not in an equal degree.

“EXPERIMENT LXV.

“ If iron filings are sprinkled thinly and equably over the plane surface of a body not very dense (not excepting even iron); and if a magnet is placed directly below the body, one of the poles being turned upwards; at first a great number of the particles of iron will be observed to unite together into the form of an oblong needle; and those will be erected perpendicularly over the surface which are directly in the region of the pole of the magnet. When the magnet is moved to the right along the length of the sustaining plane, all the filings fall to the left; when the magnet returns to the left, they are all raised and then fall to the right. The same effect is observable whichever pole of the magnet be turned upwards. After frequent motions of the magnet to and fro beneath the plane sustaining the dust, the filings arrange themselves into an oblong series.

“ Moreover, if the side of the magnet be turned toward the plane and moved to the right and left, then the filings also become erect, and fall in a direction contrary to that in which the magnet is moved; they fall, however, a little obliquely, being attracted by the poles on either side more than by the meridian of the magnet.

“ If the magnet below the plane be moved to the right and left, with one of its poles upwards, so that the filings come



into an orderly series; then, if the magnet is inverted and with the other pole upwards is moved again as before, the filings will indeed adhere, but in such a manner as to seem uncertain which way to turn or to fall; but if the motion of the magnet is repeated, they become erect, and fall in a direction contrary to that in which the magnet was moved.

“ If, however, the magnet is drawn over the iron filings, that part of the filings which lies beneath the magnet becomes erect; but it follows the motion of the magnet; so that if the magnet is moved to the right, the filings fall to the right, and the contrary. The experiment may be best performed by sprinkling the filings over thin metallic plates ; as in ancient times Lucretius, seem to have done when he thus sings :—

“ ‘ I have seen Samothracian iron rings even jump up, and at the same time filings of iron rave within brass basins, when this magnet stone had been placed under; such a strong desire the iron seems to have to fly from the stone. So great a disturbance is raised by the interposition of the brass.’ <sup>1</sup>

“ Now Gassendi<sup>2</sup> thought, that as in this experiment the particles of filings are erected and fall, so are the parts erected and arranged in the solid iron which is rubbed against the magnet; therefore, that in iron the parts lay to the left when the magnet was drawn over them to the right, and the contrary in the contrary case; just as in a corn-field the stalks lean all on one side in the direction of the wind, and then on the other when there is a contrary wind. To me, however, the parts of the solid iron appear to cohere too strongly to allow of such an arrangement by the magnetic force. But even were Gassendi’s view of the case granted, it does not enable us any the more clearly to perceive in what manner, from the arrangement of the parts of the iron, the power to attract another piece of iron would follow; nor what a mere arrangement would contribute toward giving a direction of the iron to particular quarters in the heavens ; unless we called in to our aid the hypothesis of a fluid.

<sup>1</sup> *De Rerum Natura*, lib. vi. 11. 1042-1046, translated by H. A. J. Munro.—*Trs.*

<sup>2</sup> *Animadversiones in Decimum Librum Diogenis Laertii*, vol. i. p. 373.—*Trs.*

“ The foregoing phenomena, however, are easily explained, provided we first bear in mind that small oblong fragments of needles, instead of filings, placed upon a plane, become, when the magnet is drawn along underneath them, plainly erect in a similar manner, and fall in a direction opposite to that in which the magnet is moved. Hence the filings may be considered as a collection of small but oblong fragments. Let a magnet be conceived as being directly underneath one particle. This particle will be erected perpendicularly upon the plane, and both its extremities become polar; the extremity in contact with the plane is a pole of a different name from that of the magnet which there touches the plane ; for it is only those magnetic poles which are not similar that attract each other. Now the upper extremity of the particle is a pole similar to the pole of the magnet; and because the similar poles of magnets repel each other, so are we to conceive this one also as repelled by the pole of the magnet. Let the magnet be now moved below the particle leftwards, it will then endeavour to draw along with it that extremity of the particle which is in contact with the plane; but which is prevented from following it by the roughness of the plane, and consequently remains in its former place ; while the pole of the magnet which repels the upper extremity of the particle acts upon it obliquely, and indeed toward the right; consequently, it will be driven to the right, taking an oblique position. When the magnet is moved farther on so as no longer to act upon the particle, the latter by its gravity will fall to the right. What we conceive to be the case with one particle, is the case with all; therefore, when the magnet is moved to the left below the plane, the particles placed upon it will at first stand perpendicularly, and afterwards fall to the right.

“ When, however, the magnet is drawn over the filings and the plane, every particle takes an erect position; the upper extremity of each becomes a pole, having a name different from that of the pole of the magnet which it faces. Consequently it is attracted by it and follows its motion. When the magnet,

therefore, is moved to the left over the filings, the particles fall to the left; the result being obviously the contrary of that which takes place when the magnet is drawn along beneath the particles.

“ EXPERIMENT LXVI.

“ Fig. 51. If round the magnet AB, placed upon a plane, iron filings or rather Indian dust is sprinkled to some distance ; and if the plane is then gently tapped, the dust takes a regular oblong arrangement, leaving intervals such as are presented

*Fig,*

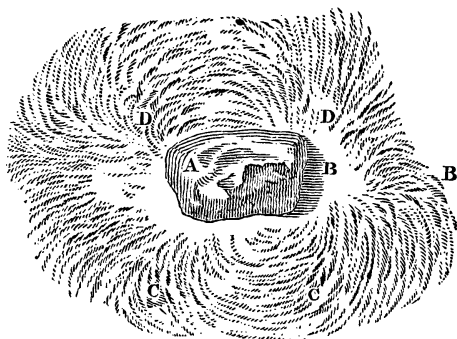

by the figure. In this arrangement two quarters, AA, BB, may be observed, exhibiting for the most part straight lines ; while others lie curved around each side of the magnet, as DD, CC, which are only portions of curves which are enlarged in proportion to their distance from the magnet. The lines, however, do not all leave an equal interval between one another; but near the magnet are more contracted and about  $\frac{1}{2}$  of a line of a Rhenish inch. The intervals are not altogether without interspersed dust, adhering in some lines, and running out irregularly to the neighbouring lines. This, however, is more the case at a greater distance from the magnet than near it. These appearances may best be seen by placing a magnet over a sheet of glass, under which lies some white paper; for there is no

smoother surface upon which iron dust or Indian dust can be disposed into a more orderly series.

“ Upon examining these lines, as arranged round the magnet, one might at first be disposed to presume that they resulted from some fluid flowing round the stone ; and which, being conveyed in between parts of the iron, disposed them into this regular order, in providing itself a channel, by removing those particles which served as obstacles to its course. On further attention, however, nothing will appear to be less true; for since the iron dust is extremely heavy and large, the fluid which would move it from its place and arrange it in order must be considerable in quantity, and move rapidly and with great force, and possess great power. Consequently it will move, propel, disperse, or arrange the dust or lightest particles of bodies, such as flour, sawdust, ivory-dust, dust of tin and copper, with greater facility than it will move extremely heavy particles of iron. Yet none of these sprinkled around the magnet are disposed into lines, or put into motion, but lie in the state of rest in which they had fallen, just as if no magnet were present. How then can we conceive of a fluid which moves larger and heavier bodies, but is unable to operate upon the lightest ? But suppose it be said that the fluid does not flow in the intervals between the lines, but through the substance of the iron particles of dust; and that they receive their arrangement in consequence of this. Yet even if this be granted, how is it, I would ask, that the fluid does not move the lightest parts of flour, which it meets and penetrates, when it moves extremely heavy particles of iron ? and secondly, how particles of iron can be arranged into lines leaving intervals between them, and not rather be arranged near one another ? These difficulties no one can easily solve, until we better understand the nature of the magnetic forces.

“ EXPERIMENT LXVII.

“ Iron filings were sprinkled over an iron block 6 inches thick, to whose lower extremity a magnet was applied, and

immediately the particles stood erect; a proof that the force of the magnet even passes through extremely thick iron.

“ After this, iron filings were sprinkled thickly over another iron block one inch thick. On this was placed the preceding block 6 inches thick, and iron filings were sprinkled over its upper part; the magnet was then applied to the lower block, and transfused its forces through the whole of this apparatus up to the filings sprinkled at the top ; and this caused them to stand erect as before. Therefore the magnetic force not only passed through the solid iron, but also through the space between, in fact, even through the disconnected dust into the solid mass.

“ **EXPERIMENT LXVIII.**

“ Let two magnets be placed near each other, so that the similar poles of both are upwards, and at the same level. On these let a sheet of glass be placed upon which iron filings are sprinkled; the latter then become arranged into the same lines and forms produced by each magnet as before ; except that in the place between the two poles there is a polar centre, or centre of forces, which is to be considered as one pole ; while at a greater distance the magnetic force is seen to be diffused around; both magnets mutually assisting each other.

“ **EXPERIMENT LXIX.**

“Fig. 52. Let two cubical magnets, with their like poles upwards, whose surfaces are plane and polished, be so joined together that the thin iron plate C may be between the two A and B. Let iron filings be sprinkled upon a tablet placed upon them; then these will become arranged into lines, represented by the figure; in which the polar placed of the strongest magnet B is clearly indicated; but over the plate C are seen scarcely any filings, and beyond this place all is in disorder.

“ This experiment differs from the former in consequence of the interposition of the iron plate C which produces all these irregularities of attraction, preventing both poles from uniting

in the middle, and making one common pole for the forces : it causes, however, the forces of each magnet to remain distinct.

Fig. 52.

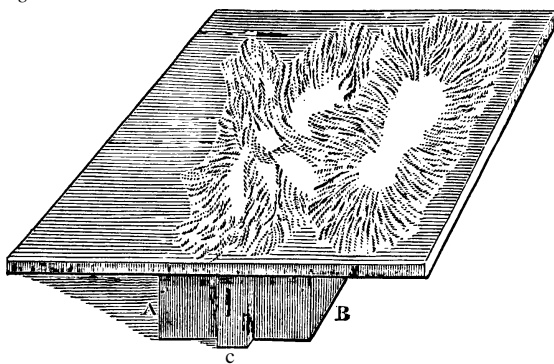

But because the magnet B is stronger than A, the more strongly it emits its forces to the sides which face it, forces which penetrating the iron fence disturb the order of the filings produced by A.

“ EXPERIMENT LXX.

Fig. 53.

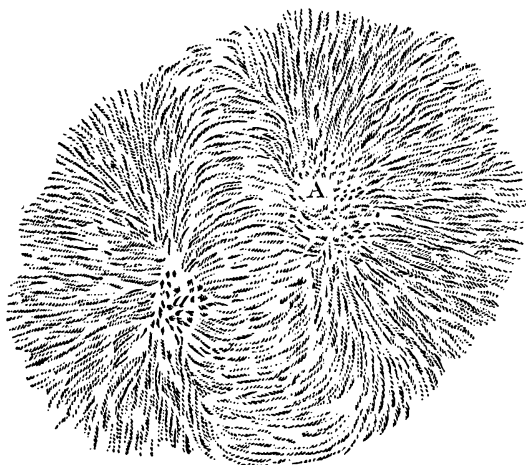

“ Let both the same magnets be placed near each other without any intervening obstacle; but so that the poles of different

name look upward. Over a little tablet placed upon them, let iron filings be sprinkled; then these, as in fig. 53, will exhibit both poles at A, *a*; in the middle between them the filings will be disposed into a curvilinear figure regularly convex ; but inasmuch as there is emitted all around a force pursuing a rectilinear direction, it will dispose the filings likewise into a right line. Between the poles A, *a*, the figure of the filings is the same as if both magnets lying in the same horizontal plane faced each other with their poles of different name; thus there is no repulsion of the filings, but an amicable attraction produced by the forces of conspiring poles.

“ EXPERIMENT LXXI.

“ If iron filings are poured into glass tubes, and closely fastened in, they are equally receptive of magnetic force as a single undivided piece of iron ; as we learn from rubbing it upon a magnet, and then examining its magnetic forces; for there is no difference between the two, except that the parts in the mass are united more closely than they are in the filings: although in filings compactly arranged the parts are pretty close together. If, however, the filings are shaken, so as to make the different parts change place, then all the magnetic force ceases; for the parts are rubbed by one another in different directions. And as iron was deprived of magnetic force when rubbed against the same pole of the magnet in a direction contrary to the previous one, so by similar contrary frictions does the force disappear from the filings.

“ EXPERIMENT LXXII.

“ Hitherto, it has been evident that a magnet attracts iron; but because iron is a very compound mass, made up of sulphur, salt, and earth, it remains for us to examine what is in the iron which is attracted; whether it is sulphur, salt, earth, or all these together.

“ If iron is heated as strongly as possible in a coal fire so as'

to emit sparks, and then be taken out of the fire, and the spherical sparks which had vitrified are collected, then neither are these attracted by the magnet, nor do they in any manner deflect the mariner's needle from its direction. Vitrification is the ultimate state to which any metal or body can be reduced ; this vitreous substance consists of earth ; but whether it possesses an admixture of anything else cannot be discovered. Consequently after the earth of the iron has been acted on by a very intense heat, it no longer possesses magnetic force, nor can it be made to receive it.

“ The scoriae, which fall from iron when hammered upon an anvil and are broad and smooth, are very strongly attracted by the magnet; and after being once attracted, they receive a force which they retain for some time. But when they are presented to a magnetic needle as soon as they are taken from the iron, they do not act upon it much, although they deflect it from its position.

“ These scorise have undergone less combustion in the fire than the vitrified globules; they are, however, deprived of their sulphur and salt; consequently, they no longer melt in the fire, nor burn ; they contain, therefore, within themselves that principle or that kind of bodies which, hitherto, we have seen attracted by the magnet; and which, in a continued strong fire, is made to fly off before the mass becomes vitrified. Consequently, that kind of body which is in iron and which is the only one attracted, does not appear to constitute any considerable portion of it; since the iron consists mostly of sulphur and of a copious matter which turns into glass. This substance, however, is very fixed; for it does not fly from the mass except by the process of vitrification; a process which is effected only by the strongest fire which art can produce.

“ If now we could extract from the iron that part which is attracted by the magnet, then would this attract and be attracted most strongly; and the nearer we approached to this substance in its purity, the more strongly attractive would be the mass we obtain. With this view I endeavoured to deprive



the iron of all the matter which is not attracted by the magnet, in the following manner. I placed iron filings at some distance from a needle 6 inches long, and gradually moved it nearer until I clearly saw the needle act upon the filings and become disturbed in its position. I then placed some filings in a small bottle which I placed in the same arc of a circle which the point of the needle described, and at a distance from it of half an inch. The point of the needle, in consequence of the attraction, adhered to the surface of the bottle. The bottle being at rest, I gently poured into it oil of vitriol, which dissolved the filings. After about two minutes the needle in some degree abandoned the bottle, returning to its former natural position. The more the filings became dissolved, the more the needle receded from the bottle. It never, however, returned exactly into its former position. The same result took place when I dissolved the iron in Glauber's spirits of nitre,<sup>1</sup> or in common *aqua fortis*; the attractive force was always diminished, but never entirely taken away. From the solution of iron I prepared vitriol of steel; which, when well dried and presented to the point of a needle 6 inches long, attracted it but little; still the attraction was visible to the eye; the needle's point, receding from its former position about a quarter of a degree as soon as the vitriol was held near. This experiment I repeated several times. At first I thought I had been led into error; as that acute observer Lemery, in *Histoire de l'Academie Royale des Sciences*, 1706, *Mem.*, p. 119, had observed that the vitriol of steel did not attract the magnet. Perhaps, however, he did not make the experiment with so long a needle as I did, but only with one of the common length; in which case the most experienced eye cannot observe any motion of attraction, a motion which is visible only when we use an extremely long needle. This force of attraction was weakened when the filings dissolved, because all the parts were removed one from another; and, being agitated simultaneously in different directions, like the filings shaken in the preceding experiment, they conse-

<sup>1</sup> See note, p. 405.—*Trs.*

quently lost their force. The solution of the iron was first effected in order that the iron might be the more easily deprived of its sulphur; for sulphur adheres most powerfully to acid spirits, and, together with these, readily flies off by the aid of fire. From the vitriol placed in a retort I extracted, by means of the fire, an acid spirit mixed with sulphur; until the matter resting at the bottom was of a red colour, commonly called the *colcothar* of vitriol. When the latter was presented to the forementioned long needle, it occasioned a motion, slight indeed, but greater than that which the vitriol alone had before produced. The acid spirit collected in a bottle and applied to the point of the needle gave rise to no symptoms of attraction; whence I conclude that the sulphur of iron is not the cause of magnetic virtue.

“ I then placed the *colcothar* on an exceedingly hot fire, having put it into an earthen crucible; and the result was a black and thin mass, in which there was no longer any sign of sulphur; as Lemery has correctly remarked. This was easily reduced to dust; when thrown into the fire it emitted no sparks, as iron filings do; and it seemed to be deprived of nearly all its salt, since it did not contract rust either in the air or in salt water. It scarcely affords a tincture; nor does it effervesce with oil of vitriol, spirit of salt, or spirit of nitre.

“ This mass, whether remaining whole or pounded to dust, is strongly attracted by the magnet and by the needle, and at a much greater distance than fresh iron filings; which clearly proves that neither sulphur nor salt in the iron is the matter giving rise to attraction; but that it is some other matter, which is attracted the more strongly in proportion as it is the more entirely deprived of sulphur and salt.

“ Hitherto, this matter cohered with solid earth, which, as I before intimated, became vitrified and possessed within itself no attractive force. It required, therefore, to be separated from this inert earth as much as possible. In this respect I followed the example of Lemery, who poured upon this matter, first reduced to powder, spirit of nitre; in this case the powder

was dissolved without any sensible effervescence ; and at its surface turned into a white dust with a somewhat oily appearance, and which for some time often retained a shining whiteness sometimes it was of a deep yellow. This dust being collected by itself, and reduced almost to dryness, was still more strongly attracted by a magnet or by a steel plate, than the mass immediately preceding. This then appears to be the body which is the sole cause of attraction in the iron; and which, when mixed with other kinds of bodies so as to constitute iron, becomes in some measure impeded in its action.

“ Perhaps it is a similar or the same body which in a magnet solely excites attraction ; and which, the purer and more abundant it is, makes the magnet the stronger. This indeed may be inferred in some measure from those magnets which in process of time are generated in the air from iron; which, when it is corroded by the air into rust, mingles its salts with earthly matter. The sulphur is mixed with salts floating through the air, and, therefore, the component principles of the iron are of their own accord separated from it; namely, earth, the magnetic matter, salt, and sulphur. When, therefore, the magnetic matter enters, together with the rain, into the pores of stones in which the iron inheres, it changes them into true magnets, such as in the course of observation we are perpetually finding; provided the iron is for a long time exposed to the air, and is fixed in stone of a spongy nature.

“ From this analysis we clearly see why steel is more endued with the magnetic force and retains it better than iron; for steel, before it is ready for use, has often to be heated and hammered ; and it is clear that in the fire it deposits a considerable portion of its sulphur or oil; so that it is never afterwards so flexible as the iron; the steel, therefore, is then set somewhat free from the heterogeneous matter adhering to it, and in proportion to its mass retains more of the matter which is magnetic, and exercises a stronger attraction. Hence also we understand how iron may be endued with greater magnetic force, in proportion as it contains within itself the greater quantity of mag-

netic matter; and experience shows that all iron has not an equal quantity of it; since one piece of iron receives from the magnet a far greater power of attraction than another.

“ If vitriol of steel be rubbed against the pole of a magnet, it acquires a greater force, attracts the needle more strongly, and displaces it more from its position, than pure vitriol.

“ Boyle examined English ochre which is iron rust, but corroded by natural acid salts and mixed with earth, in order to see whether it exhibited any magnetic force, but he detected none. When, however, he afterwards treated the ochre with the fire, and expelled the sulphurous, saline, and several other parts, the residuary iron of the mass was able to exercise attractive forces, and by them it acted upon the mariner's needle. See his observations on the magnet, in his *Philosophical Works* [abridged by P. Shaw, vol. i., p. 499].

#### “ EXPERIMENT LXXIII.

“ At the commencement of this chapter we observed that the magnet attracts with great force a certain species of sand which is of a dark colour, shining, and never liable to rust. This sand is brought from Virginia, and is separated from its foreign matter by means of the magnet. Its specific gravity as compared with common sand is as 161 to 71. I thought it worth while to ascertain whether this sand were iron or some species of iron; or whether it contained within itself no metal at all; for if the latter were the case, then it would show that the magnet operates on other bodies besides iron. Moulen tested this sand in a variety of ways, and gave an account of the success of his experiments in the *Philosophical Transactions*, vol. xvii. p. 624. To these I have added other experiments which I thought would lead to a better understanding of the subject.

“1. This sand, if submitted to the fire and calcined, is after calcination more vehemently attracted by the magnet than before.

“ 2'. The calcined, sand was mixed with charcoal reduced to powder, and placed in a furnace for an hour. It did not turn into *regulus*,<sup>1</sup> but was attracted by the magnet with a still—stronger force than before.

“ The fire, therefore, only separates from the dust something which has a little impeded the attraction, but does not volatilise the matter which is attracted ; although, as will be subsequently evident, it is capable of flying off.

“ 3. The sand was mixed with fixed nitre, and was placed in a smelting furnace for an hour ; it did not change, however, into *regulus*. The rest of the mass was not attracted by the magnet, with the exception of a thin crust which adhered to the coal thrown into the crucible.

“ 4. After this it was mixed with nitre, and coal pounded to powder; but when, exposed for an hour to the action of a smelting furnace, it did not change into *regulus*. The mass thus produced was not attracted by the magnet, with the exception of those parts which adhered to the coal.

“ 5. Another part of the sand was mixed with nitre and flowers of sulphur; after having been for some time in the furnace it did not furnish any *regulus*.

“ It is, therefore, evident that nitre volatilises that which in the sand is attracted by the magnet. It is in consequence of experiencing in itself the action of nitre that it no longer experiences the action of the magnet.

“ 6. From the following process, however, it is evident that what is attracted by the magnet may be volatilised.

“ Three drams of Indian sand were mixed with 3 drams of ammoniacal salt, and exposed in an open crucible to a moderate fire, by which the ammoniacal salt was nevertheless volatilised and expelled: the entire residuum weighed 2 drams and 23 grains, and, therefore, the weight of sand that was lost was 37 grains; supposing that no salt remained in the sand. In the residue the grains were larger than before, and of a beautiful

<sup>1</sup> The metalline part of minerals, which remains in the bottom of a crucible, after the separation of the scoriae. *James' Medicinal Dictionary.—Trs.*

cinnabar colour. All the other parts lost their former blackness and tended toward an obscure red. Over these the magnet was placed and drawn, in fact, it was even applied to them, but was scarcely able to attract anything; still there was a slight attraction. The residue was washed and cleansed with water, and dried ; but it was not attracted by the magnet more strongly than before ; a clear proof that whatever was attracted by the magnet had escaped and disappeared from the sand together with the ammoniacal salt.

“ This substance, however, is not very volatile, nor does it ascend with the lightest parts of the ammoniacal salt; although with these there ascend from the sand certain parts of an orange colour, as will be evident from the following process.

“7. Three drams of sand were mixed with 3 drams of ammoniacal salt, which were enclosed in a bottle and placed in a sand-bath for three hours ; at which period nearly all the salt was sublimated, adhering to the sides and arch of the flask, and mixed with parts of the sand of an orange colour. The matter left at the bottom varied from deep yellow to black; and on being exposed for some time to the magnet, it was nevertheless but little attracted. The mass, when dissolved in water, afforded a thick tincture of a rusty colour ; leaving dust formed of rather large particles at the bottom. The solution was attended with considerable effervescence. The tincture when dried was not attracted by the magnet. The dust which had subsided consisted of several large fragments which were hard, compact, of a beautiful red colour, and which, when dried, were powerfully attracted by the magnet. They were not yet volatilised by the salt, and, therefore, retained their attractive force ; so that the ammoniacal salt did not immediately carry it off into the air, although it was now attacked with greater force.

“ From the foregoing operations, moreover, it is clear that this sand does not change into *regulus*. We therefore conclude that it has little or no metal within it, unless there be some portion of sulphur so firmly adhering to it that it cannot be absorbed by any force either of fire or of salts, and which prevents it

from being reduced to a state of fluidity, and from turning into *regulus*. Is the presence of metal, however, required in a body, in order that the magnet should act upon it ? Surely not.<sup>^</sup> There are other bodies in which it has not been demonstrated that there is any iron, as I have above remarked, and which are nevertheless acted upon by the magnet. It is not altogether improbable, \_that in this sand neither iron, nor any other metal is contained; for it does not effervesce with spirit of sea salt, nor with the strongest spirit of nitre, nor with this diluted with water, nor with simple nor with double *aqua fortis*, nor with *aqua regia*, nor with strong oil of vitriol, nor with this diluted with water, nor even if the sand be calcined or otherwise; nor, whether cold or hot, does it effervesce with these acid spirits, with which nevertheless it is known that all iron strongly effervesces. Can we, therefore, entertain the slightest suspicion that in this sand any iron is latent ?

“ 8. Three drams of this sand were mixed with 9 drams of red-lead ; these were put into a crucible and exposed to a strong fire in a blast furnace for three hours. These changed into a firm, exceedingly hard, and very spongy mass of an iron colour, of an uneven surface; in which several portions of lead that were collected into globules firmly adhered to the other matter. Not the least sign was visible of any vitrification, the production of which was the object of the experiment. The result was rather that the red-lead returned into lead; for the substance, which by the aid of a knife might here and there be separated from the other matter, was pure lead. The other and harder portion of the mass, when pounded to dust, was attracted by the magnet quite as powerfully as the Indian sand; the dust, however, was less resplendent, and was not of so black a colour; so that the lead could not expel the attractive forces from the sand. But since red-lead with common sand or quartz passes into a vitrified state, it is manifest that this Virginian sand is not an earth easily penetrated or soluble by this metal; which, when heated, commonly passes through all other bodies. That, nevertheless, it is not a simple substance, we learn from the influence exercised

upon it by ammoniacal salt and nitre. Of what more simple parts it is compounded I have not yet been able to find.

“ THE METHOD OF ARMING MAGNETS.

“ The magnet, when taken from the mine, is generally incapable of lifting or carrying any great quantity of iron; and, therefore, it is provided with an armature, by the aid of which it is enabled to carry a much greater weight of iron than it otherwise would; for this collects, directs, and condenses the forces which otherwise would be dissipated; and directs those of the two poles, so that they shall act upon the same mass of iron, and attract it simultaneously. Of the various methods of arming the magnet, I have selected the best hitherto known; although it would be premature to affirm that it is the best possible.

“ Fig. 51 (p. 451). Let us imagine that we have here before us a shapeless magnetic mass, such as is taken out of mines; which has to be so armed as to make it raise and carry a considerable weight of iron. Let it be placed on a table; let iron filings be sprinkled round it; and let its position be shifted until it indicates two quarters, the one opposite to the other, and arranges the filings into regular lines. These two quarters will be the poles of the magnet; which will be determined with perfect accuracy if we place upon them a short and slender needle; upon the poles it stands perpendicularly, but is elsewhere obliquely inflected and attracted by the other sides of the magnet.

“ 2. These two places which are found above the side on which it is made to turn, or above the plane of the rough stone, should now be smoothed and made even, so as to present surfaces parallel to one another and perpendicular to the direction of the needle placed upon them. These surfaces form the basis of the entire process ; for, when these are duly prepared, the magnet is susceptible of any beautiful form we may desire to give it, whether cubical, with parallel sides, or of any other form; for all the magnetic virtue is to be expected from the polar parts,



and almost entirely depends upon them. We are here first to observe, that the magnet must never be shortened after its polar places have been well smoothed; because the shortening—always makes it lose some of its force. The other sides, however, round its axis may be cut without detriment, as Le Lorraine de Vallemont<sup>1</sup> and many others have rightly observed.

“3. In the next place let there be provided several pieces of the softest iron, having no pointed parts, and of the form represented in fig. 54. Let ABCD be the thinner part having the same length and breadth as the entire polar side of the magnet to be armed. Let it have the thicker part EF bent at right angles, and rounded off underneath or terminating in a prominence which is commonly called the *pes armatures*.

It must be noted, that in the formation of this foot by the maker, BE must be a bent part of the iron AB, and that the grain of the iron ABE must be continuous; for those who are experienced in the art of making magnets have observed that from the foot of the armature made in the manner we have mentioned, the magnet is capable of raising a heavier weight. I have intimated that these bodies ought to be formed of the softest iron, and not of steel, as some have wrongly asserted; for magnets carry much more weight when the armature is made of iron than when it is made of steel.

Fig. 54.



“ 4. But what is the thickness required for the iron ABCD ? This question is very difficult to determine *a priori*. Let plates of different thickness and length AB be first drawn over the pole of the magnet, and let it be ascertained which is the one most impregnated with force. According to experiment xxxi. the thickness of this plate must be the same as is required in ABCD. It is customary, however, to ascertain by successive trials from what armature most iron may be carried; for example, pieces of iron A, B, C, D, E, F, are made of different thickness; with

<sup>1</sup> *Description de VAimant*. Paris, 1692.—Trs.

these the magnet is armed ; and those are selected which support the greatest weight. Others sprinkle filings over the plate AB applied to the magnet. If these are strongly attracted and are made to stand very erect, they infer that AB is too thin; if attracted slightly or not at all, they say that AB is too thick; and that it requires to be made thinner until some of the filings become attracted.

“ Let two iron bodies, of the same kind and nicely polished

*Fig. 55.*

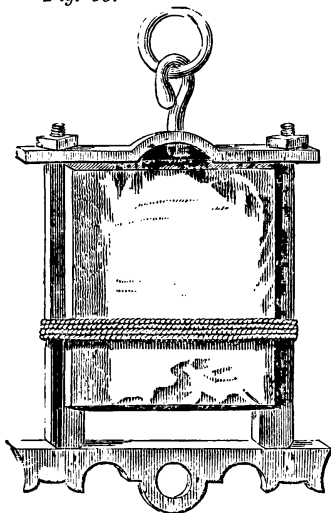

and smoothed, be applied to the magnet; one to each polar side. Let the foot BE also be in exact contact with the lower part of the magnet. Let both be closely fastened to the magnet, which, thus prepared, is said to be armed; as in fig. 55. By this method nearly all the force of the magnet, proceeding straight from the poles, enters into the armature and is directed to the foot EF; which, being a little rounded off underneath, condenses the force into a narrower space, in which it lies, as it were, con-

centrated, and from which, therefore, the greatest weight will be carried.

“ Another form of armature is described by Gassendi and by Cabseus in his *Philosophia Magnetica*, lib. iv. cap. xliv. p. 408; which is produced by boring the magnet along its axis, and passing through it a steel rod nicely fitting into the hole. This rod will from its extremities exercise considerable power. Still I would not advise any one to perforate a good magnet in this manner; because a great portion of the magnetic virtue is drilled out, and a weight can be carried only at one extremity of the rod that passes through; for in this case the two poles do

not assist each other as they do in the case which we have before described.

“ In the magnet we find various anomalies, which no one will be able easily to explain so long as we do not know what constitutes the magnetic force. The following are some, which, according to Hartsoeker,<sup>1</sup> were observed by Butterfield. There are some magnets which appear to act better when unarmed than when armed ; for when armed they disappoint expectation. Again, there are some which when unarmed appear to be extremely feeble; while those which are armed possess considerable virtue. May we presume then that the force of some magnets passes through the iron easily, while that of others passes with difficulty ? or that it depends upon the different nature of the iron ? This subject has not yet been sufficiently attended to, and consequently with regard to it we cannot arrive at any certain conclusion.

“ EXPERIMENT LXXIV.

“ A magnet, when armed in the manner we have described, attracts and sustains iron of much greater weight when applied to its feet, than when unarmed it raises at each pole. I have a magnet which unarmed sustains from each pole about 5 ounces of iron, and, therefore, would sustain from both together only 10 ounces; while the same magnet when armed lifts 7 pounds of iron.

“ As a confirmation of my observations by the testimony of others, I may remark that Mersenne mentions that he saw a magnet weighing 3 pounds, which unarmed raised only half an ounce, but when armed carried 10 pounds.<sup>2</sup>

“ Lana Terzi, in *Magisterium Natures et Artis*, Parmae, 1692, vol. iii. lib. iii. cap. i. prop. xv. p. 216, says, that he had a magnet, which when armed would lift about 864 grains, but when unarmed only 84 grains ; and he mentions that there was a magnet at Rome which when unarmed lifted scarcely a dram,

<sup>1</sup> *Bclaircissement sur les Conjectures Physiques*, 1710.—Trs.

<sup>2</sup> *Ars Navigandi super et sub aquis*. Parisiis, 1644, p. 250.—Trs.

but when armed lifted 5 ounces. From these observations it is evident that a greater weight was carried by the armature than by the naked magnet; but because we can scarcely think that these magnets were armed in one and the same manner, and with the greatest caution, so it cannot be said that the forces acquired in lifting the iron were either in the same, or in a different proportion.

“EXPERIMENT LXXV.

“If a magnet is able to support from one of its poles a given number of iron rings freely hanging from it, and if one of them is so suspended as to touch simultaneously both poles of the magnet, then this one only can be sustained by the magnet, while all the others which are applied to it fall.

“At first sight we might have thought that the united force would be stronger; for since one pole raises several rings, it might be inferred that two poles would raise more ; especially since a much greater weight of iron can be suspended from both poles than from one. But we find the contrary to be the case. The reason of this incapacity, therefore, will depend on the annular figure of the iron itself, which causes the force issuing from one pole of the magnet to destroy that which proceeds from the other, after they have met each other in a contrary direction, so that no more can be carried by the first ring.

“EXPERIMENT LXXVI.

“If an iron plate is rubbed against the foot of an armed magnet, it is imbued with a greater power of attraction than if it were rubbed against the same pole of the magnet unarmed.

“This has been controverted by some who maintain that the same force is communicated by an unarmed as by an armed magnet. I cannot agree, however, in this opinion, contrary as it is to experience. Indeed, does not reason itself contend in our favour ? For since the magnetic force is concentrated in the foot of the armature, so that much more iron is carried by it than can be by the magnet itself, does it not follow that so

much the more force will pass into the plate when rubbed ? for this is commonly the case with a stronger magnet.

“ EXPERIMENT LXXVII.

“If an iron plate adheres to both feet of the armature, and if there is in the same plane with the armature and the plate, a mariner's needle distant from the magnet and lying in a plane between the two feet and at right angles to the line joining them, the needle will not be moved by the magnet at so great a distance as if the magnet were unarmed, or the armature did not carry the plate.

“ This is the case because the force of the magnet acts upon the plate applied to the feet; and, therefore, does not become extended to as great a length as it would be if there were no iron plate.

“ EXPERIMENT LXXVIII.

“ If iron is rubbed longitudinally and simultaneously upon both feet of the armature, it does not acquire so great a force of attraction as if rubbed only upon one foot.

“ As iron acquires from each pole contrary forces of direction, which destroy each other, there remains only a smaller quantity of these forces in the iron. Therefore, in order that the iron may be imbued with any considerable force, it must be rubbed only upon one pole or foot of the magnet.

“ EXPERIMENT LXXIX.

“ The attractive force of different armed magnets in raising an iron weight is, other things being equal, in the duplicate ratio of the diameters, or in the ratio of the area of the surfaces.

“ Whiston in his *Longitude and Latitude found by the Inclinator Needle*, pp. 11,12, mentions this as the proportion found by Lord Paisley;<sup>1</sup> for since the force issues from the surface of the magnet, the larger the surface occupied by the armature the greater the quantity of forces it receives from the magnet, and

<sup>1</sup> James Hamilton, Lord Paisley, succeeded his father, in 1734, as seventh Earl of Abercorn. He was the author of *Calculations and Tables relating to the Attractive Virtue of Loadstones*, 1729.—Trs.

the greater weight of iron will it carry. Thus we see how greatly the magnetic force differs from gravity, which is in the ratio of the density of bodies, or in the triplicate ratio of their diameters. It is evident, therefore, that the force of the magnet cannot depend upon that law of nature by which, in the case of two bodies, the one attracts the other; for then the force would be in the ratio<sup>A</sup>of the "quantity of matter ; that is to say, it would be as the gravity; whereas, on the contrary, it is now seen to be only proportioned to the area of bodies.

“EXPERIMENT LXXX.

“ A uniform force of two good unarmed magnets, not sensibly unequal in power, and similar in shape and position, but of unequal magnitude, is sometimes a little greater or less than in the ratio of their diameters.

“ Whiston also remarks that he had learned this from various experiments ; he confesses, however, that there is great difficulty in determining whether different magnets, or different parts of the same magnet, are equally good; because it is commonly impossible to succeed with exactness in the experiment.

“ A magnet is generally endowed with two poles, which are places of some breadth, and not mathematical points like the poles of the earth, or of the heavens. We have mentioned above, that the greatest attractive force of the magnet is exercised by these poles. These, consequently, are easily discovered by applying iron to the magnet on different sides, and ascertaining the places to which it is most strongly attracted. They are most easily discovered, however, by sprinkling iron filings, or by taking round it a mariner's needle placed upon a moveable pin; in whicVcase the needle flies toward the poles with the greatest impetuosity.

“ Sometimes the two poles are directly opposite to each other in a right line ; sometimes also in a curved one. Moreover, we do not in all magnets find necessarily only two poles; for

I have myself seen, and other authors also have observed, magnets in which there are three poles, as Fournier also has shown<sup>1</sup>; as also magnets which have manifestly<sup>^</sup> four poles. Puget in his *Treatise on*

Fig. 56.

*Magnetic Experiments*, written in French,<sup>2</sup> makes mention of a spherical magnet (fig. 56) ABCD, standing upon an ivory foot, whose pole A attracts the point of a mariner's needle, and by the opposite part C is also attracted; a proof that A and C are similar poles. By B the opposite

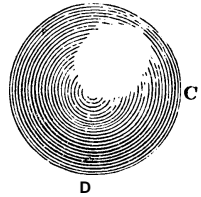

end of the same needle was attracted, which also the opposite point D equally attracted. A celebrated maker of mariner's needles at Rotterdam, of the name

Fig. 57.<sup>3</sup>

of Dykgraaf, possesses a magnet, which he lent me for examination, of a cubical form, as represented in fig. 57, on whose front side NZ are two poles, one of which N is the north, and the other Z the south. The side NZ opposite to the former has also two poles; one of which

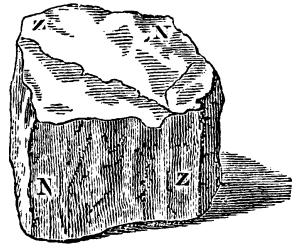

N is the north, and the other Z the south. In the possession of the same maker there is another magnet of an oblong form (fig. 58) in which were first

Fig. 58.

observable three poles ; one B the north, and two south poles M, M ; but when the magnet was divided by the section FK the fragment BMKF was observed to have four poles ; two north B, B, and two south M, M. I have examined another

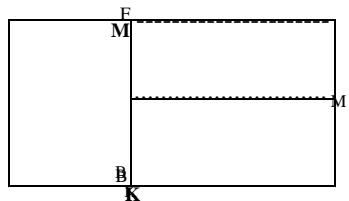

<sup>1</sup> *Hydrographie*. Paris, 1667, p. 405—Trs.

<sup>2</sup> *Lettres Merites d un Philosophe sur les Effets de VAimant*. Lyons, 1702.—Trs.

<sup>3</sup> The letters NZ are supposed to be on the opposite side as mentioned, and not on the upper surface as they appear.—Trs.

magnet which, in almost every point of its surface, seemed endowed with a pole, and exercised in every direction an equal force of attraction; magnets of this kind, however, are anomalies. Only a small number of magnets have their two poles directly opposite one to another. On regular magnets I shall again have to treat in the sequel.

“EXPERIMENT LXXXI.

“ If a magnet is placed on a small wooden float which floats upon water in a large vessel, with its axis parallel to the horizon, it will turn itself until its poles face distinct quarters of the heavens, one of which, in this region, will be toward the north, the other toward the south.

“ Those persons speak but incorrectly, and have made but inaccurate observations, who affirm that the magnet turns exactly to the north and south ; for in the sequel it will be shown that there are only few places on the surface of the earth in which the magnet points exactly in these directions; since there are only three meridians of the kind hitherto known. It is sufficient for our present experiment simply to mention this circumstance : in the sequel we shall speak of it more at large.

“ It is not requisite that the magnet, whose direction we have to examine, should be supported by a float; for the same result occurs if the magnet, with its axis parallel to the horizon, is suspended from a fine silken thread not twisted but woven. Nor is any difference observable whether the magnet be great or small, whole or divided into parts; for all its particles are urged in the same direction.

“Definition. The pole of the magnet which always turns toward the north is called the north pole, and the one which turns toward the south is called the south pole.

“ *Scholium.* It is uncertain when it was discovered that the magnet, as also iron drawn over it, points toward the north and south quarters; as also when it began to come into use among mariners, and when the needle was brought into the present form of the compass, and adapted to maritime uses.



It is probable that at first some one accidentally found that one pole of a needle, placed on a little float and swimming in water, was constantly directed toward the north and the other toward the south. Next it was found that iron rubbed upon the magnet and placed in a similar float was turned in the same direction ; that afterwards the iron was placed on the point of a pin so as to be able to move more freely and rapidly; that next the question arose whether it would be of any use to mariners, so that when the sky was covered with clouds and neither sun nor stars were to be seen, mariners might be able to distinguish the north and south poles, and thus direct their course safely over the seas ; and that the defectiveness of the plan of placing the needle solely upon a pin, observable on any concussion of the vessel, gave rise to the mariner's compass, and thus that the invention arrived by degrees at its present state of perfection. This at least is the ingenious conjecture of Dr Wallis in the *Philosophical Transactions*, vol. xxiii. p. 1106.

“ The use of the compass at sea seems to have been first known to those inhabitants of Gaul who inhabited the shores of the Mediterranean; but what individual was the first on board ship to begin to use the compass, and when, is unknown. The needle, however, was known before the year 1180 a.d. ; because there then lived and wrote a Gallic poet of the name of Guyot de Provins, who called the compass a *marinette*, and an unerring piece of workmanship ; his verses are as follow :

Icelie estoile ne se muet,  
Un art font qui inentir ne puet  
Par vertu de la Marinette,  
Une pierre laide & noirette  
Ou li fer volontiers se joint.<sup>1</sup>

“ These verses may be found in Fauchet's *Recueil de VOrigine de Langue et Poesie Francoise, Ry me et Romans*, Paris, 1581,

<sup>1</sup> This same (the pole) star does not move,  
And they (the mariners) have an art which cannot deceive,  
By virtue of the compass—  
An ugly brownish stone,  
To which iron adheres of its own accord.

—From *La Bible Guyot*, a MS. in the Royal Library. Paris.

p. 91, or in Perrault's *Parcdele des Anciens et des Modernes*, vol. iv. Paris, 1696, p. 90; and are referred to in Gassendi's *Animadversiones in Decimum Librum Diogenis Laertii*, Lugduni, 1649, vol. i. p. 364, who also in demonstrating it to be an invention of the Gauls, mentions that the mariner's needle is adorned with the lily, which is the insignia of the kingdom of the Gauls. This invention crept along the shores of the Mediterranean, and thus came to Venice; where it was first brought into notice by Paul, a Venetian, to whom, therefore, is ascribed the credit of the discovery in the year 1260. It was also taken to the city Amalphis, in the kingdom of Naples, where it was first brought into use by Flavio Gioja, about the year 1300, whence the verse,

Prima dedit nautis usum magnetis Amalphis?

To those two were assigned the credit of the invention by their respective countrymen; undoubtedly only because they were the first in their own country who used the compass, which for a considerable time previously had been known to the Gauls.

#### <sup>14</sup> EXPERIMENT LXXXII.

“ If a magnet, placed in a small wooden float to prevent its sinking, has its axis perpendicular to the horizon, and is supported

59

in a large vessel; it will always turn the same end northward and the other southward.

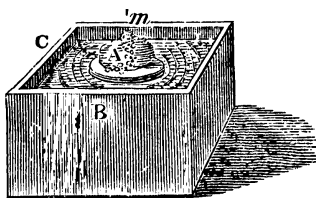

“Fig. 59. Let the magnet A supported by a float in a vessel full of water CB face the zenith with its south pole *m*. Over the middle of the vessel let there be suspended the iron needle E upon which the magnet acts, in order

to keep it in the middle of the vessel with greater facility. Let the part of the magnet be noted which looks to the north when

<sup>1</sup> *Amalfi first gave to sailors the use of the magnet.* This line is attributed to Antonio Beccadelli, otherwise known as *Antonius Panormitanus*, i.e. Antony of Palermo.—*Trs.*

the magnet is left to itself; then let it turn again, and, when left to itself, it will present as before the same side to the north, as Grandamicus first observed.<sup>1</sup>

“ EXPERIMENT LXXXIII.

“ Fig. 60. Let AC DK be a magnet whose two poles are A, D, and consequently whose axis is AD. Let the magnet be divided at CK by a section perpendicular to the axis ; then will the pole of one segment A, which before was the southern, be still southern; and B will be the northern : also the part *a* of the other segment, which adhered to the north pole B, will be a south pole, and the part D a north pole as before.

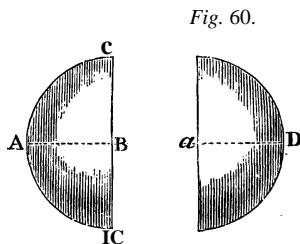

“ This experiment has been controverted, and requires, therefore, another and more accurate examination. Any one who is not in possession of magnets of little value, or who is not clever in the art of separating them, may perform the same experiment with iron wire which has first been drawn over the magnet; for, when divided into parts, it will exhibit the same phenomena. Porta in his *Magia Naturalis*,<sup>2</sup> Lugduni Batavorum, 1651, p. 286, and, afterwards, Ridley in his *Short Treatise of Magneticall Bodies and Motions*, London, 1713, chap. ix. p. 33, affirm the contrary, maintaining that after the section the south pole A will be changed into the north. Whether this really occurred to them I know not, but I doubt it; for the contrary happened to me, and I find on my side Gilbert (*De Magnete*, lib. ii. cap. v.), as also Barlow in his *Magneticall Advertisements*, chap. ii. p. 11. Nevertheless neither Del Porta nor Ridley can be accused of stating an untruth; for perhaps when they made this experiment they split the magnet with a wedge, and by subjecting it to considerable violence,

<sup>1</sup> *Nova Bemonstratio Immobilitatis Terra, petita ex Virtute Magnetica*. Flexise, 1645, pp. 122-123.—*Trs.*

<sup>2</sup> Porta's *Magia Naturalis* was first published in 1558.—*Trs.*

changed the directive force of the magnet. For I have observed, that when with a file I have slowly but completely cut the iron into parts, in all the segments the directive force remained the same; but when, with a file, I had separated the parts of the wire only to the middle, and broke off the rest by twisting it, or when I had cut it with a chisel and hammer, the south pole changed into a semi-north pole and sometimes entirely into a north pole; whence it happened that a segment of the same kind had two north poles at its extremities.

“ EXPERIMENT LXXXIV.

“ Fig. 61. Let CD be the axis of the round magnet ABEF, C the south pole, and D the north pole. Let the magnet be divided by a section through the axis; then the segment

Fig. 61.

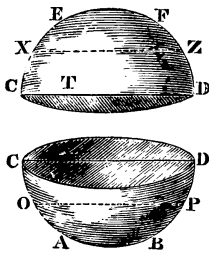

COABPD will have its south pole in O, and its north pole in P; the segment CXEFZD will have its south pole in X and its north in Z.

“ These segments, therefore, retain the same poles with which they were before endowed; the only change is in the axis, which becomes XZ and OP passing through the middle of every segment. The same obtains, in every section parallel to the axis. It is, therefore, evident that the whole of the side EXCCOA is polar, and constructed in the same manner. But it might appear as if certain quarters such as C and D were the only poles, when nevertheless every point in the side ACE or BDF is polar ; but in the entire magnet the poles C and D were concourses of forces, or a centre of poles on each side.

“ EXPERIMENT LXXXV.

“ Fig. 62. Of the two magnets AB, *ab*, let the south poles be A, *a*, and the north poles B, *b* ; these, if placed in the same horizontal plane, can approach each other; the north pole

of one will attract and join to itself the south pole of the other ; therefore (fig. 63) the magnet AB if held over the other *ab*,

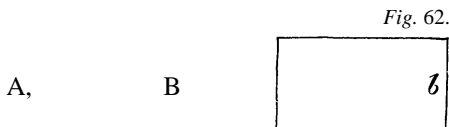

\*="~

will, if each be able to turn freely, turn in such a manner that the south pole *a* will be directly under the north pole B, and the north pole *b* under the south pole A.

“Nor let this circumstance occasion surprise ; for it will be evident to any one who contemplates the magnet, which before was a whole but is now divided into parts, that the parts of the whole were put together in this very order. For if the two magnets AB, *ab*, had before constituted one mass, would not the part *a* have adhered to the part B ; and these two parts

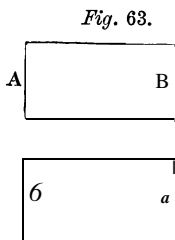

have attracted each other ? When, therefore, they are separate, as in the present case, will they not do the same ? Thus will the poles of different name conjoin themselves together; while the similar poles, such as the two north or two south, will shun each other; for these have never naturally cohered in the magnet.

“EXPERIMENT LXXXVI.

“ Fig. 64. Let A, *a*, be two prismatic magnets; the south poles of which are MM. Let the north poles BB be so made that one of them terminates in a point. Let both magnets be joined together so as to constitute one brick - shaped mass. This mass will have two poles, and an axis passing through its middle.

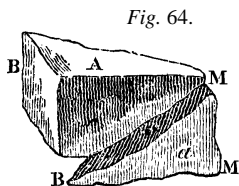

“ From this experiment it is again evident, that the polar

quarter of the magnet is only a collection of poles. Also that the pole is the centre of their forces. So that the whole force of the pole B of the lower magnet approaches toward the pole of the upper, which also approaches toward that of the lower; and thus both poles coalesce into one situated in an intermediate place of the side BB.

“EXPERIMENT LXXXVII.

“ Let a homogeneous spherical magnet be placed upon mercury, so as to float freely, with its axis parallel to the horizon. If left to itself it will move from its horizontal position ; inclining its north pole, in this region, downward, and raising the south pole. This inclination varies every year in the same region, and in the same year in different regions ; as will be more clearly seen in the sequel, when treating of the experiments made with the mariner’s needle.

“EXPERIMENT LXXXVIII.

“ If a long magnet be placed in a fire for a short time, so as just to acquire a red heat; then if it be placed perpendicularly to the horizon and allowed to cool, its lower extremity will become the north pole. We shall have occasion to observe in chap, v., that the same occurs in the case of iron when left to cool in the same position.

“EXPERIMENT LXXXIX.

“ If a long magnet be heated, and placed perpendicularly upon the north pole of a stronger magnet, and be allowed to cool in this position; the heated magnet will acquire considerable virtue from the stronger, and its lower pole will now become, not north but south ; and will strongly attract the north pole of the mariner’s needle. If a magnet, before it is placed in the fire, is feeble; then, if while it is still hot it is placed upon a stronger one, it will become endowed with considerable strength,

and greater than it had before. The celebrated Boyle observes,<sup>1</sup> that he had examined a magnet which when cold scarcely lifted a fragment of a needle ; but after being made red hot, and placed — upon a strong magnet on which it remained till it was cool, it then carried considerably more iron. If a weak magnet, when cold, be placed upon a stronger, it acquires an increase of its forces ; but not so soon, or in so great a degree, as if the magnet when heated were placed upon another.

“ The fire by rarefying the magnet separates all the parts from one another, and makes them less cohesive, for it renders the hardest metals fluid ; and, therefore, a strong magnet placed beneath another heated one, consisting of parts easily displaceable and placed in a different order, so agitates, arranges, and directs the parts of the latter by penetrating them with its virtue, that they afterwards possess a much greater power of attraction. A •cold magnet, however, does not consist of parts so easily moveable, and capable of being disposed in a different order. Therefore the parts of a cold magnet placed upon a more powerful one, are not so easily changed or arranged in a different manner; nor can they be impregnated with so great a degree of force.

“ By adopting this method we are enabled first to change the poles of magnets; and secondly, to impart more strength to weak magnets.

“ The foregoing are the primary phenomena which magnets •exhibit in regard to the direction of their forces. Others I purposely omit, both because they appear to be of little moment, and because I do not wish to be tedious, desiring rather to pass on to an investigation into the direction observed by iron, which will supply us with more accurate observations. I enter into no explanation of the manner in which the phenomena happen ; preferring as I do to add the theory of Halley,<sup>2</sup> with a few notes ; and if these be understood, we shall see what opinions ought to be held on the cause of the direction of magnets.

<sup>1</sup> *Experimenta et Observations Physicce*. London, 1691, p. 10.—Trs.

<sup>2</sup> *Theory of the Variation of the Magnetical Compass*. London, 1683.—Trs.

“ Definition. We shall call by the name of needle, the magnetic or mariner’s needle. Fig. 65. If a steel needle EF be furnished in its middle with a

Fig- 65.

E

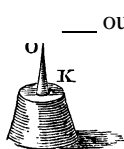

\_\_\_ out underneath and placed upon

the copper pin K, so as to turn round upon it freely ; then the point E we shall call the head of the needle, and F the tail.

#### “ EXPERIMENT XC.

“ If the end of a piece of iron wire is placed upon the pole of a magnet, not so as to rub it, but only to apply itself and then to pull the magnet, the wire will throughout its whole length exhibit certain magnetic polar points in different places, which are called consecutive points, because they attract alternately the north and south pole of a needle, whose point of suspension is moved slowly along the wire at the distance of half an inch.

“ I took a new needle, which I had just before heated, and which was not yet impregnated with magnetic forces. This needle was 12| inches long ; and I used it in place of the wire or iron rod. When balanced upon a pin, it was extremely mobile and was disturbed by very small magnetic forces. I held over this, and drew along its length, the northern end of a needle which had been rubbed against a magnet; and I then observed six consecutive points. The end of the new needle was attracted ; while a place distant thence 1| inches was repelled, and extended for 6 inches. There was yet another attracting place and another repelling ; the next place to this was attracted, and lastly again the other extremity was repelled. But when the south end was drawn along the length of the new needle, there were observed only three consecutive points, and in places different from those in which they were before observed. For the extremity of the new needle was repelled; this repulsion continued along a space of



1| inches ; then followed a slight attraction, extending almost to the extremity; and after this a very powerful attraction distinct from the former. These phenomena were all much more clearly seen after the end of the new needle had once been applied to the pole of the magnet.

“ The first to describe this experiment were the celebrated Desaguliers, and Taylor, in the *Philosophical Transactions*, vol. xxxi. p. 204. The latter took five common steel needles 2 inches long (the ends of which had before been applied to. the magnet), and placed them upon still water; he then moved the head of a magnetic needle along their whole length, yet so as not to touch them, and then the south or north pole of this needlejvas attracted by the points marked in fig. 66, and indi-

Fig. 66.

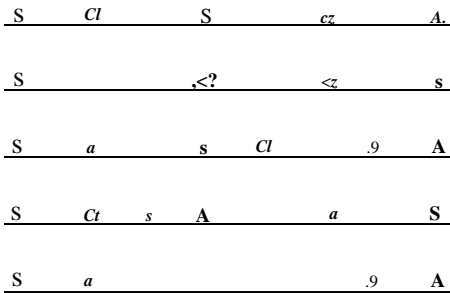

-cated by the letters A and S. In the first needle five poles were observed; and also in the second; between these there was only this difference, that both the extremities of one attracted the north pole. In the third were 6 poles, in the fourth 7, in the fifth 4.

“Do not these phenomena depend on spines of iron abounding in a greater or less number, and intersecting as it were the iron, so as to divide it into various fragments, at whose different extremities are different attracting poles, stronger or weaker according to the structure and situation of the spines ? This indeed is probable ; for it is evident that in all iron and steel there are spines which are indeed iron, but harder and different

from the rest, and sometimes as distinct from it as a knot in wood from the rest of the grain. These spines being placed in no order, the consecutive points do not observe equal or proportional distances from them.

“ EXPERIMENT XCI.

“ 1. The middle of a new needle 12| inches long was placed upon the south pole of a magnet: when drawn away its head was directed to the north, and its tail to the south. 2. The north part of this needle, placed at its middle over the south pole of the magnet, was then drawn from the middle toward its northern end, for a length of about two inches ; the needle was then placed upon a pin; but its northern end observed scarcely any direction, the needle being sluggish ; still it pointed to the north, and when the north point of another needle was drawn along its length, only two poles were observed ; one of which being very sluggish was the north, at a distance of two-inches from which the entire length of the needle was attracted by the north point of this other needle ; its south point, however, was not sluggish, but most strongly attracted. 3. The middle of the same needle was next placed on the south pole of the magnet,, over which the north part of the needle was drawn to the place where a consecutive point had just before been observed, but not to the end. In this case the direction of the needle was the same as before, but it was observed to move much more readily, and to have no more than two poles, one at each end; the force of each terminating in the middle of the needle.

“4. All the phenomena were the same when the middle of this needle was placed upon the south pole of the magnet, and the north part of the needle was drawn over it to its end.

“ 5. The middle of the needle was again placed on the south pole of the magnet, and the south part of it was drawn for some distance toward the end from the middle. The needle now began to grow very sluggish, observing scarcely any given direction, and declining for the most part from the magnetic meridian. The point which before was north still continued

so ; but four poles were observed in the needle, two consecutive to each other in the north part, and two others consecutive in the south.

“ 6. The middle of the needle was again placed upon the south pole of the magnet, and when its south part was drawn over the pole to a distance of 1| inches from the extremity, the needle turned upon the pin, and the end which before was south now became north. Each end, however, was repelled by the northern point of the other needle, and now three consecutive points, were observed.

“ All the phenomena remained the same as in art. 6, after the half of the needle, namely, the southern, had been drawn over the south pole of the magnet; and each end was still repelled by the north point of the other needle.

“ In these experiments it is evident, first, that the consecutive points which are found in a long needle, are more or less dependent on the different way in which the needle is drawn over the magnet. 2. That the same pole of the magnet may impart to the needle two opposite polarities, according as the latter is drawn from its middle to the right or left over the magnet. 3. That the part of the needle applied last to the magnet is endowed with greater forces than the other part; it was for this reason that the needle turned (art. 6 and 7). 4. We therefore see the error of the rule maintained by many of the learned, that the north pole of one needle always attracts the south pole of another; for there are many instances in which the south pole of one needle is repelled by the north pole of another, as we have already seen in our experiment. Hence, Gilbert [*De Magnete*\* lib. i. cap. vi.], undeservedly opposed the great Albertus Magnus, who said that in his time a magnet was found which with one pole attracted a piece of iron, and with the other repelled the opposite end of the iron, when it ought to have attracted it.<sup>1</sup> This however was perfectly true, if in the experiment performed by Albertus he used a needle such as our own.

<sup>1</sup> *De Mineralibus*, lib. ii. tract. ii. cap. xi., and tract. iii. cap. vi. (*Opera*\* Lugduni, 1651, vol. ii. pp. 233, 243).—Trs.

## "EXPERIMENT XCII.

" Whether it be the upper or lower, the anterior or posterior lateral surface of the needle that is drawn from the middle to the end, and whether it be drawn to the right or to the left over the same pole of the magnet, the same phenomena are observed in regard to direction and consecutive points as in the preceding experiment.

## "EXPERIMENT XCIII.

" The magnetic force having been wholly expelled by the fire from the needle employed in the preceding experiments, we found, nevertheless, that on cooling, it had acquired a directive force by which its head became directed toward the north and its tail to the south, as we shall explain more at large in chapter v. The needle, however, now exhibited a polar force only at its ends, when the other needle was brought to it; but no consecutive points in the intermediate part. The north point of the needle being applied to the south pole of the magnet, the needle was rubbed from this point towards its middle, but was drawn over the magnet only  $\frac{1}{2}$  of its whole length. When taken from the stone, the north end remained north, but sluggish, the directing force prevailing, but bringing accurately the needle back to the south. The north point of the other needle when held near the north point of this one, attracted it; but at a distance of 1| inches from this extremity a repelling force prevailed, and then again an attractive force extending to the south point; so that both ends of the needle were attracted by the northern end of the other needle.

"2. The rubbing of the needle was next extended from its north extremity to its middle or centre, and was effected over the same pole of the magnet. In this case the needle, when placed upon a pin, turned round; having its south pole directed toward the north, and its north toward the south. Both ends were attracted by the north point of the other needle, when placed near it; at about 4 inches from one extremity there was attraction ; through a space of 4 inches from this, and

therefore beyond the centre, there was repulsion : from this spot an attractive force again extended to the opposite end. But when the south pole of the needle under examination<sup>^</sup> faced the north cusp of the other, the south repelled it, and the repulsion extended to a distance of 4 inches from the end; from hence to the middle prevailed a state of indifference, or one neither of attraction nor repulsion. From the middle extending toward the opposite apex there was an attraction for the length of 2 inches ; and from this point to the end a repulsion again prevailed. The learned Hamberger seems to have made a similar observation in his *Programma Inaugurale de Partialitate Acus Magnetice* ; and although his observations do not exactly agree with mine, yet I have no doubt they are true, and were skilfully made ; for in these experiments there will be always some difference according to the time of the day, the season of the year, the length and structure of the iron, and the difference of the magnet which is used. He says, ‘ I drew the upper surface of a needle over the north pole from the end towards the centre : the needle when placed upon a pin did not spontaneously direct itself, to the north, though I observed in it some effort to do so, but in almost every position it was quiescent? In our own experiment we always observed the needle to have a direction exactly in the line of the magnetic meridian, although it did not touch the magnet; however the centre 0 of the needle (fig. 65, p. 480) had been cleaned from the scales produced by heating, and which by their roughness deprive it of its mobility. He then proceeds : ‘ When the north pole of the magnet was moved to the head of the needle, the latter receded; its tail, however, did not approach, but the entire needle, after several vibrations, stood still so as to be perpendicular to a line drawn through the poles of the magnet to the centre of the needle ; but when the south pole of the magnet was moved to the tail of the needle, the latter also approached to the pole of the magnet whose motion it followed. When the same pole was made to approach the head of the needle, the latter also approached to the pole of the magnet, and followed its motion; but with less

rapidity than the tail. The south pole of the magnet, therefore was friendly to both ends ; but the needle in respect of the whole magnet was partial ' (§ xi.). In our own experiment both ends of the needle were friendly to the north pole of the other needle ; an observation which is directly opposed to that of Hamberger. After the lapse of a month, however, I repeated the experiment, and the result agreed with the observations of Hamberger; for both ends of the needle were in amity with the south pole of the other. Nature is so prolific in her magnetic phenomena that she sometimes produces opposite effects; and thus in regard to the cause of her forces she makes a sport of the sagacity of mortals, and humbles the arrogance of their self-confidence. We may, however, easily understand the manner in which, in our first attempt, both ends of the needle were attracted by the same point of the other needle. For the south end of the needle placed before us was attracted by the north cusp of the other, before experiencing any contact with the magnet; and this force remained in the longest piece of iron, although the magnet was applied to the opposite end. Let us therefore conceive the north end to be drawn some distance over the magnet, which, therefore, becomes south, and that if it has sufficient power it would turn the needle, as it commonly does if the magnet be drawn farther over it. But the south pole is attracted by the north pole of the other needle; similarly the head of the needle, having acquired the force of a south pole, must be attracted by the north head of the other needle.

“ 3. The needle was next drawn along its whole length, in the former direction, over the south pole of the magnet. This being done, it had the same direction as in art. 2, but it had no intermediate consecutive points ; its north head being attracted by the south pole of the other needle; and its south tail being attracted by the north pole of the other.

“ 4. Finally, the tail of this needle which pointed to the south, was placed upon the north pole of the magnet, and drawn over it for the length of 2 inches. The direction of the needle remained

as above ; but both ends were repelled by the north pole of the other needle, and the intermediate part of the needle was attracted by this pole alone. This phenomenon must be explained “in the same manner as the first.

EXPERIMENT XCIV.

“ Figs. 67 and 68. Let ADBC be the polar side of a magnet, and let EF be a needle moveable upon the pin K; let the head, E, be applied to the point in the magnet A, D, B, or C; let the

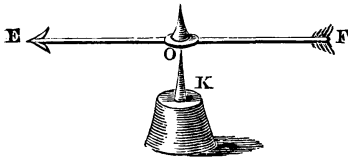

*Figs. 67 and 68.*

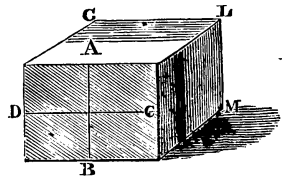

needle be then drawn along its length EF from E to F in the direction AB, DC, BA, or CD, or in any other similar direction between these points. The head, E, of the needle placed upon the pin, K, will observe always the same direction toward the same quarter of the heaven.

“ 2. Next let the tail, F, of the needle be applied to the same points of the magnet ADBC; and let the needle be rubbed against the magnet along the length FE from F to E in the direction from A to B, or D to C, as above; then will the head, E, of the needle, when again placed upon the pin, K, be directed toward the same quarter of the heaven as in the preceding case.

“3. Fig. 69. Let the same magnet be inverted so as to present to us a different pole GNLM. Let the head, E, of the needle be placed upon the points of the magnet G, N, L, or M, and let the whole needle be drawn from E to F over the pole in the direction GL, NM, LG, or MN. Then the head, E, of the needle placed upon the pin, K, will be directed toward the same quarter as in our second trial.

*Fig. 69.*

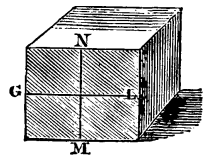

“ 4. Then if the tail F of the needle is placed upon one of the same points of the magnet Gr, L, N, M ; and if the whole needle be rubbed upon it from F to E in the directions GL, NM, LG, or MN, the head, E, will be directed toward the same quarter as in our first trial.

“ EXPERIMENT XCV.

“ Figs. 67 and 68, p. 487. If ADBC is the south pole of a magnet to which the head, E, of the needle is applied; and if the latter is rubbed from E to F, the head, E, of the needle placed upon the pin K will be directed toward the south quarter and the tail toward the north. But if the tail of the needle, F, is placed upon the south pole of the magnet and be rubbed from F to E, the head, E, will be directed toward the north quarter of the heavens. So that in order for the head, E, of the needle to look northward, it will be requisite always that the tail, F, be applied to the south pole of the magnet, and that the needle be drawn over this pole from the tail to the head.

“ EXPERIMENT XCVI.

“ Fig. 70. Let D be a glass cup full of water, and let the mariner's needle MS impregnated with magnetic force, or a small

*Fig. 70.*

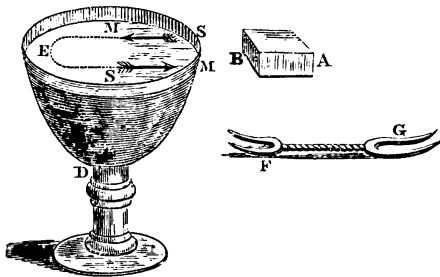

new common needle, be placed by means of a small fork FG on the surface of the water so as to float upon it. Then let the north pole B of the magnet AB be turned to the needle, the south point of which M will be attracted by this pole of the magnet.



Let now the magnet be turned round, so as with the south pole A to face the same point in the cup; then will the needle MS also alter its position, describing the curve SEM, and the tail S will face the pole A of the magnet.

“ This experiment, described by Poliniere in his *Experiences Physique*, Paris, 1728, pp. 291, 292, merits notice in consequence of the curve SEM, which the needle describes upon the water; for it might seem as if it turned itself only upon the centre of gravity just as a mariner's needle rotates upon the pin; whereas it describes a curve similar to that formed by filings sprinkled round the magnet ” (*op. cit.*, pp. 108-149).

The other observations adduced by our author on the declination of the magnet we shall omit; and pass on to his fourth chapter, where he treats of the action of one piece of iron endowed with magnetic forces upon another piece (see p. 235 of his work); and then we shall proceed to experiment ex.

“ Since iron endowed with magnetic forces does not differ from a magnet itself, whether we regard the attractive force which it exercises upon other iron, or its directive power, or its power of communicating its virtue to other iron, we might waive the examination of iron, in so far as by attracting other iron it shows its magnetic virtue. Still we cannot treat the magnet in the various ways in which iron may be treated ; for we cannot force the stone into any required form ; we cannot twist one about the other, nor elongate it by drawing it through an aperture : nor change its shape by hammering, and subjecting it to the same bendings and changes as a ductile metal. It remains, therefore, to examine the manner in which the magnetic virtue resides in iron, which is capable of being treated, and twisted about, in ways very different from any to which we have hitherto been able to subject the magnet.

## " EXPERIMENT CX.

"I see that it is remarked by some philosophers, that the magnetic force decreases in a steel plate if other thin and not large pieces of iron, which have never been drawn over the magnet, be rubbed against it; but that the force remains entire if larger bodies are applied; of which too considerable a mass, scorning as it were the magnetic forces of the thinner lamina, withdraws nothing from them. But were this opinion true, still it would not affect what we have said on the magnet in our second chapter, containing experiment xxxviii.; namely, that the magnet never loses any degree of its forces, even though six hundred pieces of iron should be drawn over it in a short time ; and this, whether they be thin and short, or thick and long. Hence I suspect that the experiment with the iron was not conducted with sufficient attention and caution; nor is my suspicion unconfirmed by facts. A steel plate 12 inches long, f wide and thick, drawn over the pole of a magnet, received an attractive force. I examined what weight of iron the plate carried from either extremity, so that I might know the magnitude of the forces. The weight being ascertained, twenty plates were brought into contact with and rubbed against the same extremity. These had never before scented a magnet; they were all equal and similar to the former. All these derived magnetic force from the rubbing. I then tried what degree of weight the former plate now raised; whether its attractive forces had decreased after being communicated to twenty other plates; or whether they remained the same; and I found that they carried the same weight, and with the same facility as before; whence I concluded that iron communicates indeed its forces to iron, but in such a manner as to exhibit only a profuseness of forces, without losing any of them by the communication. Whence then arises the error of those philosophers who maintain, that the forces of the iron are in this case diminished ? We reply, from the following source. When several plates are drawn over the iron, the loose parts which adhere to its extremity are rubbed.

If therefore you attach to this end any given weight to be carried, it is not attached directly to the metal, but to intervening particles; hence the weight, which is thus separated from the iron by an interval, cannot be attracted with so great a force ; as is shown by the experiments adduced in our first and second chapters. This I affirm to be the true cause of the error ; for on first making the experiment, I was inclined to think that the opinion of these philosophers was not contrary to the truth: since I found that a plate carried less weight after being rubbed by the others, than before ; but on observing the parts adhering to the extremity, and wiping them away, I found the plate capable of sustaining its former weight.

#### “ EXPERIMENT CXI.

“ I next thought it desirable to ascertain the quantity of force received by the twenty plates rubbed over the first which had before been applied to the stone. In all these I found the attractive force to be nearly equal; but in each to be less than in the first plate. On one of the twenty I rubbed a large knife which was impregnated with magnetic force, but with less than that which was in the plate to which it was applied. On this knife I rubbed another, and again another, and on this again a fourth. The latter, however, received so little virtue as to attract scarcely a particle of filings, or of Virginian sand, such as it had before done. Had I been in possession of more steel plates equal to one another, I would have continued to rub them in succession as before, and have noted the proportional decrease of the forces ; but not possessing them, I was obliged, in extending the experiment, to make use of knives.

“ We thus see that iron communicates its force to iron, but in a less degree than itself possesses. Consequently the force communicated always decreases in proportion to the greater number of iron bodies which are successively applied to it. It is, therefore, a property of the magnetic virtue :—1. To remain the same in quantity in iron, even if the iron is touched with numerous other pieces of iron. 2. To generate or excite

in a piece of iron of equal size a magnetic virtue less than its own. Consequently, it cannot pass out of one piece of iron into another; because the same which before existed in the iron still remains.

“ EXPERIMENT CXII.

“ Because iron and steel plates, when rubbed upon a magnet, are changed into true magnets, some philosophers have attempted, out of several plates placed one upon the other, to

*Fig. 71.*

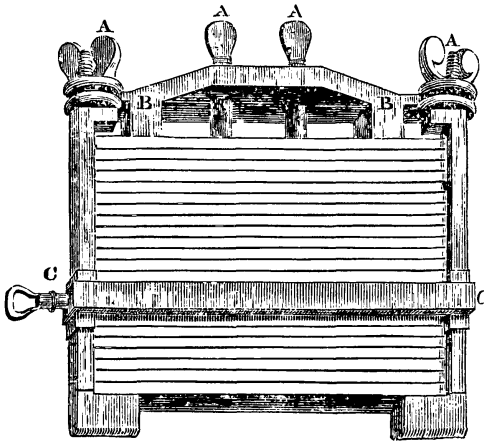

form an artificial magnet which shall attract, lift, and carry iron, as also communicate its force to other iron like a true magnet. This method of building up a magnet may not be unacceptable to the reader, nor useless for me, to record. A number of steel plates are chosen, well tempered, or hardened to the same degree of elasticity as sword blades. Throughout their entire length they are equally broad, thick, and highly polished. Their most convenient dimensions are 12 inches at least in length (longer ones are still better), J inch wide, and A inch thick. These, after being well impregnated with the forces of a liberal and good magnet, are placed one upon another in such an order that the similar poles touch each other; and all accurately fitting form

as it were one united body or block represented in fig. 71. To this body is applied an armature such as is used for a magnet, which, by a brass band CC furnished with a copper screw, is so tightened as closely to conjoin the extremities of the plates with the feet of the armature. The plates are also closely pressed together, so as to constitute one compact body; for which purpose there is attached at the top a copper beam BB, which, by aid of the four brass screws AAAA, is strongly forced down, thus uniting the plates into one solid mass.

“ The greater the number of plates used in composing the magnet, the longer they are, and the more liberal the stone over which they have been drawn, the more powerful also will be the artificial magnet. For the plates are each individually like a magnet, and the force of one assists the force of the other. Therefore, as the number of plates is increased, the sum of the forces is increased ; just as when several magnets, formed into one, have a greater power of attraction than any one of them taken separately. The quantity of attractive forces, however, at each foot of the armature, is not according to the number of plates, but is in a less proportion ; because the more distant the force is from the foot, the weaker it is ; as I have above demonstrated in the case of the larger magnets, the force of which is always proportionally less than in the smaller. We must here notice the observation of Hartsoeker, which he inserted in a paper entitled *Edaircissements sur les Conjectures Physiques*, p. 92. The attractive forces of each of the plates, which were of the same magnitude as those before described, he found to be 6 ounces. A magnet, composed of eighteen of these plates, lifted an iron weight of 6 or 7 pounds. After the lapse of six weeks, this magnet was the strongest and carried most weight. Each of the plates, however, when examined separately, was very weak, sustaining only an ounce and a half or two ounces. These placed one upon the other carried only as much as they did before their separation ; while in the meantime both their poles possessed equal forces. Nor is there any doubt concerning this observation; because I found the case to be the same with my own artificial

magnet. The magnetic force does not seem capable of being received by the armature of the plates so well in the beginning as after the lapse of some time. Besides it is uniformly and constantly distributed throughout the united mass; so that both its poles are capable of carrying an equal weight.

“ EXPERIMENT CXIII.

“ Let a small piece of iron wire, extremely flexible and drawn over a magnet, be impregnated with its forces; let it then be twisted into various forms and different angles; and let the bendings be so forcible as to leave a mark of inflection or of roughening of the surface ; in this case nearly all the attractive force will be seen to be banished from the wire.

“ In these bendings the situation of the parts is changed, other parts, different from the former, being brought into contact with one another after the bendings. No portion of the substance perishes; no accession to the iron is made; its pores are not clogged, but only a little changed ; and yet the magnetic force before communicated is now destroyed. We have observed the same circumstance to occur in iron endowed with magnetic forces. When hammered it entirely lost them; and yet by these means it was only the arrangement of the parts of the metal that was changed. The cause of magnetism is, therefore, of such a nature, as to require throughout the whole of the iron the same arrangement of the parts which it had when it was drawn over the magnet; and it perishes or flies when any other disposition of the parts is anywhere induced upon the iron, or throughout the whole mass; nor can it revive except by rubbing the iron thus bent against the magnet. It is, however, surprising that the force does not survive in that part of the iron which is not bent, and the parts of which retain the same arrangement as at first.

“ EXPERIMENT CXIV.

“ A piece of iron wire, or an oblong plane plate, received considerable virtue from a magnet, by which it raised an iron weight at its extremities. It was then bent into the form of a ring, and

both extremities touched each other. But immediately upon this, nearly all the magnetic force disappeared from the iron; nor was iron of any size taken up at the juncture of the extremities ; indeed, the greater part of the directive force was destroyed.

“ This has been observed by many of the learned; by Grimaldus, in his *Physico-Mathesis de Lumine, Coloribus, et Pride*, prop. vi. sect. 44 ; by La Hire, in the *Philosophical Transactions*, vol. xvi. p. 349 ; by Derham, in the *Philosophical Transactions*, vol. xxiv. p. 2139. The latter, having given great attention to phenomena of this kind, has remarked, that all the directive force perishes if during the day-time the wire remains bent into the shape of a ring, and is afterward stretched out longitudinally ; but that only a part of the force disappears, if the experiment be made in the evening. Nevertheless, the same extremities of the wire are attracted by the same pole of the magnet before and after the flexure.

“ Anyone conducting this experiment ought to note that care should be taken not to bend the wire gently so that when left to itself it may not return to its original form. It must be bent with a certain amount of force in order that it may remain permanently bent. The result of the experiment is best seen, by twisting the wire a few times round a cylinder in the form of a spiral. In this case, after being drawn over the magnet, one extremity of the iron wire is a north pole, the other a south. When the iron is bent so that the poles touch, the force going out in an opposite direction and balancing it, the two necessarily destroy each other; so that another piece of iron cannot be attracted. For in the same degree in which it is attracted by one pole of the wire, it is repelled by the other: so that when acted upon by both together, the one action nullifies the other. But because each pole is attractive, it ought to retain its force; in fact it does retain it unchanged, if the wire is bent only so much as that it can spontaneously return to its former rectilinear position. It, however, loses a part of its virtue, if it is so bent that the arrangement of the parts is changed, and the surface roughened ; as has been demonstrated above in experiment cxiii.

We do not, however, as yet understand the nicety of the observation of Derham ; for how is the morning or evening able to influence the magnetic forces, so that in the former case they continue and in the latter disappear ? It cannot be the light that conduces to this result; for then the force would remain in the twisted wire in the day-time, rather than in the evening. Neither does heat or cold cause it by rarefaction or condensation ; for winter days are colder than summer nights ; and if it depended on cold, the force would always be found to survive in winter. All we can do then is simply to take note of this surprising property of the magnetic virtue.

“ EXPERIMENT CXV.

“ If one end of an iron wire, impregnated with magnetic force, be held firmly in a pair of forceps, and the whole of the wire' be twisted by holding the other end, so that the axis always remains the same or immoveable, and thus the internal arrangement of all the parts is changed; in this case, after the completion of the various twistings, the directive force of the wire is observed to be considerably weakened, and sometimes inverted; so that the end which before was attracted by the north pole of the magnet, is now repelled by it. This experiment, conducted with different wires, has been found to exhibit different phenomena ; for before the wire was twisted it had no consecutive points ; but afterwards it seemed to have been endowed with several, for when the needle was moved along the length of the wire, it was at one time attracted at the north end of its axis, and at another time repelled ; as the very learned Derham has also observed.

’ “ EXPERIMENT CXVI.

“ It will, however, be desirable to show in what manner iron impregnated with magnetic force acts upon dust of iron, or upon Indian dust sprinkled around it. Let us commence with the most simple experiment (fig. 72). ACDB is a steel plate 12 inches long. After being drawn over a magnet, as described



in experiment cxxii., it was placed upon a flat sheet of glass. The plate was in the form of a long brick, and around it iron

Fig. 72.

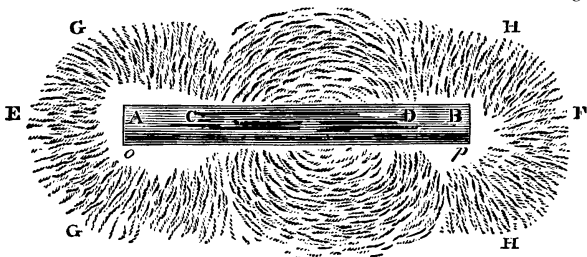

dust or Indian sand was sprinkled; it was scattered thinly in order that the series might be the better perceived. The glass being then gently tapped, the powder arranged itself into series such as are represented in the figure. These were distant from each other by unequal intervals. Those which were in the region of the ends A, B, lay in the same right line with the longitudinal axis of the plate; as we see indicated by AE and BF. The series surrounding each extremity of the plate, A and B, at the distance of 1| inches, that is to say, at C and D, lay also extended in right lines; although they surrounded the extremities, as is shown in GG, HH. The middle part of the plate CD was surrounded by iron dust arranged on both sides into

Fig

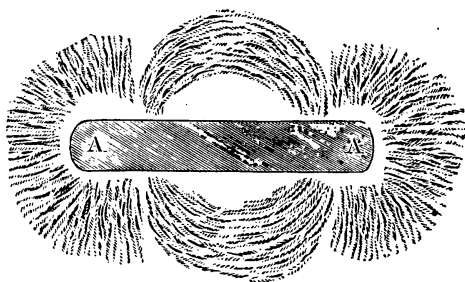

curvilinear series. These did not appear to be the arcs of circles, but portions of other curves.

“ When the angles of the plate were so shaped that each end terminated in a round head, some Virginian sand which was sprinkled around it, was arranged into series similar to the former, as represented in fig. 73 ; but when both the ends terminated in a sharp point, the series were disposed in a slightly different manner, as is seen in fig. 74. When the extremities,

Fig. 74.

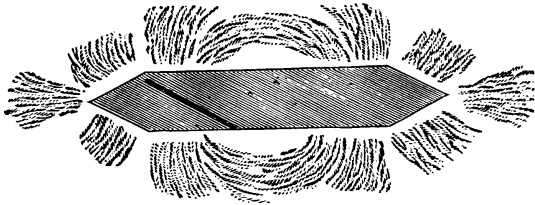

however, were cut, as in fig. 75, the series were arranged in a still different manner. For from every angle they radiated rectilinearly as from the centre of a circle; in the interval between each point of the same side they inclined toward each other, but nevertheless did not touch each other. The middle of the plate, as before, was surrounded by curved series.

Fig. 75.

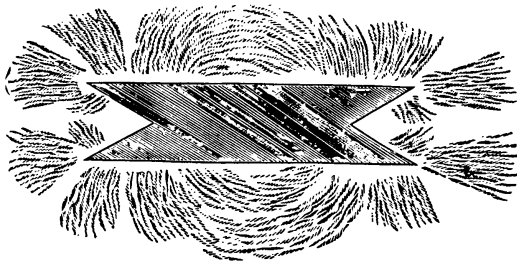

“ In the case of the square plate exhibited in fig. 72, we examined in what manner it attracted the dust upon which it was placed. To the thinner side  $o p$ , a large quantity adhered ; especially to the angles  $o, p$ , as also to the longest side between the angles  $o, p$  ; and a portion only to the plane surface.

“ EXPERIMENT CXVII.

“After this I placed upon the smooth surface of a sheet of glass, two steel plates A, B, impregnated with magnetic force (fig. 76);

Fig. 76.

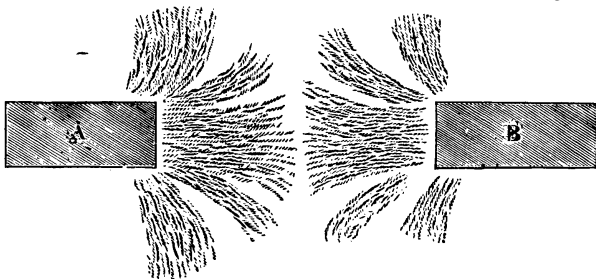

so that the two similar poles faced each other. In this case the Indian sand, which lay sprinkled about, was arranged into a rectilinear series proceeding from the polar surface. These were curved at the middle of the intervening space; turning away from each other in such a manner that no particle of sand in the sphere of the forces of the plate A was attracted or adhered to the particles lying round the plate B. But when either plate

Fig

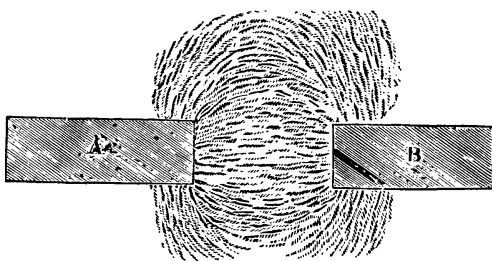

was turned round, so that the two poles of opposite names lay facing each other, the Indian sand arranged itself in a manner altogether different, as in fig. 77 ; where the particles attracted each other and are seen to receive a certain direction from the forces of each plate. In this case the series lay extended, in the middle of the intervening space, in a rectilinear direction ;

then on both sides they afterwards became curved in a greater or less degree, according as they were nearer to or farther from the middle; as will be seen from the figure better than from any description.

“ This order of the series does not differ from that occasioned by two magnets placed obversely to each other ; for, when similar poles face each other, the iron filings take the direction given in fig. 76; but when the plates and poles of opposite name face each other, the filings become arranged as in fig. 77. This is not surprising ; because iron drawn over the magnet, is impregnated with forces of the same kind, which in no respect differ from the magnetic forces.

#### EXPERIMENT CXVIII.

“ Fig. 78. Let AB, CD, be two steel plates touching each other at B and C. Let a magnet be applied to their extremity,

*Fig. 78.*

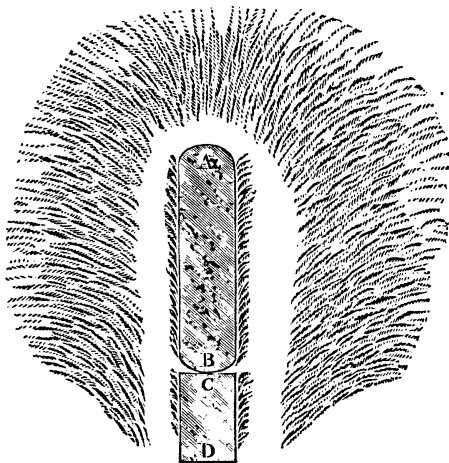

and let filings be sprinkled round the plates ; then will a small portion of them adhere to the sides ; another portion more remote will be arranged into series, extending anteriorly from the region A in a right line, but curved at the sides ; which will incline to

the magnet the more according as they are the nearer to it. In *Histoire de VAcademie Royale des Sciences*, 1717, *Mem.*, p. 275, La Hire mentions a similar experiment conducted by himself. Let us compare this order of series with that which is represented in fig. 73 (p. 497), and we shall observe a considerable difference ; entirely depending on the application of the magnet to the plates,\* or its withdrawal. In fig. 78, its force passes in a right line along the length of the plates; from the sides of these it lies extended almost rectilinearly; so that the curvilinear order ceases, which otherwise would surround the middle of the plate.

“ EXPERIMENT CXIX.

“ Fig. 79. Let AB be an entire ring of steel 2 inches in diameter. In conducting the experiment, the part A was drawn over the north pole of the magnet, and the part B over the south pole.

Fig. 79.

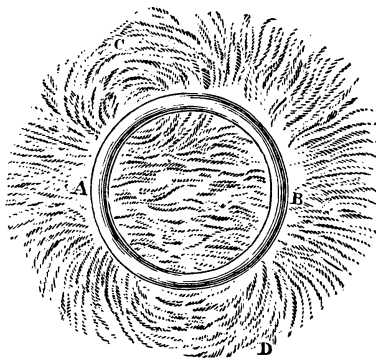

Around the ring, which was placed upon a glass plate, iron filings or Indian sand were sprinkled. That part of the sand which lay near the rubbed places received the direction of a rectilinear series; but at some distance from these places there were two curvilinear series formed opposite to each other, as C, D. The sand, which was lightly sprinkled in the middle annular space, was arranged into curvilinear series from the

region C and D; but for the most part was disposed in the same direction as the series near the rubbed places. The celebrated La Hire first performed this experiment which is described in the *Philosophical Transactions*, vol. xvi. p. 344. He stated that he had rubbed upon a magnet a plate of iron with an end like a knife; and that the end, when turned to the ring, had attracted various parts, and not merely one only or the other only, such as A or B, as happened in the case of the mariner's needle; moreover that a steel ring rubbed upon a magnet had for some time retained its virtue, although the poles were placed contrariwise to the poles of the earth. He also remarked that a steel ring, rubbed with a very powerful magnet, receives with difficulty a contrary direction if it be drawn over a weaker magnet with an opposite determination; for although at the beginning it would seem to have lost its direction, yet in process of time its force and direction are recovered; just as happens in the case of two magnets of unequal force, the stronger of which, when their similar poles are applied one to the other, repels the directive force of the weaker and induces a contrary one ; but when the two are again removed from each other they gradually recover their former state.

“ EXPERIMENT CXX.

“ Fig. 80. The extremities A, *a*, of two iron semicircles AB, *ab*, were rubbed upon the north pole of a magnet, and the extremities B, *b*, upon the south pole. Then around both, placed upon a sheet of glass at a little distance from each other, Indian sand was sprinkled rather thinly; which at the ends A, *a*, and B, *b*, was arranged into rectilinear series ; while at the middle of each semicircle were formed curvilinear series at C and D. In the space intercepted by the circle, the sand was disposed into straight lines, except a small portion which was in the region of the points C and D. The orders of the series were perfectly similar to those exhibited by fig. 79 (p. 501), in the case of an entire ring ; so that the former may be understood and explained from the latter.

In fig. 80 A and a are two similar poles mutually repelling each other; for both these ends were drawn over the same pole of

Fig. 80.

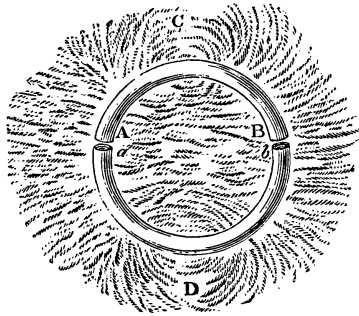

the magnet. Thus B & also are two similar poles mutually repelling each other ; therefore at the ends there are in this case four poles. But because these produce the same effects which we have noticed in the case of the entire ring (fig. 79), in that case also there will be four poles, of which the two similar will adhere to A, and the two others to B. The entire ring, therefore, in the two parts diametrically opposite to each other, when rubbed over both poles of the magnet, will have four poles ; two in each of the parts attracted.

Fig. 81.

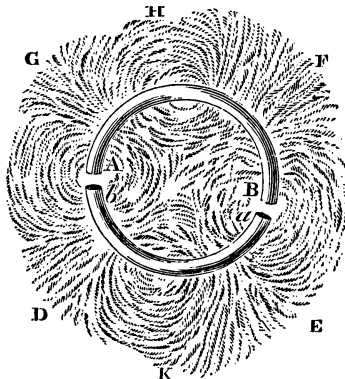

“ If now either semicircle be turned, as in fig. 81, so that the

pole A faces the similar pole 6, and the opposite pole B the similar pole a, but so that there shall ' be some interval between them, then around the ends there will be formed curvilinear series surrounding A and 6, as also B and a, to a considerable width. In the whole were seen four curvilinear series, and between these, four rectilinear series which La Hire, in the *Philosophical Transactions*, vol. xvi. p. 347, has also described as very beautifully arranged in the same manner.

“ EXPERIMENT CXXI.

“ The celebrated Derham<sup>1</sup> conducted several experiments with pieces of iron wire ; which, after being endowed with magnetic forces, were split longitudinally; in which cases he observed the following phenomena. 1. The poles were frequently inverted, so that the north became the south ; just as if the wire had been drawn afresh over the magnet in a direction opposite to the former. 2. Sometimes one half of the wire preserved the same magnetic force, while the direction of the other half was clearly inverted. 3. Sometimes no change was induced upon the magnetic virtue, with the exception merely of a decrease which takes place in all wires upon being split. 4. When one part of the wire experienced after cleavage a change of direction, this part was always the thinner ; the thicker remaining the same. 5. Sometimes after cleavage the pole of one part of the wire had been changed, while the other extremity remained indifferent, or was attracted by the northern pole of the magnet and by the south equally. 6. Sometimes one part of the wire was attracted by one pole, but the same extremity was neither attracted nor repelled by the other pole of the magnet, as if it knew not whither to turn. The learned Derham suspected at first that the change of direction arose from the violence experienced by the wire in splitting and bending ; but this opinion he afterwards rejected, observing that in the case of some wires that were split and but little bent, one half had experienced a change while

<sup>1</sup> *Philosophical Transactions*, vol. xxiv. p. 2139.—Trs.



the other part remained the same; also that the direction remained the same in the case of some wires that had been greatly bent. Besides he observed that it was the same thing whether the splitting was begun from the north pole or from the south.

“EXPERIMENT CXXII.

“ Because iron wire by splitting acquires one surface that is flat, namely, the part traversed by the wedge, and another surface that is curved; there is a considerable difference in the direction, according as the wire is placed upon a plane, and its flat surface made to face upwards or downwards. If the curved surface be uppermost, while the flat one lies horizontally underneath, then the wire will be attracted by the two poles of the magnet, and will be also repelled by them. If the wire be turned over, so that the flat surface looks upwards, then one extremity will be attracted by one pole of the magnet and repelled by the other. This has been closely observed by Derham,<sup>1</sup> who thought that the change of the direction depended upon the conversion of the poles produced by the splitting, which caused the north pole to become south ; but he was never able to discover that the sides of each end, or of the other part, were the same, on opposing the magnet either to one side or the other.

“EXPERIMENT CXXIII.

“ Let a plate of steel 12 inches long, such as is used in making an artificial magnet, be impregnated with magnetic force; then let a fresh iron rod or plate not very thick be placed on a blacksmith's anvil; and it will be found, when the end of the first plate is applied to this rod, that the latter will indicate a great attraction, by cohering strongly to the plate. But if the rod be placed upon wood, upon stone, upon the hand, or upon any other body not iron, then its attraction by the first plate will be two or three times less. The larger the anvil on which the rod is placed, the greater will be the force with which the rod is

<sup>1</sup> See note, p. 504.—*Trs.*

attracted by the plate, and the greater height from the anvil is it capable of being raised.

“ For this observation we are indebted to Reaumur, in *Histoire de VAcadAnie Roy ale des Sciences*, 1723, *Mem.*, p. 81; in which we observe the same effect produced by a large anvil which is produced by the magnet. Two keys, applied to each other over a magnet at a considerable distance from it, cohered with a force issuing out of the stone. The same force issues out of the anvil that excites attraction in two plates placed in contact with each other, or that increases it when excited, which is the same thing. In the same way that keys, held at some distance over a magnet, were attracted to each other with a less force than when held lower down, so that one fell from the other; so also the rod adhering to a plate held at a distance above an anvil falls down separated from it, provided the plate be made to recede from the anvil; another proof that iron is a magnet, and differs from it only in this, that it is possessed of a less degree of force, unless it shall previously have been made to touch a magnet.

#### “ EXPERIMENT CXXIV.

“ I next twisted round each other two iron wires, just as rope-makers twist two ropes in making a larger. The length of the wires was 4 inches; the diameter of an inch. This I drew over the south pole of a magnet. With each end they repelled both the north and south pole of the needle ; while with the middle part they attracted both poles. These wires were then bent, so that similar poles touched each other. Both ends possessed a cleft head, each of which attracted the north pole of the needle and repelled the other. The two opposite heads attracted both the south pole and the north; while the whole of the intermediate substance of the wires repelled the north pole, and kept the south motionless and in suspense. 2. Two other wires of the same length were twisted around each other; both of which had attracted with one end the north pole, and with the other the south, and again had reciprocally repelled

it as good mariner's needles do. These wires were twisted into one. and terminated in a cleft head ; with one end they attracted the north pole of the needle ; with the other they repelled it; but with each end they repelled the south pole of the needle. With the intermediate portion of their length, when opposed to the north cusp of the needle, they kept it motionless, neither attracting nor repelling it. They attracted, however, the south point. This experiment is of such a nature as not to be easily understood, however clearly described, unless a person undertakes to repeat and try it in different ways.

“ EXPERIMENT CXXV.

“ Some iron wire, which was 4 inches long, was drawn over the magnet; with one end it repelled each pole of the needle; with the other attracted the north pole, and repelled the south. The end which had repelled both poles, being hammered upon a stone and flattened, repelled, though but feebly, the north pole of the needle and attracted the south. The other end of the wire, which also was flattened by hammering, attracted the north pole, and repelled, though but feebly, the south. The intermediate portion of the wire was endowed with two consecutive points; one of which repelled and the other attracted the north cusp of the needle. 2. When this wire had been drawn over the south pole of the magnet, one end was observed to attract the north pole of the needle, and the other the south pole. When the middle was struck with a hammer and flattened to the length of 1 inch, the directive force at each end remained the same, but much enfeebled ; nor did the intermediate length seem to be endowed with any consecutive points.

“ EXPERIMENT CXXVI.

“ I examined two pieces of iron wire 4 inches long, which had been rubbed against a magnet. With one extremity they attracted the north pole of the needle, and with the other the south. The similar poles of the wires were placed upon each other to the length of half an inch; and after receiving some

blows of the hammer upon a stone anvil, on which they became flattened together, the flattened end of one wire, when opposed to the northern cusp of the needle which it had before repelled, now attracted it; while the same end of the other wire repelled the north pole of the needle as before.

“EXPERIMENT CXXVII.

“ Because from our preceding experiments we might be induced to think that the changed arrangement of the parts which compose the mass of iron must originate a difference in the magnetic direction; I would observe that, before adopting this opinion, I deemed it advisable to undertake other experiments in which the arrangement of the parts is changed, but changed in a manner somewhat different from the former. A piece of iron wire, which was 4 inches long and of the same thickness as the foregoing, was drawn over the pole of a magnet: and with one end attracted the north point of the needle, with the other the south; nor in any intermediate part did it present any symptoms of consecutive points. The wire was now drawn through a somewhat narrow hole made in a steel plate, and by these means acquired a length of inches; the poles at each extremity remaining the same and exhibiting remarkable powers; but again no consecutive points were observable throughout the entire length. When the same wire was afterwards passed through a smaller hole, by means of which it became 7 inches long, the same direction remained as before; one end attracting the north pole of the needle and repelling the south, and the other end attracting the south pole and repelling the north; nor did any further reduction of the wire, by passing it through a smaller hole, induce any new direction, or change the former one. Still in these experiments the arrangement of the parts of the wire was changed, and in such a manner that probably there were none that before had touched one another which now adhered or remained contiguous to one another, but were removed to a considerable distance.

“ The changed situation of the parts, therefore, cannot be called

the universal cause of the inverted direction ; for there are some cases in which the iron has a different direction when its form is changed, and other cases in which no difference of direction is observable. To any one who in future may be so fortunate as to discover the cause of the magnetic virtue, these phenomena will become intelligible; although such as are mentioned in the present chapter are not the easiest to be understood. While we are ignorant of the cause of magnetism, we are only like moles burrowing under the earth. We go in search, we investigate, we move onwards in labyrinthine directions, sometimes meeting with soil altogether barren, sometimes with such as slightly rewards our labours. Let this, however, serve as our solace, that an experiment rightly conducted and accurately observed under all circumstances, always remains an experiment; that is to say, always true, and always in some degree useful, nor ever liable to those alternations which overtake even the most subtle arguments derived from a slender hypothesis.

“ EXPERIMENT CXXVIII.

“ Let a piece of iron which is not impregnated with any magnetic virtue, except such as it acquires spontaneously, be held near either extremity of a needle ; it will then change the direction of the needle, and attract it to itself just like a true magnet. The needle, moreover, will follow its motion, and be made to describe a circle or be made to stop at different points and be directed at will by only moving the iron. If, however, the latter be endowed with a magnetic force, it will attract the needle at the same distance as before much more strongly ; or if placed farther off, will nevertheless give indications of its influence ” (*op. cit.* pp. 235-249).

## CHAPTER XII.

### THE ACTION OF IRON AND THE MAGNET UPON THE MARINER'S NEEDLE ; AND THE RECIPROCAL ACTION OF ONE NEEDLE UPON ANOTHER.

#### A PRIORI OR FROM FIRST PRINCIPLES.

The sphere of the emanation around iron extends itself to a considerable distance; so that the vortices or gyrations of effluvia emanate like radii on every side, and dispose the magnetic element itself into the same arrangement; whence the magnetic element regards the iron as its pole or centre from which the vortices issue in a long series. Not only does a stream of emanation perpetually go forth from the iron, but it also presses upon and surrounds its surface ; a fact proved by so many phenomena bearing upon the conjunction of the magnet with magnetic needles, as to be placed beyond a doubt. We see the magnet taking to itself forces from the iron: we see the iron reacting upon the magnet just as the magnet acts upon the iron : we see the needles themselves turning toward the iron as toward their pole, always facing it and regarding it as a centre ; and this not only at a distance of inches but also of even feet and ells. And because, according to the theory advanced in the preceding chapters, there is no difference between the magnet and iron, with the exception that iron is not encompassed with a definitely connected and contiguous sphere extending from one pole to the other, we may consequently learn the nature of the sphere which surrounds the iron. The situation of the smallest parts both within the iron and also at its limiting surface is irregular. But because there are emanations which press upon the surface, and conjoin themselves with those which are within the iron, it follows

that the iron is entirely surrounded with a sphere which is bound up with the body itself. That this sphere, however, is not regular and connected, we have already shown. If it is not regular and yet is bound up with the iron body, it must be thus associated with all parts of the body; so that the sphere around the iron constitutes a certain species of contiguity. If it be thus associated, it can be only so in order that the gyrations or vortices may be mutually connected according to their spirals; if according to their spirals, this kind of connection will extend from the iron itself to some distance from it; and if so, then all round the iron. For the vortices can be united only in conformity with the course and mechanism of their spirals; that is to say, to generally form straight lines proceeding from the iron itself in every direction. And thus the vortices of the emanations extend themselves as radii to all parts around, according to the mechanism of their conjunction. But since the whole of this sphere has no configuration, nor connects itself by continuous curves from one pole to another; nor thus maintains a given relation to an axis, nor on each side the axis to its magnet, nor on the other hand the magnet to its sphere; it follows that, in the sphere belonging to the iron, no magnetic force can be present; for on the approach of another sphere, such as the magnetic, it immediately yields; since of itself it cannot conjoin anything with itself, nor can it repel or avoid it; because there is no connection of parts, no cohering and continuous association from one pole to another.

As is the arrangement of the vortices, or the form of the sphere, such is the arrangement, or form of arrangement, of the elementary particles vortically moved. In the fore-mentioned element the gyrations take place according to the axes and equators of the particles; for they begin in the centre, proceed after the manner of a spiral, and terminate according to the arrangements of the parts. If the vortices are conjoined as to their spirals they are conjoined entirely according to their motion, and the motion applies itself to the arrangement of the particles. Therefore as is the situation of the gyrations or spirals, such also is the situation

of the elementary particles, which must necessarily adapt themselves to that motion. From this we have the general rule, that the situation of the elementary particles is like that of the vortices; that the motion of the vortices brings the elementary particles into the same situation with its own; and that the arrangement of the elementary particles is such as is the form of the sphere, whether around the magnet or around the iron. The elementary particles therefore, with their axes and poles, so dispose themselves in every direction from each piece of iron, that they regard the iron as their centre ; and that their axes are radii and diameters, according to which the spirals and helices of all the vortices are conjointly enabled to embrace themselves at a distance from the centre. On these subjects, however, we have already treated.

2. Innumerable other spheres, whether pertaining to iron or to a magnet, may be formed within one and the same sphere ; and each sphere may act according to the arrangement and motion of its parts. It is like the case in other elements on a larger scale ; as for instance in the air, where a thousand sounds and modulations may spread from different centres either simultaneously or successively; in water, where a thousand undulations may spread one beyond and over another, and all within a larger one ; and especially in the ether, where there may be almost infinite centres and infinite modifications, one presenting no impediment to the other. An element which is in motion as to its volume, is neither displaced from its natural situation in respect to its particles, nor deprived of equilibrium. In their motion the particles observe the same reciprocal relation as in a state of rest. For local motion and translation do not belong to the individual parts, but to the volume. In this motion the particles must be regarded as in a state of rest; because, in respect to the neighbouring particles, they continue in their natural situation. Hence by reason of the motion among the particles there is no loss of equilibrium. Therefore it is of no consequence if a certain new motion exists within the sphere of the other motion, and another motion again within the sphere of this



motion. Nevertheless the particles have naturally a reciprocal relation to one another; for a common motion is as rest, relatively to the individual parts. Innumerable spheres therefore, whether pertaining to the magnet or to iron, may exist within a single larger sphere.

3. In every magnet there are qualities and forces of two kinds ; one, that of attracting another magnet or a piece of iron, which is called the attractive force ; the other, that of accommodating itself to the parallelism of the magnetic element, or to its poles, which is called the polar force or declination of the magnet. With regard to the first, it arises, as we have often shown, from the mutual connection of the gyrations, and the mutual conjunction of magnets and pieces of iron; with regard to the second, it arises, without the application of any magnet, solely from the elementary contiguous medium. For the magnet, when left freely to itself, and also the needle when rubbed upon a magnet, directs itself into its polar position, as it were, spontaneously; that is to say, into the parallelism of the parts of the elements.

4. Within the sphere of the iron, at some distance from it, the mariner's needle is turned toward the iron, not by an attractive force, but by its own polar quality. We say, not by an attractive or conjunctive force, because there is no action of vortices or spirals beyond an angle of forty-five degrees ; and the gyrations or spirals at a distance are too weak and sluggish to allow of mutual action. But since the arrangement of the elementary particles around all iron is diametral, or radiates from a centre, therefore the sphere surrounding the needle naturally disposes itself in accordance with the position and parallelism of such particles; because it is a mechanism ; and so the needle turns itself by reason of its own polar quality, and not by virtue of any attractive force. For if no iron were present, it would turn itself, conformably to the parallelism of the magnetic element, toward the poles of the world. But because in the present case, the situation of the same element around the iron is not toward the pole of the world but toward the iron, as stated above, it follows that the needle with its sphere seeks its equilibrium in this situation,

## 514 THE ACTION OF THE MAGNET ON THE NEEDLE.

and aims at a state of rest as a mechanism. According to our twenty-third thesis in the first chapter of this part, it is evident that the axis of the sphere, or the common axis of the vortices, lies most conveniently in a position parallel with the common axis of the element itself; but that it may yet be easily turned thence toward any other quarter. If it be caused to have regard to the iron, then it lies most conveniently in a parallel position ; because the elementary parts whose distance is proportionate to the size of the sphere, maintain such a relation to the iron as we see in fig. 82, where the needle takes up a position in accordance with the flow and situation of the parts. But because the needle is surrounded with a sphere of the same parts, it can only turn itself in accordance with the common situation of those parts.

5. How astonishing and manifold are the strange phenomena brought to light by the mariner's needle on applying the magnet

*Fig. 82.*

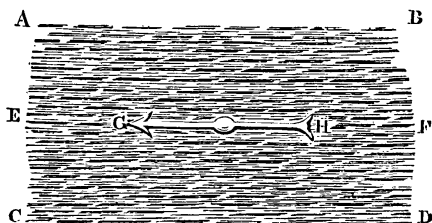

to it in different ways ! At one time we see it shunning its pursuer, dreading and recoiling from its presence and contact; at another, spontaneously hastening, indeed, rushing, to meet or embrace it. At one time obliquely stationing itself by its side, and eyeing the magnet askance as it were; at another, somewhat elevating its position and looking down upon it as with supercilious glance ; at another, lying along its side submissively, and watching the magnet laterally with attentive eye ; at another, flying away and rushing in a circle to the other side of the magnet, either to meet it or become its companion; and then again it is seen oscillating and moving its head, and amusing

the spectator with different fantastic and sportive vagaries according to the different motions of the magnet. And because the eye can see nothing beside the magnet and the needle, "both— of which are hard and iron substances, separated from each other perhaps by partitions of brass, one might almost imagine the intervention of some spirit or genius to be the cause of such extraordinary movements. But as all these motions arise simply from the contact of spheres, effected when the poles are either hostile or amicable to each other, when the equators, or the sides between the poles and equators, are applied above or below ; and as it would be tedious, moreover, to represent these varieties by figures, especially since the results have already been explained in chapters i., ii., iii., iv., v. of the present part; and as all possible modes and varieties may also be explained from the same causes and first principles, it will be sufficient to refer the reader to the several chapters already enumerated.

musschenbroek's experiments.

#### “ EXPERIMENT CXXIX.

“ It yet remains for us to examine in what manner two mariner's needles, endowed with magnetic force and placed in the same horizontal plane within the sphere of each other's action, act upon each other. One needle employed in this experiment was 6J inches long; another 9 inches. Each was placed upon its pin, upon which it could turn freely. One was parallel to' the other. Each with its north pole faced the north. The centres of each, or the pins, lay in a right line parallel to the magnetic equator; in which they were placed at pleasure, either nearer to each other, or farther off, just as the needles approached each other. The shorter needle was placed eastward of the longer. Then first, when the pins were at a distance from each other of 4 inches, both the north poles slightly approached each other; and the south poles receded to the same amount. When the pins were placed still nearer, so as to be distant one from the other only 3 inches, then the north poles slightly

receded from each other, and the south poles slightly approached. The same results were observable when the pins were distant from each other 2J, 2, 1| inches. But when they were brought still nearer, the needles turned round, and embraced each other with their points of opposite name.

“2. The same phenomena were observed when the shorter needle was placed westward of the longer.

“ 3. When the longer needle was placed in the magnetic meridian, the other was brought to it, but in the same meridian. In this case the direction of each remained in the same meridian ; the north pole of the one facing the south pole of the other. And this continued to be the case at every distance of the centres from each other ; provided they did not touch one another.

“ 4. When both observed the same meridian, one was turned round with the finger, and its north pole held steadily to the west; in this- case the north pole of the other also was spontaneously directed to the west; still it deviated from an exactly western direction by a greater or less number of degrees according as the centres were nearer to each other or farther apart.

#### “ EXPERIMENT CXXX.

“ Finally, two needles were placed the one over the other, so that the pins of both were in the same right line perpendicular to the horizon, and consequently the needles in different planes. Various experiments with these needles were formerly made by La Hire, which he described in *Memoires de VAcad&mie Royale des Sciences*, vol. x. p. 164; and as these were properly conducted and are well described, we shall furnish extracts from the author's own account.

“ 1. He took a box which belonged to a compass, and which was furnished with a copper circle divided into 360 degrees; from the middle of which projected a pin on which was placed a needle, freely movable, and 3J inches long. He turned the box until the needle pointed to 360 degrees. The box was then closed in with a plate of glass ; and he took another magnetic

needle of the same length as the former, which he placed upon the glass plate ; so that its pole pointed to the north, or was directly over the pole of the needle in the box, the one being longitudinally parallel to the other. The needle upon the glass lay motionless; but the point or head of the needle in the box turned round toward the west, and after some vibrations remained motionless at 42 degrees westward.

“ 2. The needle in the box veering at first, relatively to the needle placed over it, a little to the east, the north pole of the needle in the box continued to take a direction to the east, and after some vibrations stood fixed at 41 degrees eastward ; thus declining from its first situation toward the east, as much as in the preceding experiment it had toward the west.

“ 3. After this, the uppermost needle being removed, the needle in the box returned to 360 degrees. Then again the other needle was laid on the glass in such a manner that its north pole looked to the west, and both needles thus cut each other at right angles. In this case the north pole of the needle in the box turned eastward 13 degrees.

“ 4. The upper needle being again removed, and the other in the box remaining at rest, the former was laid upon the glass with its north pole looking to the east. In this case the north pole of the needle in the box moved eastward 13 degrees.

“5. As the north pole of the needle in the box, in our fourth experiment, was distant from the south pole of the upper needle above it 77 degrees, so now the south pole of the latter was brought nearer to the north pole of the former by 10 degrees ; in which case the north pole approached the latter by 5 degrees.

“6. When the needle laid upon the glass was made with its south pole to approach by 5 degrees to the north pole of the needle in the box, then, suddenly, the north pole of the one approached the south pole of the other; so that both needles lay, as it were, immediately one above the other ; nay, the pole of the needle in the box elevated itself so as to touch the glass in the part immediately under the upper needle.

“7. It now remained for experiments to be made with two

needles, both of which should be moveable upon a pin. These were so placed that the pins lay in one right line, that is, one directly over the other, and at a distance from each other of 10 lines. In this case both poles of the needles were directed northwards, not in such a way that the needles were parallel to each other, but that one deviated from the north toward the east, as much as the other deviated from it toward the west.

“ 8. The needles were then placed upon pins, with shorter axes so as to be nearer to each other than in the preceding experiment, and to be mutually distant only  $\frac{1}{2}$  of an inch. When both north poles were directed northward and left to themselves, then they spontaneously separated from each other to a distance of 46 degrees ; and when one veered to the east the other veered to the west.

“9. When the south pole of one needle was placed over the north pole of the other, then both embraced each other and remained in the same place ; whence they had no true direction northward or southward.

“ 10. When both the needles were rapidly turned round and then left to themselves, they did not come to rest till the north pole of one needle embraced the south pole of the other ” (*op. cit.* pp. 249-252).

## CHAPTER XIII.

### OTHER METHODS OF MAKING IRON MAGNETIC.

#### A PRIORI OR FROM FIRST PRINCIPLES.

IRON may be rendered magnetic in other ways than by friction and contact. The means effecting this consists merely in bringing the smallest parts that go forth in the form of an emanation, into a definite arrangement. By the friction of the magnet with the iron all the smaller parts or elements of the emanation are brought into a regular position; for they follow the course and tract of the magnet, and turn themselves in the direction in which the magnet precedes, and which it thus points out. How much force of attraction is acquired by the iron, is sufficiently evident from experience. For if the magnet is large, the iron will be able to support needles, and even large ship nails ; it will collect together the scrapings and filings of iron into the form of light chaff and straw, and draw them after it with a firm hold wherever it chooses, if it be not too quickly moved. These we may see suspended round the poles like a head of hair, or a beard; for one particle hangs in a state of connection with the other, forming in appearance a fence composed of many bristles or spikes ; and hence with still more facility does the force of attraction govern the congeries of the smallest parts of the iron. By mutual contact and approximation, therefore, it disposes at pleasure the tide of the minute parts in the iron which exhale in the form of emanation. Mutual contact is consequently the first and principal means by which iron is endowed and imbued with magnetic force.

But since it is evident that the cause of the magnetic quality

consists solely in the regular and parallel situation of parts, it may be possible to ascertain whether there are other means by which the same effect can be obtained. We know that the magnetic element flows always in a rectilinear, parallel, or perfectly regular arrangement; and has a continual relation to its poles. We know that this magnetic element is exceedingly subtle, and penetrates the smallest pores of bodies; especially if in the course of formation these pores have already been penetrated by the element. If iron, therefore, be exposed to the continual action of the magnetic element for a considerable and stated period, it will be rendered magnetic; particularly if it is placed in a position which coincides with the parallelism of the elementary particles. For from experience we may learn what is the declination, and what the inclination of the magnet. If iron, therefore, is so placed that its declination and inclination are the same as a magnet, then it probably will be imbued the sooner with the magnetic force, and will derive from its element its nature and character, and be rendered pervious in a parallel or rectilinear direction from one extremity to the other; just as when a mineral in the earth and in its matrix is born magnetic, or imbibes a conjunctive and polar force. For it lies there for a considerable time undisturbed, continually exposed to the element which thus enters its pores, and which regularly disposes the smallest part into conformity with its own arrangement, filling them with all its own force, and fixing it, as it were, in the stone.

Perhaps also the minutest parts are capable of receiving a regular arrangement by the iron being exposed after ignition to an extremely slow process of cooling; though some skill is required in causing the cooling to take place very slowly, and enabling it to acquire hardness by distinct gradations and stages. When iron is incandescent, the state of its parts is extremely unsettled, particularly of those which are less able to resist the action of the fire; for there are some which, like wax or sulphur, soften and liquefy with a very small degree of heat, and which with a high degree are made to boil like hot water;



there are some which yield only to the strongest degree of heat; some which yield indeed to heat, but are driven about from place to place with parts which are free ; there are others which remain immoveable, and seem to disregard the highest temperature. Nor are the motion, turmoil, and contention of the parts the less considerable during the process of cooling; for the fire hastens and, as it were, pants for contact with the cold and humid atmosphere, escaping at any outlet it can. Whatever opposes its passage it dislodges and disperses, and if it does not find a vent, it lacerates, breaks up, severs, and tears asunder the obstacle, not suffering itself to be pent in by the pressure of surrounding particles; for the liquid parts and those which cool less rapidly, it does not abandon at the same moment as those which are more stubborn and combine more quickly. Thus during the process of cooling, the iron does not dispose itself, as to its interiors, into magnetic order. Unless therefore it solidifies or hardens very slowly, and unless while cooling it is allowed to slowly come to perfect rest, any method of producing magnetism will be unsuccessful.

2. Iron may also be rendered magnetic by repeatedly stretching and bending it: as also by regular filing, and by hammering it out. For tenacious and ductile iron appears to consist of innumerable folds, thin plates, threads, and series, which during frequent bendings of the iron are continually stretched and rubbed one upon another, and as a result of this they begin not only to vibrate, but also to become warm; and they are ready, under the slightest influence of the magnetic element, or else by virtue of the relation of the component parts, to pass into a state of orderly arrangement. For by reason of the vibrations and heat, the parts are, as it were, left to themselves, because they have greater freedom, and are more at their own disposal, more obedient to every natural motion, and consequently disposed to flow concordantly into an orderly arrangement. And if under the regular blows of the hammer, or the action of the file, vibration is also caused and heat produced, so also, if the artizan be skilful, the parts can be made to assume some definite

arrangement suitable to magnetism. Experiments of this kind afford additional evidence in favour of our first principles ; namely, that 'all magnetic force consists entirely in the regular arrangement of the parts, and that all the effluvia from iron are magnetic. From these data flow, in definite order, all that we have hitherto ventured to maintain, concerning the modes and qualities of magnetic forces in the magnet and iron. Let experiments, however, speak for themselves.

musschenbroek's experiments.

“ The magnetic force is universally present, though latent, in all bodies made of iron.» Whether large or small, thick or thin, the iron clearly shows the attractive force which it exercises upon filings, Virginian sand, or the magnetic needle ; and it frequently possesses a directive force, by reason of which, when left to itself, it turns to the same quarter of the heavens as the magnet or the needle. This is not to be wondered at, because, as we have before observed, iron through length of time corroded with rust and infused into the pores of a stone, changes into a genuine magnet. Nor indeed need we be at much pains to find a magnetic force in bodies made of iron ; for all ploughshares, scissors, shears, nails, wedges, needles, or other manual instruments of iron, at any point or angle attract Indian sand or iron filings. This was known in the past to many, particularly to the studious and learned Gassendi<sup>1</sup> and Rohault<sup>2</sup>; while in the present day it has been further confirmed by Wolffe<sup>3</sup> and Reaumur in *Histoire de VAcademie Royale des Sciences*, 1723, *Mem.*, p. 81. Being about to treat of the magnet and its forces, I have thought it right not to omit the observations which have been taken with respect to the force of iron; since they are of the same nature as the former, and may throw some light upon them. Moreover as many of those things which were formerly affirmed of the magnet, I have either confirmed by

<sup>1</sup> *Animadversiones in Decimum, Librui Diogenis Laertii*. Lugduni, 1649, vol. i. p. 378.—*Trs.*

<sup>2</sup> *Physica*, par. iii. cap. 8, §§ 27, *et seq.*—*Trs.*

<sup>3</sup> *Vernunfftige Gedancken*, § 382.—*Trs.*

submitting to a fresh examination, or else have found to be erroneous ; so, in the present case, I have pursued the same plan by re-examining the discoveries of others, supplying their deffciencies, omissions, or oversights, and reducing to order what had lain scattered throughout the writings of different authors. These observations I have premised, lest it should be thought I was propounding trite remarks ; or passing off as my own the experiments of others.

“EXPERIMENT CXXXI.

“ A cylindrical iron rod, ih inch in diameter, and 6 inches long was placed upon a bright fire, so as to lie longitudinally in the meridian passing through the north and south poles. The fire was not kindled near iron, but only where stones were laid, lest the force of other iron should interfere with the experiment. Having been made red hot throughout its entire length, it was taken out of the fire gently and quietly with a pair of brass tongs, and was brought in a horizontal position near a moveable needle endowed with magnetic force; in doing this care was taken to keep the rod in the same meridian. In this case the south end of the rod attracted the north pole of the needle, and the north end of the same rod, when turned, attracted also the north pole of the needle.

“2. In place of this slender rod, we next took another twice as large in diameter, and 10 inches long, and used it in a fresh experiment, after having been well heated in the fire ; when taken out and presented to the needle, the same phenomena were seen as in the former case.

“3. Further, an iron rod 5 inches long and 1 inch square at the base, gave clearly the same results.

“ These experiments may be made with a needle enclosed in a brass box covered in with glass ; for the fire escapes with such great impetuosity from the iron under examination, and so shakes the needle if unprotected, that tremors, oscillations, and other unusual motions, are set up in it, which impede observation in regard to the attraction.

“ The magnetic force therefore, whether in a stony or iron

substance, acts upon ignited iron by attracting it. That a magnet attracts red hot iron is confirmed by Colepresse in the *Philosophical Transactions*, vol. ii. p. 502 ; by Muller in his *Collegium Experimentale*, Nuringbergse, 1721, p. 229 ; and by our own experiments adduced in chapter ii. We here say then, that the magnetic force of the needle acts upon heated iron; and this we state in opposition to Gilbert, who denies the fact in *De Magnete*, lib. ii. cap. ii. p. 52.

“ 2. We remark also, that in heated iron there is no directive force ; for if red-hot iron had poles, it would not attract indifferently either pole of the needle. But although one of the pieces of iron might exhibit this property, yet it might not obtain in the other two also ; for we confess that notwithstanding we may sometimes find wires both of whose extremities attract the same pole of the needle, this occurs but seldom. And yet we observed this, on three different occasions, in the case of hot iron, and never otherwise. Therefore, there is either no directive force in hot iron, or else it is infinitely small.

#### EXPERIMENT CXXXII.

<sup>44</sup> If extremely thin iron rods, such as were used in experiment cxxxi., are made red hot, and carefully and gently taken from the fire with brass tongs, and placed upon a stone floor for the space of an hour in the terrestrial or magnetic meridian, then if the north end be placed at the south pole of the needle, it will attract the latter but repel the north pole. The south end of the rod will, however, attract the north pole of the needle but repel the south pole.

<sup>44</sup> If any long cylindrical slender rods, such as those over which the curtains of windows or beds are drawn, lie for some time in a direction parallel to the horizon, in the terrestrial or magnetic meridian, then, whether they are upon the ground or are placed higher up and suspended in the air, they are imbued with the same directive magnetic force ; and with the ends which have been turned to the north they attract the south pole of the magnet needle and repel the north.

“ I will here add an observation from which it will be evident, that physicists have for the most part generalised upon the properties of the magnet, without having carefully and accurately noted all the circumstances attending their experiments ; this they ought to have done. For this reason, having had much experience in performing these experiments, I have detailed every particular without the smallest exception; and hence to some persons I may appear to be exceedingly diffuse, although, unless the details are noted and compared with one another, errors will necessarily arise. Any one, therefore, on first reading over these experiments, might not yield to the opinion that iron placed in the meridian is impregnated with a directive magnetic force. Let him not, however, be too precipitate ; for these experiments are made only with long and slender rods ; but will the same phenomena hold good of thick ones ? Let us enquire into this subject; for it is a task which will repay our labour ; for in iron 1 inch in diameter or thicker, but shorter than 8 or 10 inches, I could never observe any directive force of this kind, even though it lay in the meridian for some days.

“ Let us consider the analogy between the force of the magnet exercised upon iron, and the universal magnetic force, as resulting from a magnet, supposed to be enclosed in the centre of the earth, exercised upon iron. The magnet requires iron plates of only a certain thickness, to which it communicates its force, thicker plates not being susceptible of any action. Similarly, iron is required to be of a certain length and thickness, which, when left to itself, spontaneously acquires magnetic force. I do not doubt that all iron, however thick, may be impregnated with a magnetic force, provided it be sufficiently long. But there is required a certain proportion between the thickness and the length; what this proportion is I do not know, as I have not yet made the necessary experiments.

“ The authors of the foregoing observations add, and rightly, that red-hot iron, placed in the meridian, is more quickly endowed with a directive magnetic force than iron that is cold. Slender and long pieces of iron, therefore, spontaneously acquire a directive

force by which mariner's needles or compasses are acted upon, provided they have lain some time in the meridian. We can, therefore, obtain a needle without the aid of a magnet, and ascertain its directive power. Take, for instance, a slender and long rod, passed through the middle of a small cork so as to float on water in a large bowl, in a perfectly still place ; one end of the iron will turn toward the north, just as in the case of the needle; this turning and direction, however, are attained by a very slow motion. The same result is obtained, if a rod be suspended by an extremely fine silken thread not twisted ; as we are informed by Gilbert, *De Magnete*, lib. i. cap. xii. p. 32. The force, therefore, which the interior magnet of the earth communicates to the iron is not immediately destroyed, but remains for some time ; and causes that part of the iron which last faced the north to turn to the north.

#### “ EXPERIMENT CXXXIII.

“ Having in our preceding experiment examined iron that had been placed in the meridian, we now had to ascertain what occurred in iron laid parallel to the equator of the earth, and in a position cutting the meridian at right angles. With this view an extremely slender iron rod, such as was used in experiment cxxxi., was made red hot; it was then carefully taken out so as to avoid any concussion, with a pair of brass tweezers, and was left to cool upon a stone floor, in a direction parallel to the equator of the earth, and at the same time in the plane of the horizon. When cold it attracted the south pole of the needle, and repelled the north with the end which had faced the west. But it required to be brought an inch nearer to the needle than before, in order to enable it to manifest its virtue ; so that after cooling in this position, it was found that the degree of force was less than after it had laid in the meridian. I had before seen the forces of the western end attracting the south pole of the needle. For in this part of the world, and in the present year, the magnet declined toward the west  $13^{\circ} 20'$ ; and, therefore, when the rod was placed parallel to the equator of the earth, the western end remained

in the northern hemisphere of the magnetic forces ; and hence, having acquired the force and direction of a north pole, it could not but attract the south pole of the needle, and repel? the—north.

“2. The magnetic equator having been accurately marked out on a stone floor, the same rod, which had first been made red-hot, was left to cool in the equator; and after this it attracted with each end the north and south pole of the needle; so that the rod manifested a perfect indifference, having no poles; a result which could not but follow.

“ 3. The same rod, after being made red-hot, I again placed upon a stone floor so as to cut the magnetic meridian at an angle of  $45^\circ$ , and with one end to face the north-east, and with the other the south-west. The western end of the rod when cooled, attracted the north pole of the needle, producing no effect upon the south pole. The eastern end of the rod attracted the south pole of the needle ; producing no effect upon the north pole. These experiments were conducted with the greatest care, in a place free from the vicinity of iron. In the attraction of the ends there is nothing anomalous; for in sec. 3, the south end became a south pole, attracting therefore the north pole of the needle. But the indifference of the other end of the rod is more difficult to understand, because this shows the repulsion to be equal to the attraction ; and hence this end was bipolar in respect to the south pole. The case was the same with the other end of the rod; for this was indifferent in respect of the north pole, but attracted the south pole of the needle; and this end was therefore bipolar in respect of the north pole ; the attractive force of one being equilibrated by the repelling force of the other. Thrice happy the man who can clearly understand and explain these phenomena ! Doubtless the task will be extremely easy to those who are already well acquainted with the nature of bodies, and who are consequently enabled to decide even now upon the subject; although to ourselves it is one which is not intelligible at present, in consequence of the cloudiness of our reason and the obscurity of our mathematical ideas.

## 11 EXPERIMENT CXXXIV.

“ A long slender iron rod, such as was used in experiment cxxxi., was made red-hot and taken out of the fire with a pair of brass tongs ; it was then plunged into water in a position parallel to the horizon, and in the magnetic meridian. The north pole of the iron when cold immediately exhibited the force of a north pole, with which it attracted the south pole, of the needle ; the south end attracted the north pole of the needle. The attractive force of the rod, after being plunged into water, was much greater than when, as before, it had been left to cool on the floor. This has been noticed not only by myself, but by Gilbert,<sup>1</sup> Rohault,<sup>2</sup> Boyle,<sup>3</sup> and Wolff.<sup>4</sup> Reaumur, however, has lately called the observation into question in *Histoire de VAcadPm/ie Royale des Sciences*, 1723, *Mem.*, p. 81; affirming that he had often made the experiment but had never found any magnetic force immediately after the cooling of the iron. He therefore suspected that Gilbert and Rohault had not used sufficient caution in conducting the experiment, and that the iron, on being plunged into the water, had experienced some

<sup>1</sup> *De Magnete*, lib. i. cap. xiii., p. 31.—*Trs.*

<sup>2</sup> *Physica*, par. iii. cap. 8, § 38.—*Trs.*

<sup>3</sup> *Experimenta et Observationes Physical*, exper. vi. p. 10. Boyle, however, does not quite agree with Musschenbroek here. He says, “By the fore-mentioned way of refrigeration, I also found, that a disanimated loadstone (if I may so speak) may be restored to some degree of its attractive virtue ; for I try'd that a small loadstone, which, after its being made red hot in the fire, and cool'd perpendicularly upon the ground, was not able to take up a fragment of a needle ; being again heated, and not only cool'd upon the pole of a strong loadstone, but suffered to rest on it a while after, was soon grown vigorous enough to take up what formerly it could not move.” Again, in his *Philosophical Works Abridged* (vol. i. p. 503, § 11), it is said, “We took the same loadstone that was employed about the last experiment, and having again made it red-hot, in the fire, suffered it not to cool leisurely in the air, as before, but quenched it in a basin of cold water; intending thereby to make a double variation of the experiment; first, by cooling it hastily; and next, by cooling it in a fluid vastly more dense or ponderous than the air. The event of the trial was, that, upon the immersion of the red-hot stone, there fell off some flaky matter, as if it had been scales of iron ; and the stone, when cold, would not take up any filings of iron, as before it did ; so that it appeared to have lost much of the virtue it so lately had ; tho' it retained the power to move a well-poised needle if it were held near, on either side of the point of it.”—*Trs.*

<sup>4</sup> *Vernunfftige Gedancken*, § 382.—*Trs.*



degree of concussion; for he had observed that concussions produced by the hammer or otherwise, were apt to impregnate the iron with magnetic force. What are we then to say on this—  
 matter ? On which side lies the truth ? Experiment tells us that Gilbert, together with those who agree with him, and also that Reaumur, had the truth on their side. Here lies however the subtle cause of the difference. If we take a long and slender rod, such as we used in experiment cxxxi., there will always be found in it, immediately after being cooled in water, a very considerable magnetic force; while a portion of the same rod to the extent of one inch only, or a rod of a greater thickness and at the same time very short, after being cooled in water, never, acquires any magnetic force observable by the senses. Hence it is certain that Reaumur in his experiments used rods which were too short and thick; in which, therefore, no magnetic force was perceptible. Gilbert, Rohault, Boyle, and Wolff, tried the experiment with slender and long rods; and hence were led to think that a magnetic force was acquired by all heated iron after being cooled in water. From controversies of this kind we learn the care that is requisite in experiments, and attention to all the circumstances of the case ; that many of these experiments have been performed too hastily, and described more briefly than is desirable. We learn also how little we are at liberty to reason in physics, and from one kind of observation to deduce a general conclusion ; for this it is which in the foregoing instance has led all the learned into error. The observation which all had made in regard to the particular piece of iron was true, let the experiments have been made by whom they might; and yet the observation was not true as applied to every other piece of iron of whatever length or thickness.

“ I have since found the same kind of remark in the *Philosophical Transactions*, vol. xviii. p. 257, by an anonymous writer,<sup>1</sup> who, to the observation of Gilbert, adds the following reflections. ‘ But this holds but in some cases ; *sc.* if the rod is short, you cannot make a fixed pole that way. Take a round wire whose

<sup>1</sup> The writer signs himself “ J. C.”—*Trs.*

diameter is  $\frac{1}{2}$  inch, and length 10 inches ; you cannot produce a fixed pole by ignition ; but if this wire were longer, as suppose 30 inches long, or never so much longer, 'tis capable of a fixed pole by ignition. Again, take a round rod 30 inches long and 1 inch diameter, this rod is not capable of a fixed pole at that length ' (pp. 258-259). He next adds, that <sup>4</sup> there is no rod ever so short, but which if you make it sufficiently thin, is capable of a fixed pole. . . . The *terminus*, or necessary length for every thickness increases more than you would be apt to think' (p. 259). I wish this accurate writer had given his experiments ; but he seems to have purposely omitted them as useless ; although in my opinion they would have been of the greatest service.

“ EXPERIMENT CXXXV.

“ The slender iron rod, which I had used in experiment lxxxi. I again made red-hot, and took it out of the fire with brass tongs, holding it horizontally; so that it should be always in the same terrestrial meridian. That half of the rod which pointed to the south I plunged into water; keeping it almost in a horizontal position; after which the south end of the rod and the north attracted the north pole of the needle.

“ This rod was again made red-hot; the half of it which was pointed to the north, was plunged into water, the other half remaining out of the water. In this case the north end of the rod repelled the north pole of the needle, and attracted the south pole. These phenomena which will be more clearly understood after the explanation of our next experiment.

“ EXPERIMENT CXXXVI.

“ A slender oblong iron rod was made red-hot, and taken out of the fire with tongs, with which it was held perpendicularly to the horizon. The lower end of the iron, even when red, strongly attracted the south pole of the needle, and repelled the north; but the higher end attracted the north pole of the needle and repelled the south.

“ Thus the heated iron became immediately endowed with a

magnetic force, when held in this vertical position, and as quickly as if it had been rubbed with a magnet.

“2. This rod was left in the same vertical position for the space of an hour, and it then showed the same influence upon the needle as before, with the exception that it did not so strongly attract it, when cold, as when it was heated.

“ 3. The same rod was again made red-hot and plunged perpendicularly and entirely into water; in this case its lower end became a north pole; for it strongly attracted the south pole of the needle. A repetition, however, of these heatings and coolings did not appear to me to increase the attractive force of the rod.

“ 4. Finally, the same rod when heated was plunged perpendicularly into water up to half its length ; the lower end on being cooled, became a north pole ; and the higher end, immediately after cooling, attracted equally the north and the south poles.

“5. In the next place there was placed perpendicularly upon the ground a heated rod, 5 inches long, with a section one inch square. After the lapse of an hour, when it had cooled, the lower end attracted the north pole of the needle, the upper end also did the same. In this short iron rod, therefore, the directive magnetic force is not accumulated within so brief a time as in more slender rods. Nor indeed is it accumulated in iron of this thickness suddenly, even though it be plunged into water.

“We may, however, observe with regard to all iron, even when very thick, indeed, with regard to those pieces which could not be impregnated by the magnet with magnetic force by reason of their size, that when placed in a position perpendicular to the horizon, they become spontaneously endowed with a magnetic force; thick and short pieces not till after some length of time ; thick and long pieces more speedily. But the long and slender pieces did not require a minute. For if we take a rod 6 feet long, and I of an inch in diameter, and hold it perpendicularly to the horizon ; then with its lower end it will attract the south pole of the needle and repel the north ; and with its upper end it will attract the north pole of the needle and repel the south.

Now immediately invert the rod, and within a minute you will perceive that the lower end will attract the south pole of the needle which it had before repelled; so that in a rod of this kind, the poles become very rapidly changed. The same phenomena may be observed in a shorter but much more slender rod. Some of these phenomena Grimaldus had formerly noticed in his *Physico-Mathesis de Lumine, Coloribus, et Iride*, prop. vi. sec. 51; as also Boyle,<sup>1</sup> and also Poliniere in his *Experiences Physique*, Paris, 1728, p. 286 ; and more recently Reaumur, in *Histoire de VAcademic Royale des Sciences*, 1723, *Mem.*, p. 81. We must also add, that sometimes there are steel plates which, when heated and plunged into water perpendicularly to the horizon, acquire fixed poles incapable of change, turn them in whatever direction we may. There are also others which preserve their poles fixed, but when inverted do not exert so strongly the force of the same pole as before ; and they show at last rather an inclination of the same pole. There are others which, after being turned, become indifferent; so that when brought near the mariner's needle they direct it eastwards and westwards ; and thus, as it were, maintain it in equilibrium. These phenomena, however, are seen only in slender steel plates; for in thicker pieces of iron only those phenomena are observed which I have above adduced. The principal part of this observation may be seen in the *Philosophical Transactions*, vol. xx. p. 417.

“ If pieces of iron remain for some time fixed, as, for instance, the iron lattice-work of windows, which in old houses has lasted for hundreds of years, they acquire a very considerable power of acting upon the needle, even at a distance of 4 ells and more ; as Cabaeus observed at Mantua (*Philosophia Magnetica*, lib. i. cap. xvii. p. 62).

“ From these experiments it is evident, that a needle may always be obtained which shall direct its ends toward the north and south part of the heavens, although not rubbed against a magnet, provided that for some time it stands vertically erect,

<sup>1</sup> *Philosophical Works Abridged*, vol. i. p. 498.—Ed.

or when heated, is immersed in a perpendicular position, into water.

“ If a longer rod is chosen for these experiments, the point-attracting the north pole of the needle will be always more distant from the extremity of the iron than the point which affects the south pole of the needle ; as was formerly observed in the *Philosophical Transactions*, vol. xviii. p. 257, and as Reaumur also has recently stated.<sup>1</sup>

“It is moreover a remarkable fact, that heated iron, placed perpendicularly to the horizon, becomes imbued with magnetic force ; although the magnet itself when made red-hot and afterwards placed in a like perpendicular position, while cooling, neither retains nor acquires any virtue. With a view to ascertain this fact, Boyle took some oblong magnets, which he made red-hot and then allowed them to cool, after placing them in a north and south direction, and either in a horizontal, perpendicular, or other oblique position; but he could never observe any directive or attractive force remaining in them. See his remarks concerning magnets, in his *Philosophical SVorks Abridged*, vol. i. p. 499.

#### “ EXPERIMENT CXXXVII.

“ The same extremity of the needle is attracted in different ways, in different places of the earth, by the same ends of the iron rod, when held perpendicularly to the horizon and opposite to the needle.

“ This is evident from the observations taken by a navigator, inserted in the *Philosophical Transactions*, vol. xv. p. 1213 ; and which I think ought not to be omitted, as I have never met with any other person who has made similar ones. They were written in the year 1684, by a navigator who crossed the equator.

“ 1. From England as far as  $10^{\circ}$  north latitude, the north part of the needle attracted the upper end of an iron rod. The south part of the needle attracted the lower end of the rod.

“2. At a north latitude of  $9^{\circ} 42'$ , and at a longitude west-

<sup>1</sup> See p. 532.—*Trs.*

ward of Lizard, the south end of the needle strongly attracted the lower end of the rod; but the north end of the needle did not attract the upper part of the rod so strongly as in the case preceding.

“3. At a north latitude of  $4^{\circ} 33'$ , and at a longitude of  $5^{\circ} 18'$  westward of Lizard, the north part of the needle began to decline from the upper part of the rod, and the south part of the needle more strongly inclined toward the lower part of the rod.

“4. At a latitude of  $0^{\circ} 52'$  south, and at a longitude of  $11^{\circ} 52'$  westward of Lizard, the north end of the needle was not attracted by the upper part of the rod, nor was it sought by the lower part of the latter; the south end of the needle however inclined to the lower part of the rod, although not so strongly.

“ 5. At a latitude of  $5^{\circ} 17'$  south, and at a longitude of  $15^{\circ} 9'$  westward of Lizard, the south end of the needle was turned to the lower part of the rod; nevertheless it did not seek the upper part of it, which also was not attracted by the north end of the needle. But when the rod was placed horizontally in a line parallel to the terrestrial meridian, then the north end of the needle was turned toward the south end of the rod.

“6. At a latitude of  $8^{\circ} 17'$  south, and at a longitude of  $17^{\circ} 35'$  westward of Lizard, the north end of the needle did not seek the upper part of the rod, but rather shunned it; the south end of the needle, however, in some measure sought the lower end of the rod, and changed its true position about two points. The rod was next placed over the needle, so that the upper part of the rod faced the south pole of the heavens, and the lower part the south pole ; in which case the north part of the needle sought the lowest part of the rod, and followed its motion ; but when the rod was placed horizontally, the phenomena were the same as above.

“ 7. At a latitude of  $15^{\circ}$  south, and at a longitude of  $20^{\circ}$  westward of Lizard, the south end of the needle began to

seek the upper part of the iron rod, and the north end of the needle attracted the lowest part of the rod, which it followed ; but when the rod was placed horizontally, then the north pole of the needle sought the south part of the rod.

“8. At a latitude of  $20^{\circ} 20'$  south, and at a longitude of  $19^{\circ} 20'$  westward of Lizard, the south end of the needle sought the upper part of the rod, and the north end turned strongly toward the lower part.

“9. The same results took place at a latitude of  $29^{\circ} 25'$  south, and at a longitude of  $13^{\circ} 10'$  westward of Lizard.

“ These results we might have determined a priori, after it was known that the north end of the needle, in the northern hemisphere of the earth, inclined downward toward the horizon ; that in the southern hemisphere of the earth, the south end inclined downward, and the north upward; because the north pole of the terrestrial magnet prevails in the northern part of the earth, and attracts to itself the north end of the needle; but in the southern hemisphere, the south pole of the same magnet prevails; whence it determines the south end of the needle towards itself. Since, therefore, by experiment cxxxvi., the lower end of the rod when held perpendicularly in this region, attracts the south pole of the needle; it is impressed by the terrestrial magnet with the force of a north pole;—and for this reason, that the lower part of the rod is nearest to the north pole, and will, therefore, receive the force of this pole as long as it is nearer to this than to the south pole of the magnet; but as soon as the lower end of the rod approaches nearer the south pole of the terrestrial magnet, it will receive the force of the latter, which is plainly opposite to the former; and, therefore, the lower end of the rod will attract the north pole of the needle. But in that part of the earth in which the force of the poles of the terrestrial magnet has become equal, the lower end of the rod will not be endowed with any force ; and it is for this reason that the lower end of the rod was observed to be impregnated with the force of the north pole of the terrestrial magnet in the northern region of the earth, as far as a south latitude of  $8^{\circ} 17'$ ; because the force

of this magnetic pole extended itself to this distance. Beyond, however, a south latitude of  $15^\circ$ , the force of the south pole of the magnet began to predominate; and, communicating its force to the lowest extremity of the rod, caused the latter to attract the north pole of the needle; the force of the terrestrial magnetic poles was commonly in equilibrium from a south latitude of  $0^\circ 52'$  to  $8^\circ 17'$ ; hence each extremity of the rod was endowed with scarcely any magnetic force. We have seen, in the inclinations observed by Noel,<sup>1</sup> that the inclination of the needle steadily diminishes from the north latitude of  $38^\circ 40'$  to the south latitude of  $6^\circ 30'$ ; a sign that the force of the north pole of the terrestrial magnet extends itself hither; but on receding hence more from the equator to the south, the inclination of the needle was inverted, and the end which faced the horizon in the northern part of the earth, was now directed upwards, the pole of the south magnet predominating; the force of which continued to increase until, in the latitude of  $35^\circ 25'$ , it reached its maximum and erected the needle perpendicularly to the horizon; therefore also in the present observation it was rightly noticed that at a south latitude of  $20^\circ$ , and farther to  $29^\circ$ , the lower part of the rod strongly attracted the north end of the needle; in fact, the force was observed to be the stronger according as the experiment was taken in a greater southern latitude,  $35^\circ$ , and in the same longitude as that of Madagascar.

#### “EXPERIMENT CXXXVIII.

“An iron rod was placed upon an anvil, so as to be in a position parallel to the terrestrial meridian. The end facing the north, when struck with a hammer, became a north pole; the south end, when struck with a hammer, became a south pole. This experiment, however, succeeds only with rods of a certain length and thickness, and not with all. For if a rod were too thick in proportion to its length, then, although both ends were

<sup>1</sup> The observations of Noel are cited by Musschenbroek on p. 208 of his work, that part of it which Swedenborg does not quote. See also Noel's *Observations Mathematicæ et Physicæ in India et China factæ*. Prague, 1710, p. 121.—Trs.



struck with a hammer, the directive force of the poles would be observed to be nil, unless the end were so thin that the slenderness of the rod maintained a certain proportion to its length? 'All that we have said concerning the effect produced by a hammer, is to be understood as produced by a file passed over the iron, or by rubbing the iron upon any hard body, or by cutting it with a saw; provided the iron be long and slender. The stronger the force with which the forementioned instruments come into contact with the iron, the greater is the degree of magnetism induced ; and yet the magnetism never increases to such a degree as may be. communicated to the iron by a magnet of moderate power. As in hammering the rod upon an anvil, we induce upon one end a north pole, and upon the other a south pole in this part of the world ; so we ought to pursue the method which is pointed out by the inclination of the needle. The south part of the iron upon the anvil should be considerably more elevated ; the north part more depressed; in this manner a rod when hammered will always have two poles at its ends. But if the iron be held upon the anvil in a different manner, sometimes we shall perceive at each end a north pole. Similar remarks may be observed in the *Philosophical Transactions*, vol. xviii. p. 257.

“ EXPERIMENT CXXXIX.

“ Let a plate of very soft iron be held between the jaws of a pair of pincers, so as to project beyond them ; let it next be forcibly bent to the right and left, until it is broken. The fragment will then attract iron filings, just as if the plates had been impregnated with the force of a weak magnet.

“ Reaumur conducted this experiment with large pieces of iron; with wire made of the best iron, and also of soft and fragile iron; with tempered steel, and with steel not tempered. Other things being equal, the softer the iron that is broken, the more fibrous it is and the more bendings are required to break it, the greater is the acquired force. Fragile iron, very soon broken, is impregnated with a less degree of force ; and steel that is well tempered with a still less force ; with regard to the latter, the

softer or harder it is, the more strongly or weakly it attracts. \* In general all iron broken by being bent becomes magnetic ; this, however, sometimes lasts only for a day. The author also records that the attractive force is not sensible if the iron has only the thickness of a needle ; and that the force is not increased in the ratio of the thickness of the plates, but is greatest in iron of the thickness of the little finger.<sup>1</sup> In these experiments we see a definite length of iron is required. For if we bend and break in the middle a piece of iron a foot long, then both fragments will manifest magnetic force; but when the iron is so broken that either fragment is not more than a digit in length, then it will not attract the filings, however fine ; while the other and longest fragment will attract them with great force.

“ In these experiments the broken end alone acquires magnetic force ; the other extremities remaining such as they were before the experiment.

#### “ EXPERIMENT CXL.

“For many beautiful experiments with iron we are indebted to the insight of Reaumur, and among others for the following. If an iron rod about the thickness of the little finger, and 2| feet long, is held by a pair of pincers, and if by frequent bending it be broken 5 digits from its end, then each surface of the fracture has only so much magnetic force as to be able to lift a small nail.

“ If the longer fragment, inserted into the jaws of the pincers, be frequently bent at 1| inches from the fracture, yet so as not to break it, then the surface of the former fracture has acquired a greater force of attraction. Afterwards, if we bend the iron in other places, but always nearer to the middle, we find the magnetic forces increased. In eight places bent in this manner, the former fracture had acquired so great a force as to be able to lift four nails. On continuing the bending from the middle of the iron to the opposite end, and as often examining the force of each end, we find the magnetic force of the fracture decreases ; while that of the other end at the same time increases; until after

<sup>1</sup> *Histoire de VAcademic Iloyale des Sciences, 1723, Mem., p. 81.—Trs.*

frequent bending in various places of the iron, the end acquires a power capable of lifting four nails, while the surface of the fracture is then capable of carrying only particles of filings'.

“ EXPERIMENT CXXI.

“ If a piece of iron wire is frequently bent in the middle, its two ends do not acquire any manifest force. Let us conceive divisions to be marked from the middle of the iron toward each extremity, at equal distances one from the other; and let the iron be bent at the two divisions, one at each side of the middle, and equally distant from it, then both ends of the iron will acquire a magnetic force; but weaker than if the bending\* had taken place in one part at the middle ; nay, so weak will be the force of each end, that it will not equal  $\frac{1}{2}$  or  $\frac{1}{3}$  of that which it had, when the bendings were made at the half division of the iron. ‘

“ EXPERIMENT CXXII.

“If by various bendings iron wire is endowed at either of its ends with a considerable attractive force ; and if it next is bent in other places also between the same end and the middle dividing mark, then the attractive force of the end, so far from being increased, will be rather destroyed; just as I have before observed, that the force, pertaining to wire rubbed against a magnet and then frequently bent, is also destroyed.

“ EXPERIMENT CXXIII.

“We shall here notice a paradox connected with iron ; which, if hammered in different ways, differently exhibits a magnetic force. If a thick iron plate AG-MB, be hammered upon an anvil with the broad and plane part of the hammer C, it will acquire no attractive force; if, however, it be hammered with the narrower part D, proceeding from E to B, the end A will acquire a certain force, although feeble ; but nowhere else will any force be observable, or in any part around the hammered places. Next let the strokes of the hammer be directed along the middle of the

length FP, taking care that the parts FEBP are not hammered, or FLMP, with the exception of the small rectilinear part FP ;

Fig. 83.

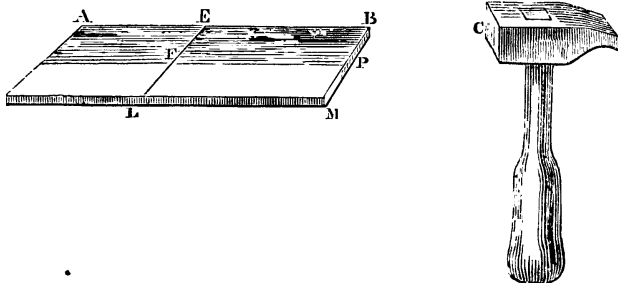

then both the angles at A and G will be endued with a magnetic force ; but not the middle part between the points A and G.

“ EXPERIMENT CXLIV.

“ As soon as any iron tool cuts a piece of cold iron, it acquires an attractive force ; if it cuts or abrades red-hot iron, it loses none of whatever force it may have had before. If a wedge of steel, possessing magnetic force, be struck by a mallet and made to cut red-hot iron, then will the wedge lose its magnetic force.

“ EXPERIMENT CXLV.

“ Iron bodies which end in a point, acquire a greater magnetic force than those which end with a broad or plane surface. It is for this reason that a drill attracts with its point more than a knife ; the shorter the drill is, the less the force with which it is endowed. For Reaumur has observed that a drill 1 inch long and 9 lines diameter, although it easily perforated iron, yet would attract only a few filings; while on the other hand, a drill 3 or 4 inches long, and a line or 1| lines in diameter, attracted small nails. Drills however appear to experience an increase of their attractive forces in the act of revolving, while perforating iron,

copper, or stone ; as is rightly noticed by Hooke, in *Philosophical Experiments and Observations*, Published by Derham, p. 128; by Ballard, in the *Philosophical Transactions*, vol. xx. pp. 417-420;— by Reaumur, in *Histoire de VAcademie Royale des Sciences*, 1723, *Mem.*, p. 81. Hence it is no wonder that filings which have come in contact with the drill, and which have been scooped out of a hole, possess a magnetic force derived from the drill.

#### “EXPERIMENT CXLVI.

“ All new tools of tempered steel, clenched by pincers, and strongly filed until they begin to grow hot, possess a great attractive force, and even greater than when cool.

“ Every piece of steel rubbed strongly upon the ground till it acquires a considerable degree of heat, manifests attractive force clearly; which it nevertheless loses as , soon as it grows cold. This was known to Boyle, and was described by him in *Mechanical Production of Magnetism*;<sup>1</sup> and by Ballard, in the *Philosophical Transactions*, vol. xx. pp. 417-420; who adds, that the poles of the iron are changed by attraction ; for he rubbed a knife upon a magnet, and the point of the knife became a south pole; but when the knife was strongly rubbed against hard and dry wood, so as to produce considerable heat, the point lost the force of a south pole, and changed into a north pole; a circumstance which he found continually recurring on frequently repeating the experiment. This, however, we should observe, takes place only in a thin knife; for a thicker one does not lose by rubbing the poles which the magnet had impressed, the parts not having experienced sufficient concussion.

“ This subject, however, may be amplified, and deserves to be so, with additional observations concerning the attractive and directive forces of iron; for they may occasionally afford considerable light in tracing out the cause of magnetism. I have already, however, been sufficiently long ; for it was not my intention to write a volume, but only a brief dissertation. The observations which I have here recorded are only the first-fruits

<sup>1</sup> See Boyle's *Philosophical J Po rks Abridged*, vol. i. p. 497.—Trs.

of enquiry, and such as have been discovered or demonstrated in our own age : to which I will add, in the way of an appendix, another which I have often observed confirming the existence of a universal directive force. The extremely small scales of iron, which, when iron is hammered, fall from the anvil in the blacksmiths' shops, all attract one another, and take a direction north or south in a line according with the magnetic meridian ; provided the floor on which the anvil stands is level and made of wood.

<sup>44</sup> From these experiments we gather, that the force of the magnet enclosed within the earth is quite universal; that it extends itself throughout every quarter of the globe ; that it acts upon all iron, and imparts to it a direction in accordance with what we have above said, namely, that iron is attracted and governed by the magnet.

<sup>44</sup> But how this great magnet has acquired its virtue can by no means be deduced from any observations hitherto recorded. Wherefore other experiments must be undertaken by posterity, in order to put us in possession of our wishes, and to solve a problem hitherto so intricate and abstruse. The true method will be for philosophers to become observers, and subject the magnet to various experiments, apart from any speculations or making of hypotheses of their own ; for these, assuming as they do only deceitful smiles, retard all further experiment and all progress of science, because they affect to be the solution of the problem. These hypotheses, however numerous, have hitherto served no useful purpose; have obscured the intellect by their noxious fumes; and have only compelled succeeding and more prudent enquirers to institute fresh examinations. Nor indeed upon this subject does the opinion of the wise Fontenelle differ from our own; who, in *Histoire de l'Académie Royale des Sciences*, 1723, p. 36, after a beautiful explanation of the hypotheses and experiments of Reaumur, adds, that philosophy would have been best contented with his labours, had he only discovered all the phenomena of the magnet. For what is the use of hypotheses, however subtle and ingenious, if they cannot explain

or geometrically demonstrate phenomena. When the phenomena are discovered, the cause will be no longer hidden; and when the cause is found and properly understood, all the phenomena will be mathematically proved, and the doctrine of magnetism may then take its place among the parts of mixed mathematics. In the meantime, one thing may be considered as demonstrated ; namely, that this stone, endowed with such wonderful and widely diffused virtues which have never yet been comprehended by the most sagacious mind, cannot consist of some fortuitous collection of mere atoms, nor have originated from a cause endowed with less virtues, but from One far more excellent—the fountain-head and origin of all things, of all bodies, and of all forces, whose Infinite Wisdom produced nothing but what breathes of wisdom; and whose stupendous works it is given to finite and puny mortals to behold, to admire, and to venerate ; in order that from these it may be the more evident, that there is a God who possesses attributes, every one of which is infinite ; and who has created this stone, as He has all other things, in unspeakable profusion ; and given it to mortals, in order that by its aid the mariner may, without uncertainty, navigate the vast oceans leading to the remotest countries, and carry to and from the most distant regions the vegetable produce and mineral riches of the earth; so that all the different races of mankind may become acquainted with the nature of its treasures, and apply them universally to use ” (op. cit. pp. 253-270).

## APPENDIX.

SUCH are the experiments adduced by that very able philosopher, Pieter van Musschenbroek, in his *Physicce Experimentales et Geometricce*; experiments, the reasons and causes of which, as derived a priori and from first principles concerning the magnetic forces, it has been my wish to subject to examination, and from this we may see that magnetism consists only in the regular arrangement of the parts; through the medium of which a perfectly regular sphere may be formed both around the magnet and around the iron. To each of these experiments I might have added my own remarks, and thus have rendered the causes still more evident; but this was superfluous. Indeed what proof can be plainer than the one derived from iron filings sprinkled round the magnet, which in a continuous line follow the course of the magnetism, and dispose themselves into the same situation and path as those of the smallest parts in the iron; and if we could see the latter with the help of lenses or with the naked eye, they would be seen to be arranged in a similar manner. In filings, therefore, we may see the effigy of the parts in the iron which are brought into a regular order at the will of the magnet, and hence endued with magnetism. If we could artificially combine steel dust into a solid mass, and move the magnet over it, we should have ocular proof that every atom took up that position which the smaller parts of iron assume when rubbed; that is to say, a regular arrangement. If this arrangement of the parts in the iron is disturbed either by too frequent bendings, or by too hard blows, or by fire, then the iron immediately divests itself of its magnetism and assumes its original character; as is evident from many of the experiments of Musschenbroek, chapter xi. From these also it follows that the



emanations themselves consist of like and most minute parts of the iron, which, by means of the regular arrangement of similar parts within the limits of the body itself, and in consequence of—<sup>1</sup>the very attenuated element, produce a regular sphere around the magnet. This sphere could not be produced without a regular arrangement and connection of the parts on all sides with the magnetic or iron body. Nor am I aware that there either is, or can be, any proof which does not attest and establish the fact that the active forces themselves of the magnet consist in what we have referred to above.









# RETURN CIRCULATION DEPARTMENT TO—202 Main Library

LOAN PERIOD 1 <b>HOME USE</b>	2	3
4	5	6

ALL BOOKS MAY BE RECALLED AFTER 7 DAYS

RENEWALS AND RECHARGES MAY BE MADE 4 DAYS PRIOR TO DUE DATE  
LOAN PERIODS ARE 1-MONTH, 3-MONTHS, AND 1-YEAR  
RENEWALS; CALL <415> 642-3405

## DUE AS STAMPED BELOW

<b>MAR 10 1990</b>		
<b>APR 4 1990</b>		
<b>MAY 15 1990</b>		
<b>REC CIRC MAY 17 1990</b>		

UNIVERSITY OF CALIFORNIA, BERKELEY  
FORM NO. DD6, 60m, 1/83 BERKELEY, CA 94720

U.C. BERKELEY LIBRARIES

**mnunm11**

C02270°1355

